



Technology Solutions

TEK-DP 1610F

Restriction Orifice



FLOW

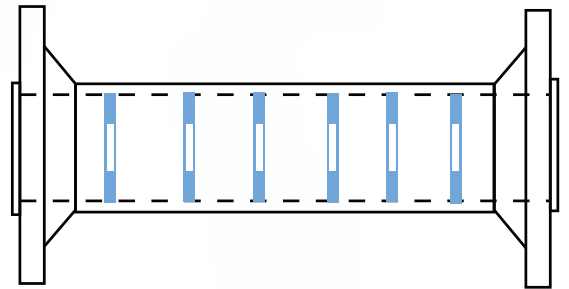
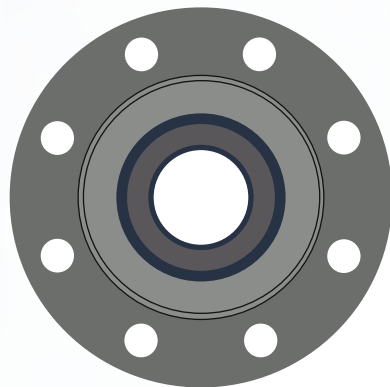
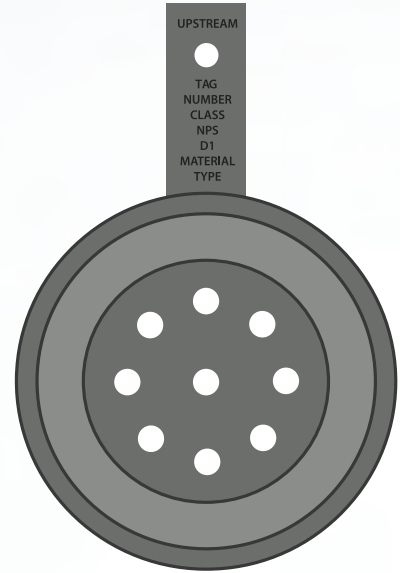
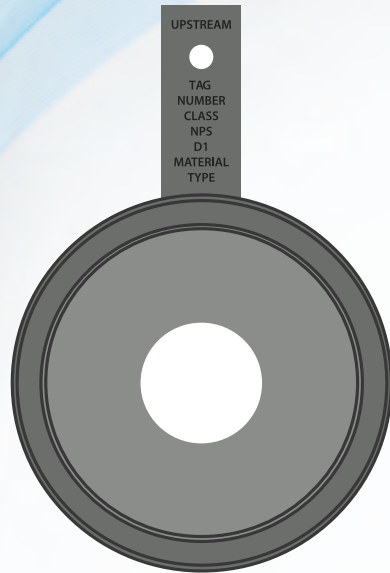

Introduction

The 1610F Restriction Orifice (RO) is utilized to achieve controlled or restricted process fluid flow. It can be designed as a single or multiple orifice configuration to provide a defined restriction to the process flow and create a calculated pressure drop from the upstream to the downstream side of the device. The permanent pressure loss generated by the RO is intentionally sized to control the flow rate and achieve the desired final pressure at the outlet side of the unit. This range can vary from 1000 PSIG to 5 PSIG for both liquids and gases.

When selecting or purchasing a Restriction Orifice from Tek-Trol, it is recommended that the Tek DPro Engineering Staff be involved. This is because the pressure drop and flow calculations are based on the specific process conditions of the client. It is essential to install the device in the designated location and operate it within the specified pressure and temperature ranges for which it has been designed.

Operation

Restriction Orifice plates and designs follow Bernoulli's principle with additional calculation software algorithms devised by Tek-DPro to calculate the outlet pressure required based on process conditions precisely.

The multi-stage unit is supplied to US national welding standards and pressure vessel design with ASME-based hydro testing and radiography where required. Other international welding / NDT standards are also available. Also, a document package should include these documents; please call after-sales service if these documents are not or have not been supplied.

Features

- Proven technology
- Prevent critical flow or cavitation issues.
- Reduce site restrictions and noise levels.
- Reduction in line pressure.
- Control flow rates by restricting flow, regardless of downstream conditions design considerations.
- Prevent critical flow.
- Removal of cavitation.
- Reduce noise levels.
- Designs available to accommodate site restrictions and noise limitations.
- Prevent critical flow or cavitation issues

Typical Application

- Installed downstream blow-down valves systems to ensure a controlled flow rate in the blowdown piping or blowdown header.
- They are installed in minimum flow bypass lines around centrifugal pumps.
- Can be installed in Wellhead Separator applications – (install details in this document).
- Restriction Orifice units are sometimes used to restrict excess flow in a ruptures case.
- Injection, cooling (using Joule Thompson effect), and fluid flushing systems.
- Sampling mixer.
- The steam let down.
- Use as a simple static mixer.

- N2 purge to provide constant gas seal parameters.
- Flow Control improvement

Specifications

R.O. Plate Types	<ul style="list-style-type: none"> • Square Edge Concentric- Single or multi element units. • Eccentric , Segmental – Single or Multi-Element • DP1610 – Multi-Element Device, Flanged & Pressure Tested. • Single -Element Plate Only (Client Installation)
Plate Material	<ul style="list-style-type: none"> • 304SS, 304L SS, 316SS, 316L SS • Ni,Cr,Mo,Alloy Steel (A182 F11 to 91) • Monel, Hastelloy, Inconel (on request)
Pressure Rating	Available in accordance with National and International standards
Plate Thickness	Calculated taking into consideration the required process pressure reductions, flow, and the pipe size and liquid or gas process details according to clients' piping requirements and standards.
Mounting	Flanged or clients piping requirements
Nominal Pipe Diameters	1 inch to 24 inches(25-600mm) (Note: Other diameters on request)
Support Pipe	Full NDT with Dye Penetrant, Radiography & Hydrotest (Flanged or butt weld)
Flange Rating	ANSI 150, 300, 600, 900, 1500, 2500RF/RTJ as required.

Types of Restriction Orifice

The 1610 F Restriction orifices can be classified into four different types :

Single Stage Restriction Orifice

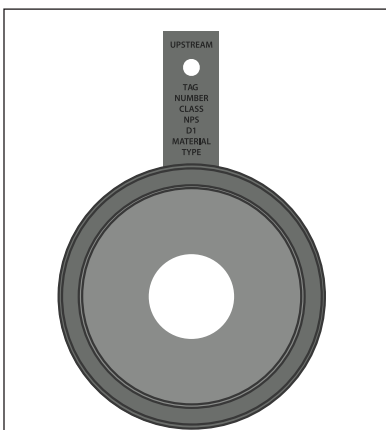

The first type of Restriction Orifice is the single-stage restriction orifice which provides the simplest pressure drop. It is usually a plate with a single orifice bore of the required size/beta ratio for an intended pressure loss.

It is usually machined with a square-edged plate edge to resist the maximum DP with sufficient headroom.

Installation of Single stage Restriction is shown below

Multi-hole Single Stage Restriction Orifice

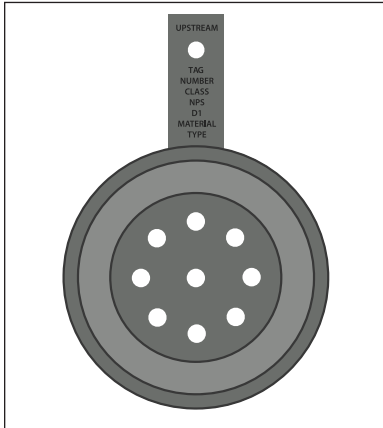

The second type of Restriction Orifice is a multiple-hole single-stage restriction device. The extra holes help to reduce fluidic noise and resonance generated due to a high velocity across the reduction. This type of restriction orifice can have the same area ratio as a single-hole unit and offer the same pressure reduction parameters. However, the multiple holes help to distribute the flow streams to reduce the overall noise.

Usually, when a high-velocity flow at the RO inlet is distributed through multiple-hole designs, the overall noise value is reduced. This type of Restriction orifice is commonly used to help minimize cavitation problems since the flow distribution across several holes is known to improve cavitation factors, which can reduce overall noise levels.

Restriction Orifice Typical Separator Installation (Multistage Unit)

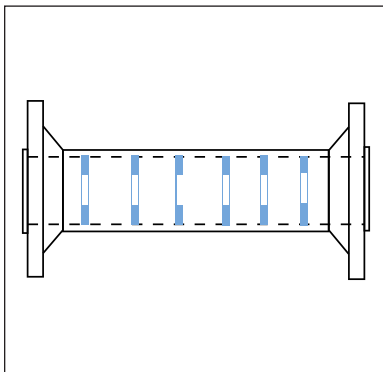

The third type, known as a Multi-Stage restriction Orifice, is a multi-element pressure reduction/flow control device. This restriction unit is designed with either single-hole multiple orifice plates or multi-hole designs with different hole sizes. It allows for effective control of pressure and flow rates, preventing cavitation in a pressure reduction system or reducing the flow to manageable values.

The below figure shows one typical pressure reduction application as applied to a separator outlet in the oil and gas industry as currently being used by Oil and Gas midstream operators.

Installation

The design and sizing of the Tek DPro 1610 F restriction orifice has been reviewed by a specialist for stress and noise related evaluations plus applicability for use in your application and confirmed at the quotation stage supply.

Tek-DPro Restriction Orifice (R.O) Systems are designed with a substantial plate thickness to withstand the high differential pressures applied, manufactured with a bore in the center and either inserted between two flanges of a pipe (single unit), or in a multiple plate / stage device.

The following installation parameters should be confirmed before installation:

1. Inspect the shipping container that the R.O. unit has been supplied in for any damage, if so, report the incident back to after sales service with the serial number and also, if possible, a photograph. Inspect the R.O. unit itself for damage if any has occurred and also confirm back to after sales service.
2. Confirm that the data sheet supplied with the unit meets the pressure and temperature parameters for the application and that the serial / tag numbers are intact and meets the technical specification data sheet or purchase order details.
3. Inspect the flanges where the restriction orifice plate (single) is to be installed for scratches / damage and make sure that the correct gaskets are used for the application (client responsibility).

4. Make sure the installation is per local regulations for pressure containment devices i.e., pressure ratings are correct for the required pressure and temperature and the steel type is also confirmed for the pipeline and orifice unit (single plate type).
5. For multi-stage units which are supplied in a housing consisting of a pipe and flanged assembly based on the client's originally supplied data sheet parameters, inspect the flanges for scratches, review the hydrotest certificate to confirm the operating pressure meets the install location pressure and temperature requirements.
6. Install the multistage restriction orifice unit between the users flanges without applying a bend force to the housing or use the R.O. to align the receiving flanged pipes. Support the installation piping with a stanchion if possible either side of a multi-element R.O.
7. All multi element /stage units are designed to withstand the high restriction forces applied to the stated pressure and pressure reduction limits, Note: Do not use / install the unit in any location that it has not been specified or designed for. This could cause a catastrophic failure of the elements and at worst case a support pipe housing failure.

Restriction Orifice Typical Separator Installation (multistage unit)

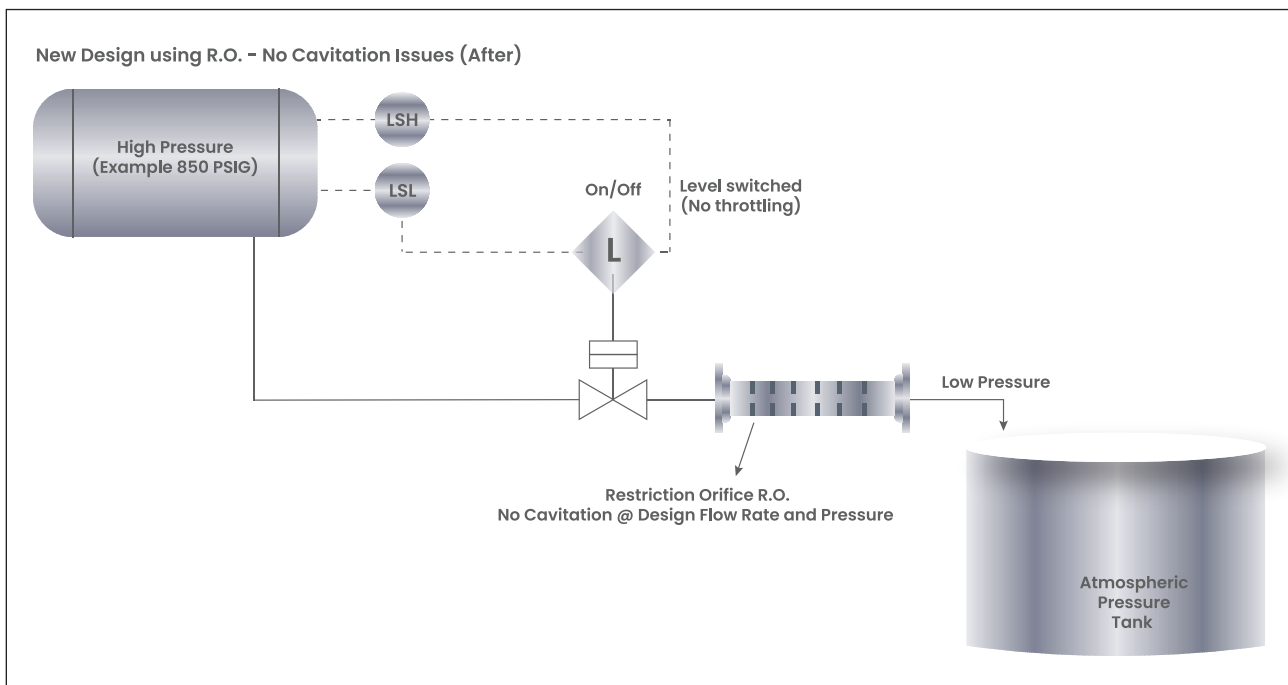
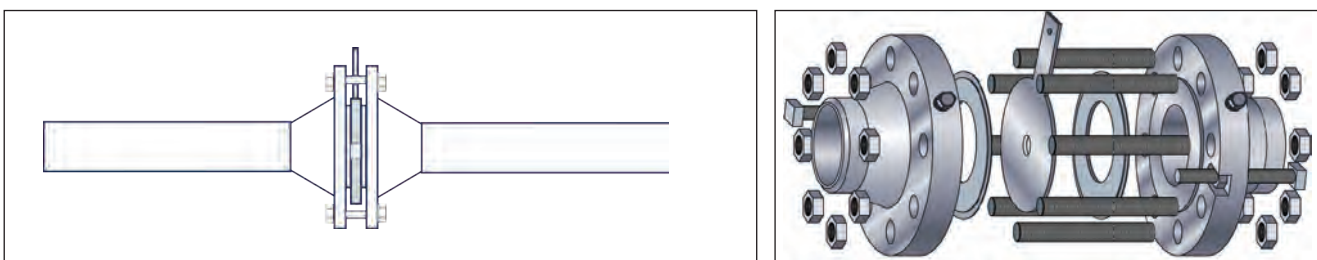

Figure 1. New R.O. System Installed

The above image shows a multi-element restriction orifice installed offering both a pressure and flow restriction to client's requirements without cavitation, allowing the system to be fully running or shut down based on the clients upper and lower-level limits. From say 1440 PSIG to 5 PSIG as calculated by Tek-DPro. Engineering team for this application

Single stage Installations



Customer Service & Support



TEK-TROL LLC reserves the right to change the designs and/or materials of its products without notice. The contents of this publication are the property of TEK-TROL LLC and cannot be reproduced by any other party without written permission. All rights reserved. Copyright © 2022 TEK-TROL LLC
TEK-TROL LLC
DOC # TEK/TIP/SCA1/09923/16/10/7/00



www.tek-trol.com

Tek-Trol LLC

796 Tek Drive Crystal Lake, IL 60014,
USA
Sales: +1 847-857-6076

Tek-DPro Flow Solutions

PO Box 121 Windsor, Colorado 80550,
USA
Sales: +1 847-857-6076

Tek-Trol Solutions BV

Florijnstraat 18, 4879 AH Etten-Leur,
Netherlands
Sales: +31 76-2031908

Tek-Trol Middle East FZE

SAIF Zone, Y1-067, PO BOX No.
21125, Sharjah, UAE
Sales: +971-6526-8344

Support: +1 847-857-6076

Email: tektrol@tek-trol.com

www.tek-trol.com

Tek-Trol is a fully owned subsidiary of TEKMATON LLC. We offer our customers a comprehensive range of products and solutions for process, power and oil & gas industries. Tek-Trol provides process measurement and control products for Flow, Level, Temperature & Pressure measurement, Control valves & Analyzer systems. We are present in 15 locations globally and are known for our knowledge, innovative solutions, reliable products and global presence.