



Technology Solutions

TEK-FLEX 4100A

Explosion-Proof Guided Wave Radar Level Transmitter

Instruction Manual

Document Number: IM-4100A



Table of Contents

1	Safety Instructions	3
1.1	Intended Use	3
1.2	Certifications	3
1.3	Safety Instructions from the Manufacturer	3
1.3.1	Disclaimer	3
1.3.2	Product Liability and Warranty	3
1.3.3	Information Concerning the Documentation	3
1.4	Safety Precautions	3
1.5	Packaging, Transportation and Storage	4
1.5.1	Packaging	4
1.5.2	Transportation	4
1.5.3	Storage	4
1.5.4	Nameplate	5
2	Product Description	5
2.1	Introduction	5
2.2	Measuring Principle	5
2.3	Components of Tek-Flex 4100A	7
2.4	Specifications	7
2.5	Dimensional Drawings	8
2.5.1	Signal converter and probe electronics options	8
2.5.2	Sensor Extension with Vertical Compact Version	8
2.5.3	Sensor extension with horizontal compact version	9
2.5.4	Double Sensor Extension with Remote Version- Wall Bracket	9
2.5.5	Double Sensor Extension with Remote Version- Remote Converter Housing	10
2.5.6	Remote Version - Probe Electronic Housing	10
2.5.7	Double Sensor extension with remote version- Probe Electronic Housing	10
2.5.8	Probe Options	11
2.6	Model Chart	12
3	Installations	13
3.1	Preinstallation Instructions	13
3.2	Installation for liquids	13
3.3	General Instruction for Device Installation on the Tank	14
3.3.1	Single Rod Probe (Single-Piece Probe)	14
3.3.2	Assemble the $\varnothing\frac{1}{4}$ " ($\varnothing 8\text{mm}$) single rod probe (segmented probe)	15
3.3.3	Assemble the segmented $\varnothing\frac{3}{4}$ " ($\varnothing 22\text{mm}$) coaxial probe	17
3.3.4	Installation with a Flange Connection	19
3.3.5	Installation with Threaded Connection	19
3.3.6	Installation of Cable Probe in The Tank	20
3.3.7	Pits and Tanks Made of Non-Conductive Materials	20
3.3.8	Transmitter Remove and Turn	21
3.3.9	Installation of the Wall Support for the Remote Converter	22
3.3.10	Install Wall Supports for Devices with the Sensor Extension	22

3.3.11	Attachment of Weather Protection to Device	23
3.3.12	Weather Protection Opening Process	25
4	Electrical Connection	25
4.1	General Instructions	26
4.2	2-Wire, Loop Powered	26
4.2.1	Compact and Remote Version	26
4.3	Electrical Connection for Current Output	30
4.3.1	Non-Ex Device	30
5	Operations.....	31
5.1	Digital Display Screen.....	31
5.1.1	Local Display Screen	31
5.2	Normal Mode	32
5.3	Configuration Mode.....	35
5.3.1	General Instruction.....	35
5.3.2	Access to the Auto Setup Procedure	35
5.3.3	Menu Overview	35
5.3.4	Keypad Functions	36
5.3.5	Function Description	38
5.4	Device Configuration	58
5.4.1	Second Output.....	58
5.4.2	Relay Output.....	59
5.4.3	Device Protection Setting	61
5.4.4	HART Network Configuration	62
5.4.5	Distance and Interface Distance measurement.....	62
5.4.6	Level and Interface Level Measurement	63
5.4.7	Configuration of the Device for mass and Volume	65
5.4.8	Dynamic Gas-phase Compensation (DGC).....	67
5.4.9	Threshold and Interference Signal.....	69
5.4.10	Process to Decrease Length of Probe	72
6	Maintenance.....	73
6.1	Periodic Maintenance	73
6.2	Device Cleaning Instructions	73
6.3	Replacement of Device Components	73
6.4	Availability of Services	73
6.5	Return Device to Manufacture	74
6.6	Disassembling and Recycling	74
6.6.1	Compact Version	75
6.6.2	Sensor Extension with Compact Version	79
6.6.3	Remote Version.....	81
6.6.4	Double sensor extension with remote version (D)	85
7	Troubleshooting.....	86
7.1	Status and Error Message.....	86
7.1.1	Device Status	86
7.1.2	Error Handling	88

1 Safety Instructions

1.1 Intended Use

Tek-Flex 4100A Explosion-Proof Guided Wave Radar Level Transmitter mostly used in liquid storage and process applications.

1.2 Certifications

CE and Class I Div 1 Approval.

1.3 Safety Instructions from the Manufacturer

1.3.1 Disclaimer

The manufacturer will not be held accountable for any damage that happens by using its product, including, but not limited to direct, indirect, or incidental and consequential damages.

Any product purchased from the manufacturer is warranted in accordance with the relevant product documentation and our Terms and Conditions of Sale.

The manufacturer has the right to modify the content of this document, including the disclaimer, at any time for any reason without prior notice, and will not be answerable in any way for the possible consequence of such changes.

1.3.2 Product Liability and Warranty

The operator shall bear authority for the suitability of the device for the specific application. The manufacturer accepts no liability for the consequences of misuse by the operator. Wrong installation or operation of the devices (systems) will cause the warranty to be void. The respective Terms and Conditions of Sale, which forms the basis for the sales contract shall also apply.

1.3.3 Information Concerning the Documentation

To prevent any injury to the operator or damage to the device it is essential to read the information in this document and the applicable national standard safety instructions. This operating manual contain all the information that is required in various stages, such as product identification, incoming acceptance and storage, mounting, connection, operation, and commissioning, troubleshooting, maintenance, and disposal.

1.4 Safety Precautions

You must read these instructions carefully prior to installing and commissioning the device. These instructions are an important part of the product and must be kept for future reference. Only by observing these instructions, optimum protection of both personnel and the environment, as well as safe and fault-free operation of the device can be ensured.

For additional information that are not discussed in this manual, contact the manufacturer.

Warnings and Symbols Used

The following safety symbol marks are used in this operation manual and on the instrument.



WARNING

Indicates a potentially hazardous situation which, if not avoided, could result in death or severe injury



CAUTION

Indicates a potentially hazardous situation which, if not avoided, may result in minor or moderate injury. It may also be used to alert against unsafe practices.



NOTE

Indicates that operating the hardware or software in this manner may damage it or lead to system failure.

1.5 Packaging, Transportation and Storage

1.5.1 Packaging

The original package consists of

1. Tek-Flex 4100A Explosion-Proof Guided Wave Radar Level Transmitter
2. Documentation



NOTE

Unpack and Check the contents for damages or sign of rough handling. Report damage to the manufacturer immediately. Check the contents against the packing list provided.

1.5.2 Transportation

- Avoid impact shocks to the device and prevent it from getting wet during transportation.
- Verify local safety regulations, directives, and company procedures with respect to hoisting, rigging, and transportation of heavy equipment.
- Transport the product to the installation site using the original manufacturer's packing whenever possible.

1.5.3 Storage

If this product is to be stored for a long period of time before installation, take the following precautions:

- Store your product in the manufacturer's original packing used for shipping.
- Storage location should conform to the following requirements:
 1. Free from rain and water
 2. Free from vibration and impact shock
 3. At room temperature with minimal temperature and humidity variation
- Properties of the instrument can change when stored outdoors.

1.5.4 Nameplate

The nameplate lists the order number and other important information, such as design details and technical data.

i NOTE

Check the device nameplate to ensure that the device is delivered according to your order. Check for the correct supply voltage printed on the nameplate.

2 Product Description

2.1 Introduction

The Tek-Flex 4100A Explosion-Proof Guided Wave Radar Level Transmitter measures distance, level, interface, mass and volume of liquids, pastes and slurries. It uses a probe to guide a signal to the measured product's surface; therefore, it can measure under challenging conditions. Tek-Flex 4100A performance is not affected by Dust, foam, vapor, heated surfaces, boiling surfaces, pressure, temperature, and density changes. Tek-Flex 4100A signal converter has four versions: compact, sensor extension with compact version, remote version and double sensor extension with remote version. This signal converter is arranged with horizontal or vertical housing options for easy access to the device terminals and the optional display.



Fig 1: Tek-Flex 4100A

2.2 Measuring Principle

The Tek-Flex 4100A Explosion-Proof Guided Wave Radar (TDR) Level Transmitter is developed from a proven technology called Time Domain Reflectometry (TDR). It transmits low-intensity electromagnetic pulses of approximately one nanosecond width along a rigid or flexible conductor. These pulses transfer at the speed of light. When the pulses reach the surface of the product to be measured it get reflected with an intensity that depends on the dielectric constant (ϵ_r) of the product (for example, water has a high dielectric constant and reflects the pulse to the signal converter at 80% of its original intensity).

The device measures the time duration from the pulse emission to received. Half of this time is equivalent to the distance from the device's reference point (the flange facing) to the product's surface. The measured time is converted into an output current of 4 to 20mA and/or a digital signal.

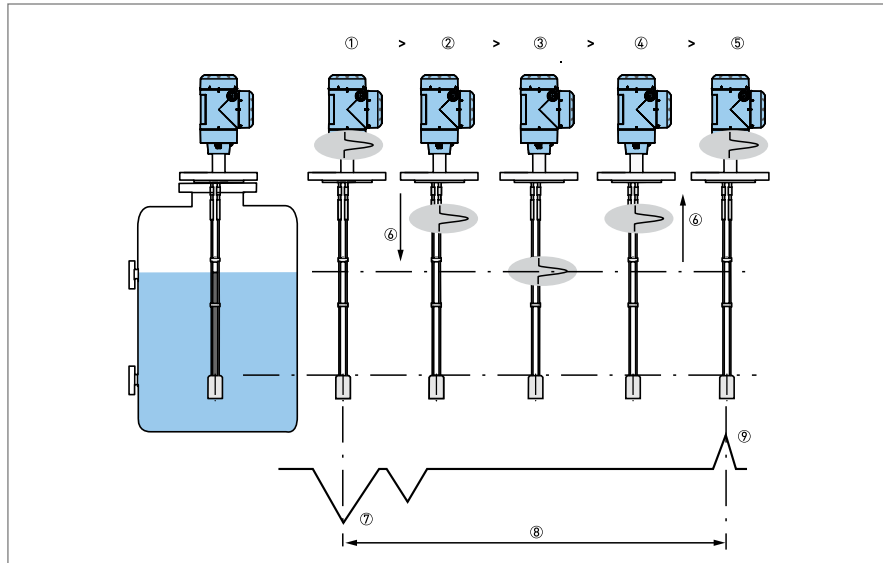
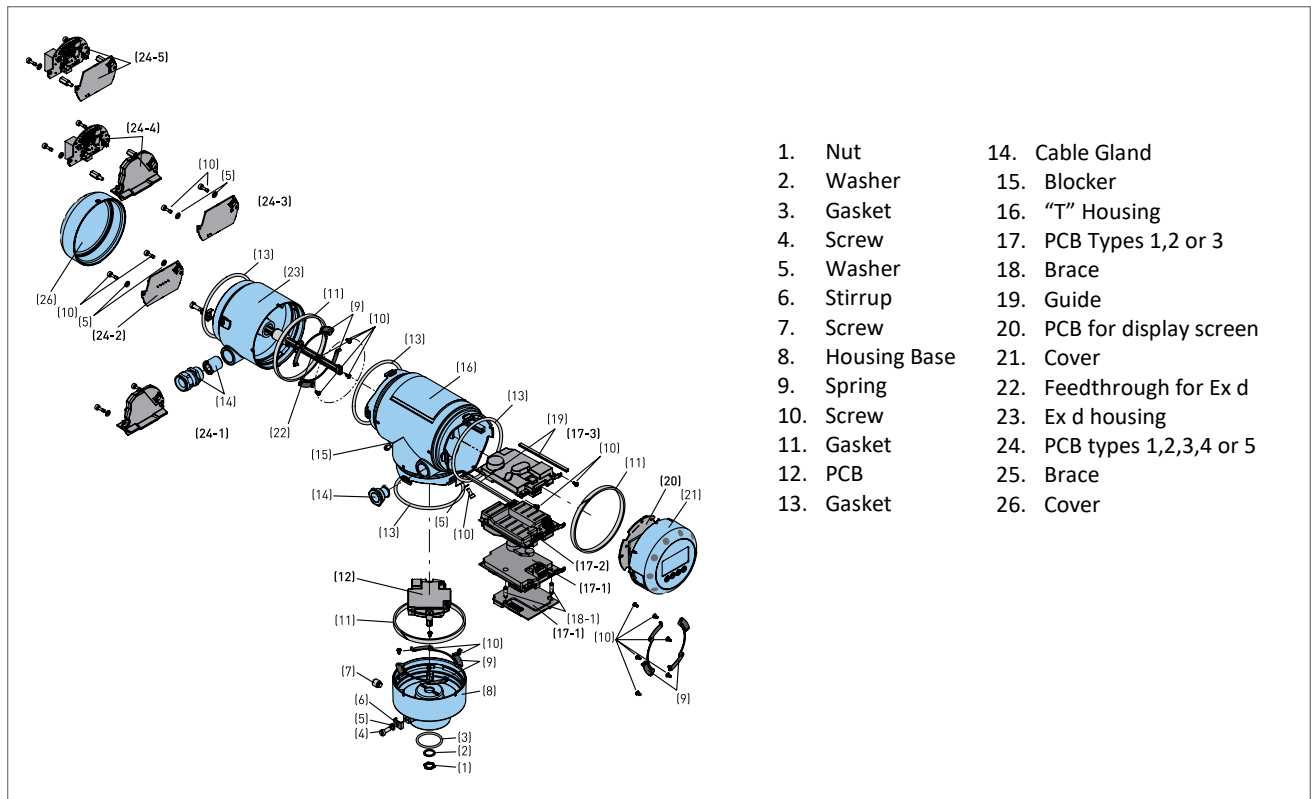

Fig 2: Measuring Principle of Tek-Flex 4100A

Where,

1. Time 0: The electromagnetic (EM) pulse is transmitted by the converter.
2. Time 1: The pulse goes down the probe at the speed of light in air, V_1 .
3. Time 2: The pulse is reflected.
4. Time 3: The pulse goes up the probe at speed, V_1 .
5. Time 4: The converter receives the pulse and records the signal.
6. The electromagnetic pulse transfer at speed, V_1 .
7. Transmitted electromagnetic pulse.
8. Half of this time is equivalent to the distance from the reference point of the device (the flange facing) to the surface of the product.
9. Received electromagnetic pulse.

2.3 Components of Tek-Flex 4100A



- | | |
|-----------------|----------------------------|
| 1. Nut | 14. Cable Gland |
| 2. Washer | 15. Blocker |
| 3. Gasket | 16. "T" Housing |
| 4. Screw | 17. PCB Types 1,2 or 3 |
| 5. Washer | 18. Brace |
| 6. Stirrup | 19. Guide |
| 7. Screw | 20. PCB for display screen |
| 8. Housing Base | 21. Cover |
| 9. Spring | 22. Feedthrough for Ex d |
| 10. Screw | 23. Ex d housing |
| 11. Gasket | 24. PCB types 1,2,3,4 or 5 |
| 12. PCB | 25. Brace |
| 13. Gasket | 26. Cover |

Fig 3: Components of Tek-Flex 4100A

2.4 Specifications

Accuracy	<p>Standard:</p> <ul style="list-style-type: none"> ±2mm / ±0.08" (distance ≤ 10m / 33ft) ±0.02% of measured distance (distance > 10m / 33ft) <p>Interface:</p> <ul style="list-style-type: none"> ±5mm / ±0.2" (distance ≤ 10m / 33ft) ±0.05% of measured distance (distance > 10m / 33ft)
Probe Options	<p>Single Rod (1/4" (Ø8mm)): Single-Piece or Segmented Type.</p> <p>Single Rod (3/8" (Ø10mm)): Single-piece fully PTFE coated; Single Cable (1/8" (Ø4mm))</p>
Measuring Range	<p>Single-Piece or Single-piece fully PTFE coated: 3.28 to 13.12ft (0.6 to 4m);</p> <p>Segmented: 3.28 to 19.69ft (0.6 to 6m);</p> <p>Single Cable: 3.28 to 196.85ft (1 to 60m)</p>
Resolution	0.004" (0.1mm)
Repeatability	±0.04" (±1mm)
Temperature Limits	+59 to +77°F (+15 to +25°C)
Operating Temperature	-58 to +482°F (-50 to +250°C); -58 to +302°F (-50 to 150°C)
Ambient Temperature	-40 to +176°F (-40 to +80°C)
Storage Temperature	-58 to +185°F (-50 to +85°C)
Pressure Limits	<p>Single fully PTFE-coated: -14.5 to 580 psig (-1 to 40 barg);</p> <p>Single ceramic process seal system: -14.5 to 1450 psig (-1 to 100 barg);</p>
Humidity	60% ±15%
Viscosity	10000mPa·s / 10000 cP

Dielectric Constant	≥ 1.6 in direct mode (interface: $\epsilon_r(\text{interface}) \gg \epsilon_r(\text{level})^2$)
Material	316L SS; Hastelloy C; PTFE
Process Connection	Thread, Flange
Output Signal	4 to 20mA or HART output
Power Supply	11.5 to 30 VDC; 13.5 to 34 VDC
Display	LCD display (128 × 64 pixels in 8-step greyscale with 4-button keypad)
Protection Class	IP68; IP66
Enclosure	NEMA 4x
Approvals	cQPSus XP-IS/DIP-IS CL I DIV 1 GP A-G + CL I Z1 AEx db ia/Ex db ia IIC T6...T' Gb + Z21 AEx ia tb/Ex ia tb IIIC T85°C...T ¹⁰ C Db

2.5 Dimensional Drawings

2.5.1 Signal converter and probe electronics options

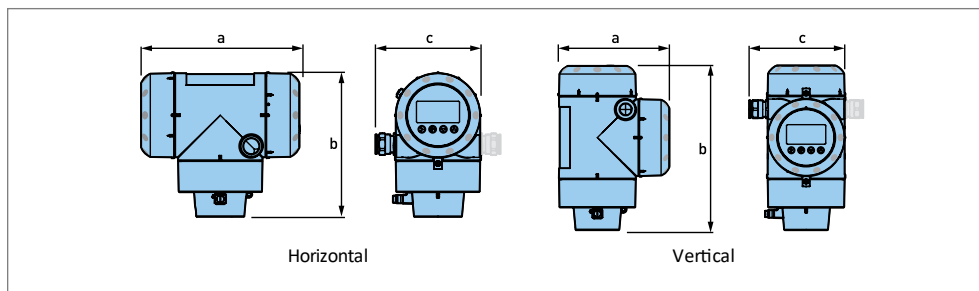

Fig 4: Compact version

	a in(mm)		b in (mm)		c in(mm)	
	Horizontal	Vertical	Horizontal	Vertical	Horizontal	Vertical
Non-Ex / Ex i / IS	7 ½" (191)	5 ¾" (147)	7" (175)	8 ¾" (218)	5" (125)	5" (125)
Optional output / Ex d / XP	10 ¼" (258)	8 ½" (210)	7" (175)	8 ¾" (218)	5" (125) [6 1/8" (153)]	5" (125) [6 1/8" (153)]

*Note: Use the dimension in square brackets if the device has 2 current outputs or a switch output (relay)

2.5.2 Sensor Extension with Vertical Compact Version

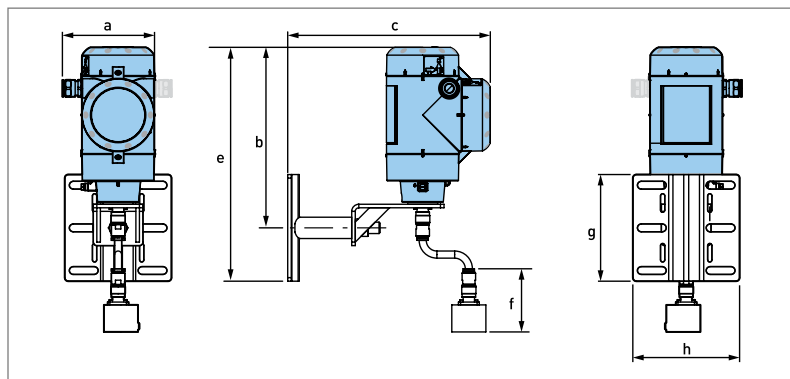

Fig 5: Vertical Sensor Extension

	a in(mm)	b in (mm)	c in(mm)	e in(mm)	f in(mm)	g in(mm)	h in(mm)
Non-Ex / Ex i / IS	5" (125)	10" (250)	11 ¼" (280.75)	13 ¼" (329)	3 ½" (89)	6" (150)	6" (150.4)

Optional output / Ex d / XP	5" (125) [6 1/8" (153)]	10" (250)	13 3/4" (348.4)	13 1/4" (329)	3 1/2" (89)	6" (150)	6" (150.4)
-----------------------------	-------------------------	-----------	-----------------	---------------	-------------	----------	------------

*Note: Use the dimension in square brackets if the device has 2 current outputs or a switch output (relay).

2.5.3 Sensor extension with horizontal compact version

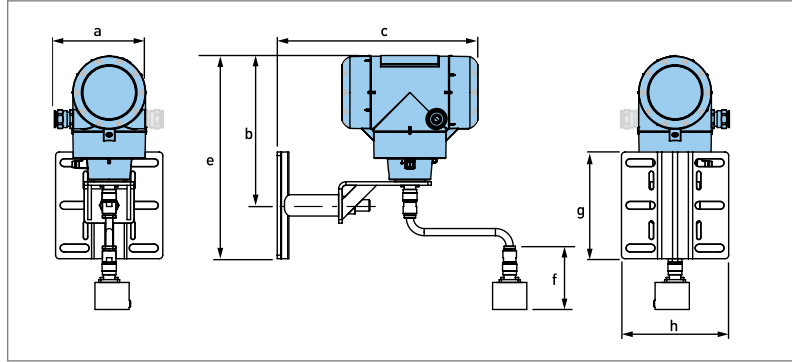

Fig 6: Horizontal Sensor Extension

	a in(mm)	b in (mm)	c in(mm)	e in(mm)	f in(mm)	g in(mm)	h in(mm)
Non-Ex / Ex i / IS	5" (125)	8 1/2" (211)	11 1/4" (281)	11 1/2" (285)	3 1/2" (89)	6" (150)	6" (150.4)
Optional output / Ex d / XP	5" (125) [6 1/8" (153)]	8 1/2" (211)	13 3/4" (344)	11 1/2" (285)	3 1/2" (89)	6" (150)	6" (150.4)

*Note: Use the dimension in square brackets if the device has 2 current outputs or a switch output (relay)

2.5.4 Double Sensor Extension with Remote Version- Wall Bracket

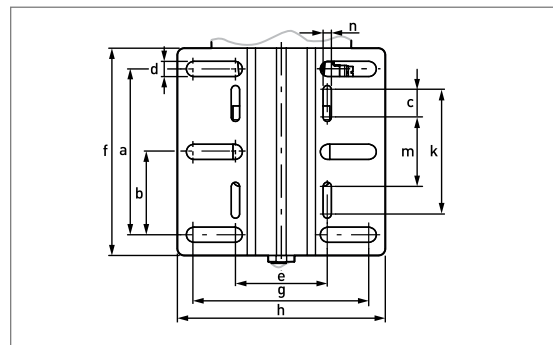

Fig 7: Wall Bracket

	a in(mm)	b in (mm)	c in(mm)	d in (mm)	e in(mm)	f in(mm)	g in(mm)	h in(mm)	k In (mm)	m in (mm)	n in (mm)
Wall Bracket	4 3/4" (120)	2 1/4" (60)	3/4" (20)	3/8" (10)	2 3/4" (67.4)	6" (150)	5" (126.4)	6" (150.4)	3 1/2" (90)	2" (50)	1/4" (6)

2.5.5 Double Sensor Extension with Remote Version- Remote Converter Housing

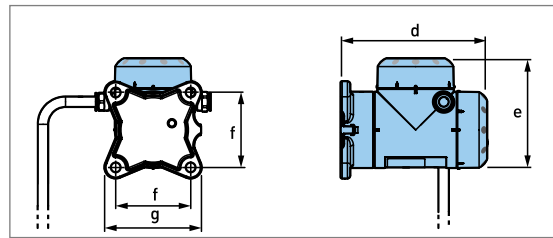

Fig 8: Remote Converter Housing

	d in(mm)	e in (mm)	f in(mm)	g in(mm)
Non-Ex / Ex i / IS	7 ¾" (195)	5 ¾" (146)	4" (100)	5 ¼" (130)
Optional output / Ex d / XP	7 ¾" (195)	5 ¾" (146)	4" (100)	5 ¼" (130)

2.5.6 Remote Version - Probe Electronic Housing

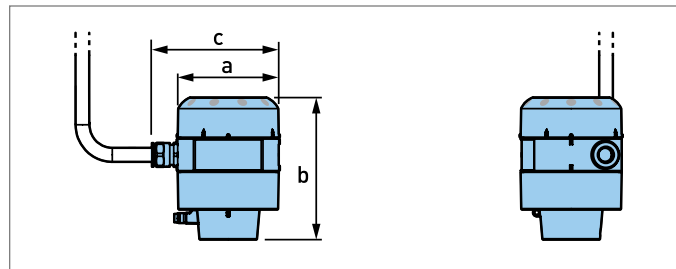

Fig 9: Probe Electronic Housing

	a in(mm)	b in (mm)	c in(mm)
Non-Ex / Ex i / IS	4 ¼" (104)	5 ¾" (142)	4" (100)
Optional output /Ex d / XP	7 ¾" (195)	5 ¾" (146)	4" (100)

2.5.7 Double Sensor extension with remote version- Probe Electronic Housing

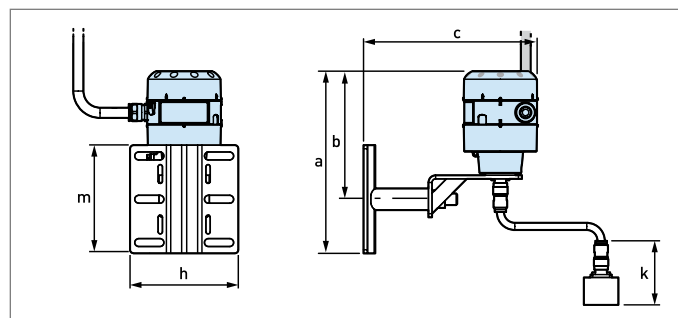
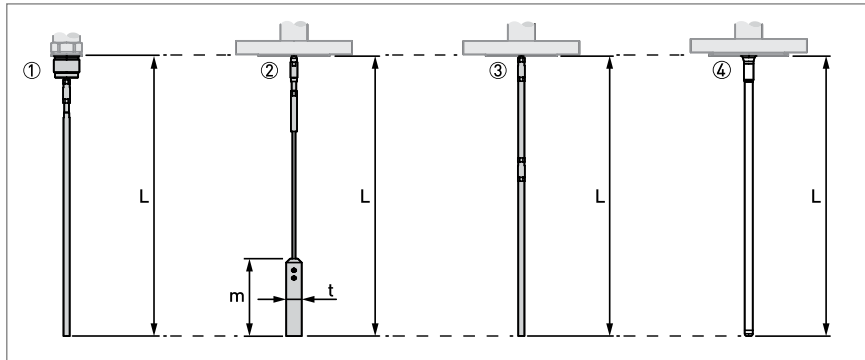

Fig 10: Double Sensor Extension-Probe Electronics Housing

	a in(mm)	b in (mm)	c in(mm)	h in (mm)	k in(mm)	m in(mm)
Probe Electronics Housing with Sensor Extension	10 1/8" (252.3)	7 1/8" (177.3)	9 ¾" (241)	6" (150.4)	3 ½" (88.9)	6" (150)

2.5.8 Probe Options
2.5.8.1 Single Probe



1. Single rod 1/4" (Ø8mm)
2. Single cable 1/8" (Ø4mm)
3. Single rod 1/4" (Ø8mm) (segmented version)
4. Single rod 1/8" (Ø8mm) with PTFE coating

Fig 11: Single Probes

Probes	L min in (mm)	L Max in (mm)	m in (mm)	t in (mm)
Single rod 1/4" (Ø8mm)	24" (600)	160" (4000)	-	-
Single cable 1/8" (Ø4mm)	40" (1000)	2400" (60000)	4" (100)	3/4" (20)
Single rod 1/4" (Ø8mm) (segmented version)	24" (600)	240" (6000)	-	-
Single rod 1/8" (Ø8mm) with PTFE coating	24" (600)	160" (4000)	-	-

2.5.8.2 Probe end options for the Ø1/8" (Ø4mm) single cable probe

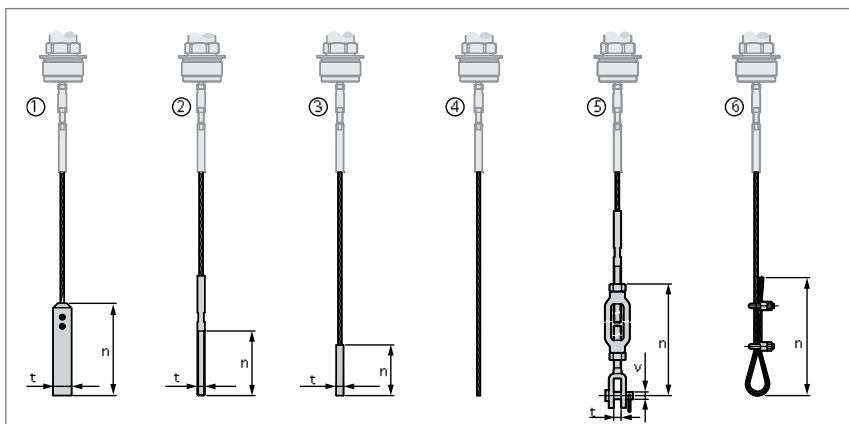

1. Standard Counterweight
2. Threaded End
3. Crimped End
4. Open End
5. Turnbuckle
6. Chuck

Fig 12: Probe End Options

Probe End Type	n in (mm)	t in (mm)	v in (mm)
Counterweight	4" (100)	Ø3/4" (Ø20)	-
Threaded end	2 3/4" (70)	M8	-
Crimped end	2 1/4" (55)	Ø1/4" (Ø8)	-
Open end	-	-	-
Turnbuckle	6 3/4" (172)	3/8" (11)	Ø1/4" (Ø6)
Chuck	12" (300)	-	-

2.6 Model Chart

Example	Tek-Flex 4100A	00	01	01	A	A	XXX	01	A	DGC	Tek-Flex 4100A-00-01-01-A-A-XXX-01-A-DGC
Series	Tek-Flex 4100A										Explosion-Proof Guided Wave Radar Level Transmitter
Approval		00 01 02									Without ATEX 1 1 1 G Ex ia IIC T6 Ga + 1 1 1 D Ex ia IIIC Da cQPSus XP-IS/DIP-IS CL I DIV 1 GP A-G + CL I Z1 AEx db ia/Ex db ia IIC T6...T' Gb + Z21 AEx ia tb/Ex ia tb IIIC T85°C...T ¹ °C Db
Wetted Material/Pressure			01 02								316L SS HASTELLOY® C
Probe type				01 02 03 04 05 06 07 08 09 10 11 12 13 14							Single rod Ø1/4" (Ø8mm) max. 4m (13.12ft) Single rod Ø1/4" (Ø8mm) segmented max.6m (19.69ft) Single rod Ø3/8" (Ø10mm) max. 4m (13.12ft) Single cable Ø1/8" (Ø4mm) max. 60m (196.85ft) counterweight 3/4"X 4" (20x100mm) Single cable Ø1/8" (Ø4mm) max. 60m (196.85ft) turnbuckle Single cable Ø1/8" (Ø4mm) max. 60m (196.85ft) chuck Single cable Ø1/8" (Ø4mm) max. 60m (196.85ft) threaded end Single cable Ø1/8" (Ø4mm) max. 60m (196.85ft) crimped end Single cable Ø1/8" (Ø4mm) max. 60m (196.85ft) open end Coaxial Ø3/4" (Ø22mm) max.6m (19.69ft) Coaxial Ø3/4" (Ø22mm) segmented max.6m (19.69ft) Double rod 2x Ø1/4" (Ø8mm) max. 4m (13.12ft) Double cable 2xØ1/8" (Ø4mm) max. 14m(45.93ft) counterweight 1 1/2"X 2 1/4" (40X60mm) Reversed interface Ø3/8" (Ø10mm) max. 4m (13.12ft)
Temperature					A B C						(-40 to +392°F (-40 to +200°C)) (-4 to +392°F (-20 to +200°C)) Standard / -50 to +150°C (-58 to +302°F)
Process connection						A B C D E					3/4" NPT 1 NPT 1½ NPT 2" 150lb RF ASME B16.5 2" 300lb RF ASME B16.5
Probe Length							XXX				Probe length in inches
Output								01 02 03			2-wire / 4 to 20mA passive HART® 2 x 2-wire / 4 to 20mA passive HART® + 4 to 20mA passive 2-wire + 4-wire / 4 to 20mA passive HART® + switch output - relay (48VDC / 6 A; 24VDC / 6A)
Orientation									A B		Horizontal Vertical
Options										DCG CC WP TAG	Dynamic Gas-phase Compensation (DGC) Calibration Certificate Weather Protection Stainless Steel Tag Plate

3 Installations

This section covers instruction on installations and commissioning. Installations of the device must be carried out by trained, qualified specialists authorized to perform such works.



CAUTION

- When removing the instrument from hazardous processes, avoid direct contact with the fluid and the meter.
- All installation must comply with local installation requirements and local electrical code.

3.1 Preinstallation Instructions

- Ensure sufficient space on all sides.
- Heat sources (sunlight, adjacent system components, etc.) can cause damage by increasing internal temperature of the device. Ensure the internal temperature does not exceed maximum limit.
- The maximum ambient temperature is +75°C / +167°F.
- The maximum surface temperature is +80°C / +176°F.
- Install the weather protection accessory when necessary to decrease internal temperature.
- Do not subject the signal converter to heavy vibrations.

3.2 Installation for liquids

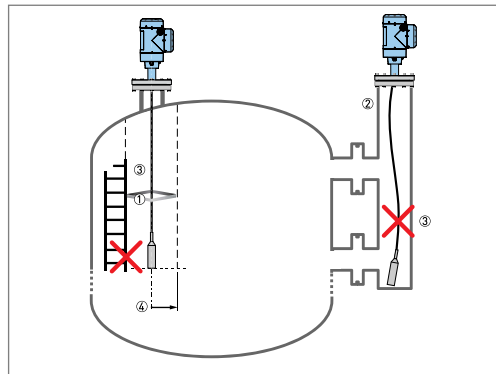
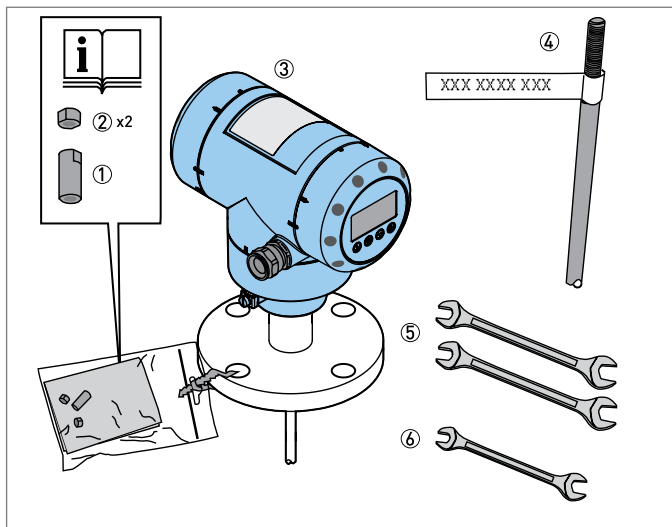

Fig 13: Installation for Liquid

- The device generates the electromagnetic (EM) field. It has a radius of R_{min} .
- Ensure the EM field is clear of objects and product flow.
- Install a bypass chamber or stilling well if there are too many objects in the tank.
- Keep the probe straight.
- If the probe is too long, shorten the probe length.
- Ensure the device is configured with the new probe length.

3.3 General Instruction for Device Installation on the Tank

3.3.1 Single Rod Probe (Single-Piece Probe)



1. Union Nut
2. 2 Locking Nuts
3. Housing Assembly
4. Single Rod Probe
5. Tools: Two 8mm Open-Ended Wrenches (Not Supplied)
6. Tools: One 7mm Open-Ended Wrench (Not Supplied)

Fig 14: Equipment to Assemble the Device

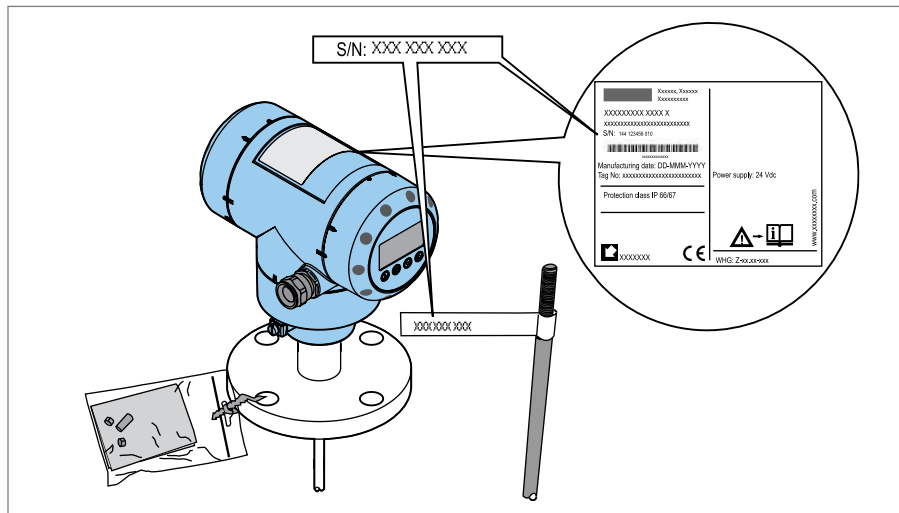

Fig 15: Check Serial Number on Each Component

- Ensure the housing and the single rod have the same serial numbers.
- Remove the sticker from the probe.

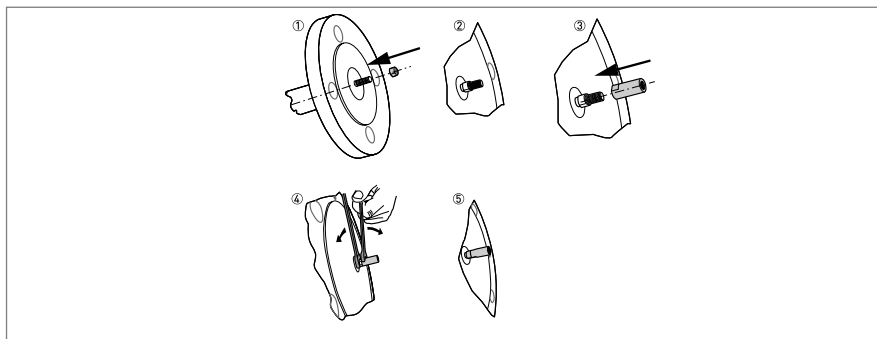

Fig 16: Attachment of Locking and Union Nuts

1. Attach a locking nut to the threaded rod below the process connection.
2. Ensure the nut is fully engaged on the thread.
3. Attach the union nut to the threaded rod below the process connection.
4. Tighten both nuts with the two 8mm open-ended wrenches.

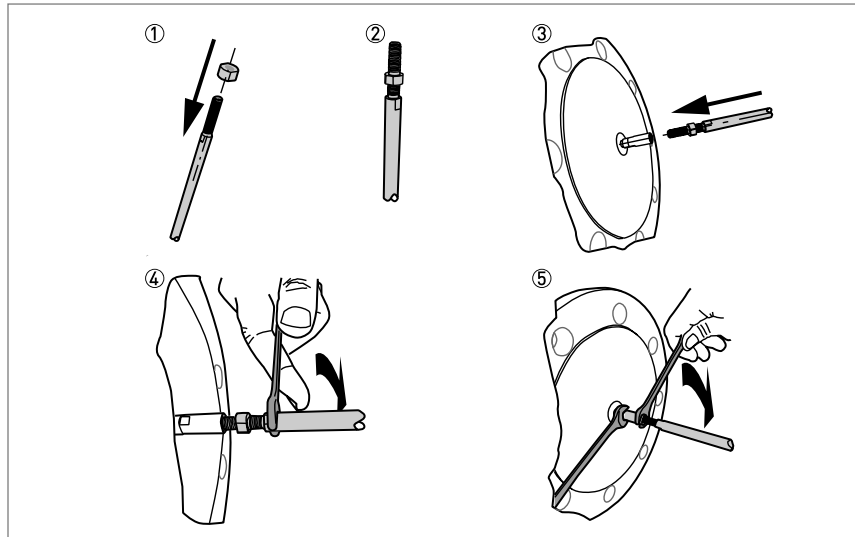

Fig 17: Attachment of Locking and Union Nuts to Single Rod

1. Attach a locking nut to the single rod.
2. Ensure the locking nut is engaged $\frac{3}{4}$ along the length of the thread.
3. Attach the single rod to the union nut. Ensure the probe touches the threaded rod below the process connection.
4. Tighten the single probe with a 7mm open-ended wrench.
5. Tighten the locking nut against the union nut with two 8mm open-ended wrenches.

3.3.2 Assemble the $\frac{1}{4}$ " ($\varnothing 8\text{mm}$) single rod probe (segmented probe)

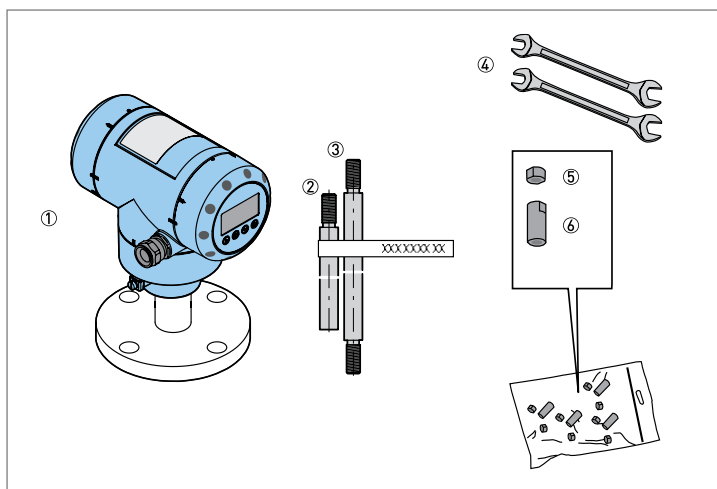

Fig 18: Equipment to assemble the single rod probe (segmented)

1. Converter and Process Connection
2. Bottom (quantity: 1) segment of the rod probe
3. Top and middle (if more than one) segments of the rod probe
4. Tools: two 8mm open-end wrenches (not supplied)
5. Lock nuts (2 lock nuts per segment)
6. Union nut (1 union nut per segment)

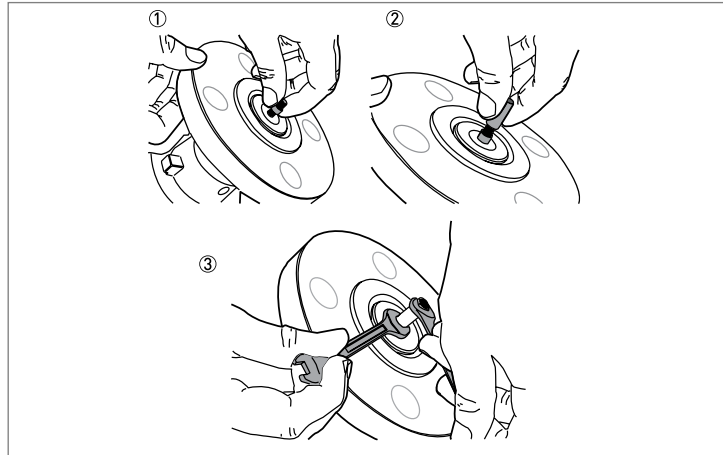

Fig 19: Assemble the Segmented Single Rod Probe part 1.

1. Attach a lock nut to the threaded rod below the process connection. Ensure the nut is fully engaged on the thread.
2. Attach a union nut to the threaded rod below the process connection.
3. Use two 8mm open-end wrenches to tighten the union nut against the lock nut.

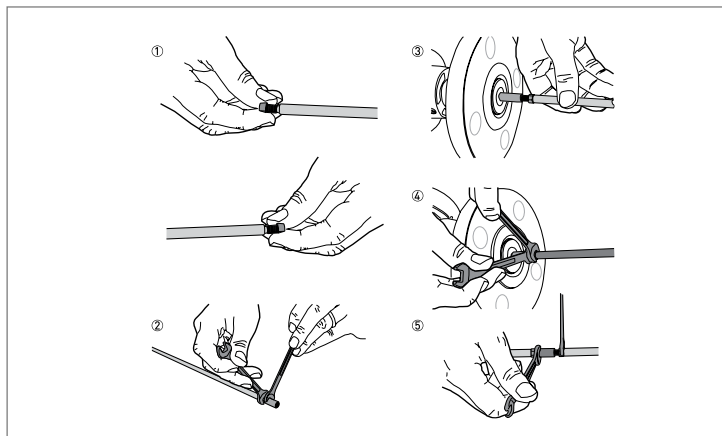

Fig 20: Assemble the Segmented Single Rod Probe part 2.

1. Attach a lock nut to each end of the rod probe segments.
2. Attach a union nut to the bottom end of each rod probe segment, but not to the bottom segment. Use two 8mm open-end wrenches to tighten the union nut against the lock nut.
3. Attach the top segment of the rod probe to the union nut below the process connection. Use two 8mm open-end wrenches to tighten the union nut against the lock nut on the rod probe.
4. Attach the middle segment of the rod probe to the union nut on the top segment (if there are middle segments). Use two 8mm open-end wrenches to tighten the union nut against the lock nut. Repeat this step for the other segments.
5. Attach the bottom segment of the rod probe to the union nut on the top segment. Use two 8mm open-end wrenches to tighten the union nut against the lock nut.

3.3.3 Assemble the segmented $\frac{3}{4}$ " ($\varnothing 22\text{mm}$) coaxial probe.

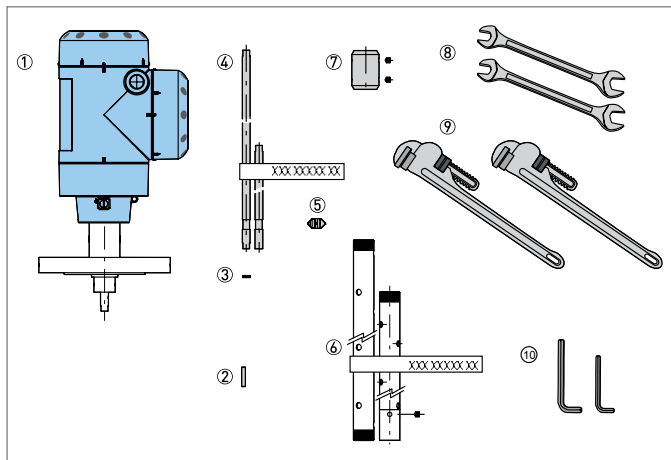

Fig 21: Equipment to assemble the coaxial probe.

1. Converter and process connection
2. HC M4x20 screws (1 screw per probe segment)
3. Lock washers (1 pair of washers per probe segment)
4. Top / middle (quantity: 1 or more) and bottom (quantity: 1 – with 1 socket set screw M5x5) segments of the signal rod
5. PTFE spacer (1 spacer per probe segment)
6. Middle (quantity: 1 or more) and bottom (quantity: 1) segments of the coaxial tube
7. Union nut with 2 sockets set screws M5x5 (1 union nut per segment of the coaxial tube)
8. Tools: two 7mm open-end wrenches (not supplied)
9. Tools: two pipe (Stillson) wrenches (not supplied)
10. Tools: one 2.5mm Allen wrench and one 2mm Allen wrench (not supplied)

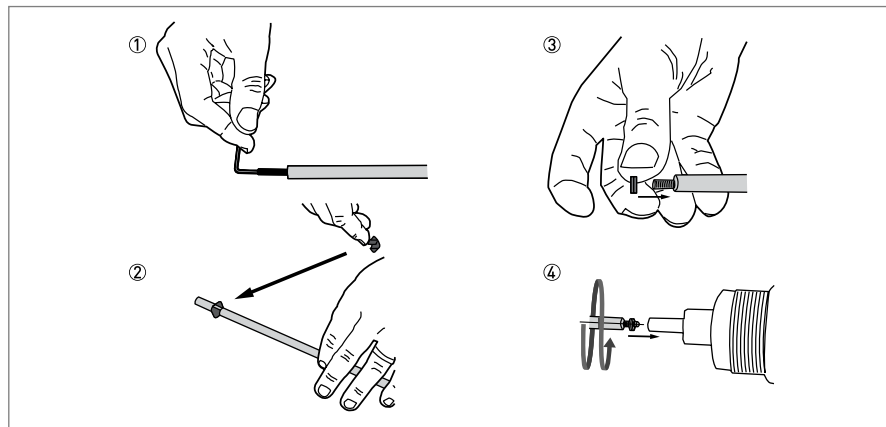

Fig 22: Assemble the Segmented Coaxial Probe Part 1

1. Use a 2mm Allen wrench to attach and tighten a HC M4x20 screw at the top of each rod segment (intermediary and end rod segments).
2. Attach a PTFE spacer to the end of each rod segment that has a groove.
3. Attach a pair of lock washers at the top of each rod segment (intermediary and end rod segments).
4. Assemble one of the middle rod segments (with a pair of lock washers on the attached screw) and the signal rod below. Use two 7mm open-ended wrenches to tighten the assembled parts to a torque of 2 to 3 N·m.

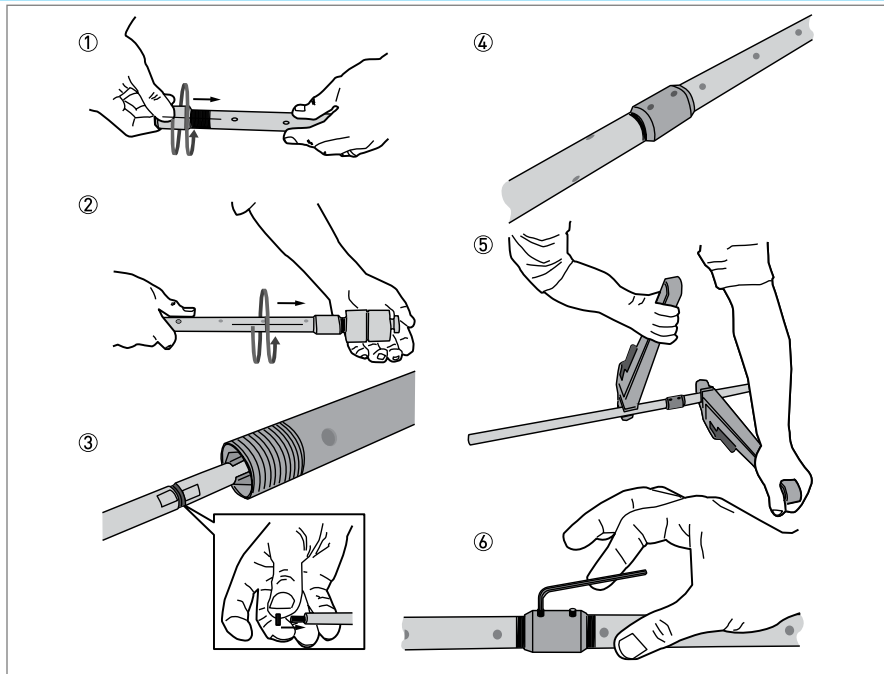

Fig 23: Assemble the Segmented Coaxial Probe Part 2

1. Attach a union nut to each coaxial tube (middle and end tubes)
2. Attach a middle tube segment to the coaxial probe stem. Do not use tools to tighten the assembled parts.
3. Assemble the next middle rod segment (with a pair of lock washers on the attached screw) and the top rod segment. Use two 7mm open-ended wrenches to tighten the assembled parts to a torque of 2 to 3 N·m.
4. Assemble the next coaxial tube segment and the top coaxial tube segment. Do not use tools to tighten the assembled parts. Do steps (9) thru (10) again until the end rod segment and end coaxial tube are attached.
5. Use the 2 pipe wrenches to tighten the coaxial tubes in the lock nuts.
6. Use a 2.5mm Allen wrench to attach and tighten the two HC M5×5 screws (lock screws) to the union nut.

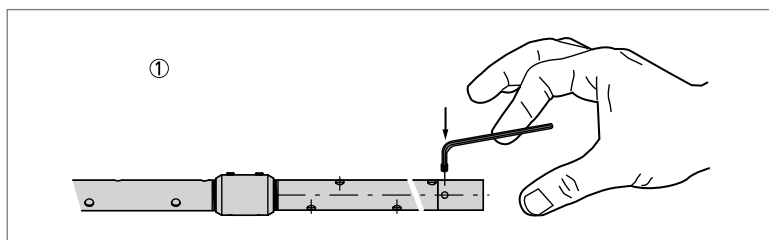

Fig 24: Assemble the Segmented Coaxial Probe Part 3

1. Use a 2.5mm Allen wrench to attach and tighten a HC M5×5 screw (lock screw) to the bottom segment of tube.

3.3.4 Installation with a Flange Connection

- Require Equipment:
 - Device
 - Gasket (not supplied)
 - Wrench (not supplied)

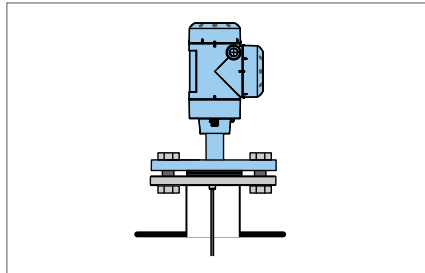

Fig 25: Flange Connection

- Ensure the flange on the nozzle is level.
- Ensure you use the applicable gasket for the flange and the process.
- Align the gasket correctly on the flange facing of the nozzle.
- Lower the probe carefully into the tank.
- Tighten the flange bolts.

3.3.5 Installation with Threaded Connection

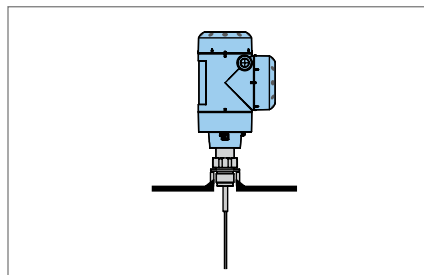

Fig 26: Threaded Connection

- Ensure the tank connection is level.
- Ensure you use the applicable gasket for the connection and the process.
- Align the gasket correctly.
- If the device is installed on a tank made of plastic or other non-conductive material, refer to Recommendations for pits and tanks made of non-conductive materials.
- Lower the probe carefully into the tank.
- Use 36mm wrench to attach the process connection to the tank.
- Tighten the nut.

i NOTE

If there is insufficient clearance to install the device, remove the housing. Install the probe and then put the housing back on the process connection.

3.3.6 Installation of Cable Probe in The Tank

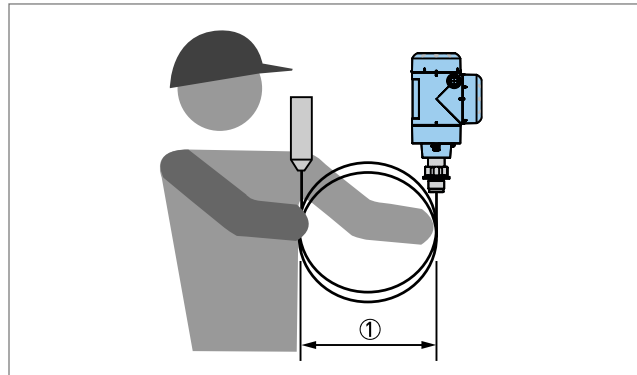

Fig 27: Wind Cable Probes and Electrical Cables

1. Do not wind cable probes less than 20" (500mm) in diameter.



WARNING

If you bend the probe too much, you will damage the device and it will not measure accurately.

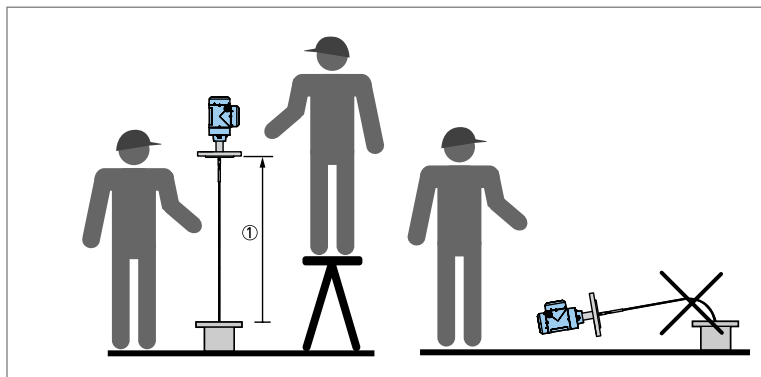

Fig 28: Installation of devices with cable probes

1. >1 m / 3½ft
 - Use two persons to lift the housing and the probe above the process connection.
 - Hold the device 1m / 3½ft above the tank.
 - Unwind the probe carefully into the tank.

3.3.7 Pits and Tanks Made of Non-Conductive Materials

If you have a device with a single rod or a single cable probe and a thread connection, follow below instructions:

- Please put a metal sheet between the device and the process connection.
 - It must have a diameter equal to or larger than 8" (200mm).
- Ensure the metal sheet is in contact with the thread stop on the device.

- Please use a flange with an external diameter equal or larger than 8" (200mm).
- If you have a device with a double rod, double cable, or coaxial probe, you can ignore these instructions.

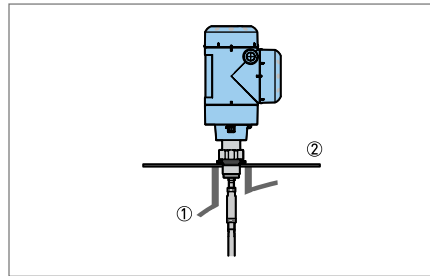

Fig 29: Installation in a non-metallic tank or pit with a thread connection

1. Non-metallic (plastic etc.) tank or pit.
2. Metal sheet, $\varnothing \geq 8''$ (200mm).



CAUTION

When the device is installed, ensure the tank roof has no deformation.

3.3.8 Transmitter Remove and Turn

The transmitter turns 360°. The transmitter can be removed from the process connection assembly under process conditions.

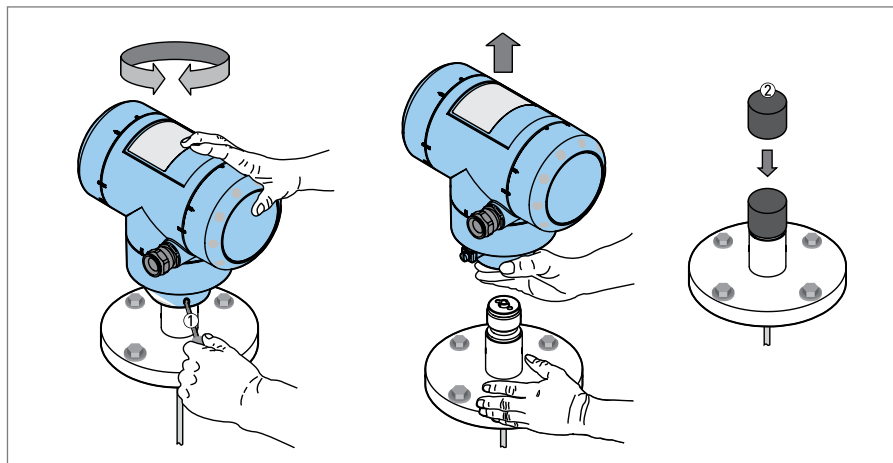

Fig 30: Transmitter Remove and Turn Process

1. Tool: 5mm Allen wrench (not supplied) for the lock screw on the signal converter.
2. Cover for the coaxial hole on top of the process connection assembly (not supplied).



CAUTION

-
- If you remove the housing, put a cover on the coaxial hole on top of the process connection assembly.
 - Ensure the housing is fully engaged to the process connection before you tighten the lock screw with the 5mm Allen wrench.
-

3.3.9 Installation of the Wall Support for the Remote Converter

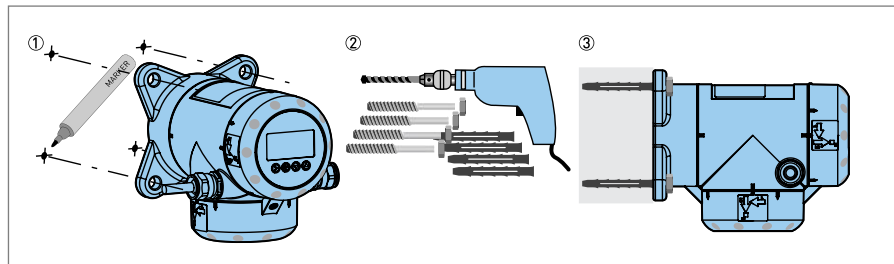

Fig 31: Wall support for the remote version (attached to the remote converter)

1. Use marks on the wall to help you put the wall support in the correct position.
2. Use equipment and tools that agree with health and safety regulations and good engineering practice.
3. Ensure the wall support is correctly attached to the wall.

3.3.10 Install Wall Supports for Devices with the Sensor Extension

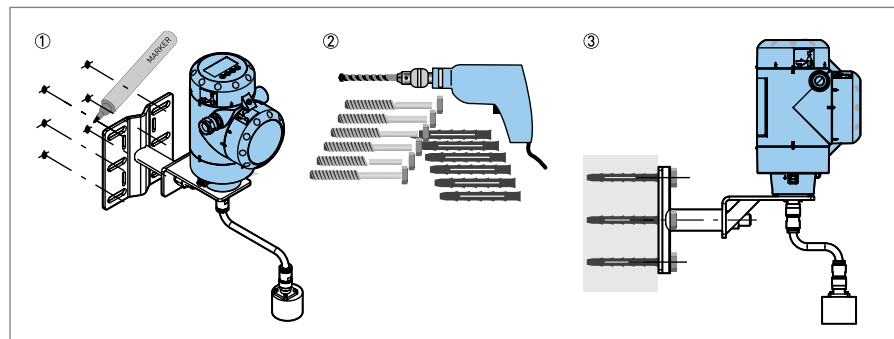

Fig 32: Wall Support for the Sensor Extension Part 1

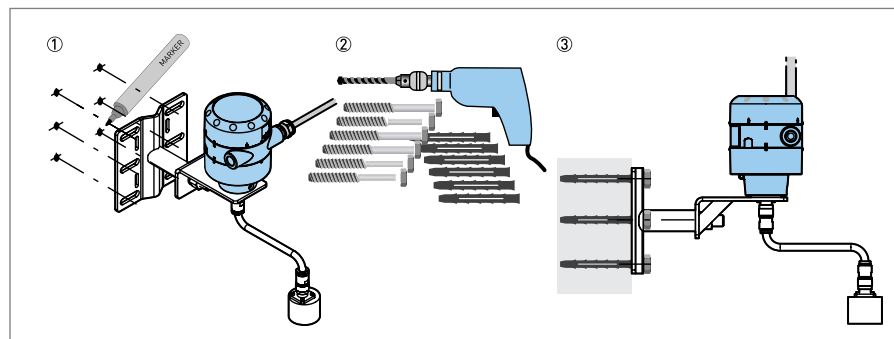

Fig 33: Wall Support for the Sensor Extension Part 2

1. Use marks on the wall to help you put the wall support in the correct position.
2. Use equipment and tools that concur with health and safety regulations and good engineering practice.
3. Ensure the wall support is correctly attached to the wall.

3.3.11 Attachment of Weather Protection to Device

The device and the weather protection option are supplied disassembled in the same box. The weather protection can also be supplied as an accessory. You must attach the weather protection when you install the device.

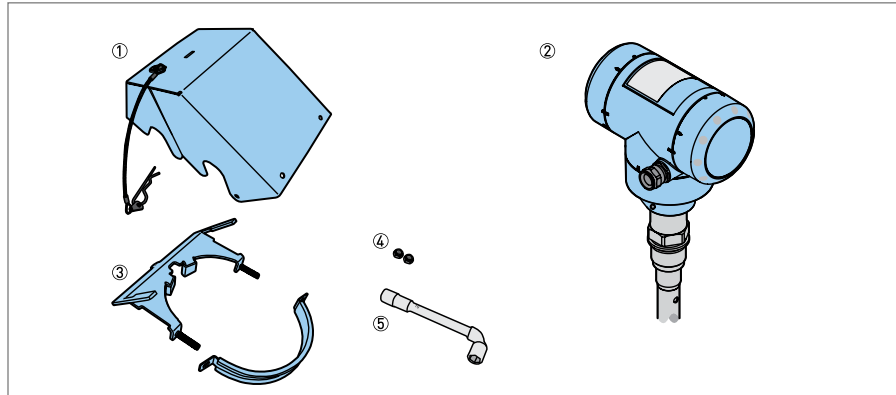

Fig 34: Equipment of Attachment Weather Protection to Device

1. Weather protection cover (with an R-clip to hold the cover on the clamp).
2. Device (with or without the optional display screen).
3. Weather protection clamp (2 parts).
4. 2 locking nuts.
5. 10mm socket wrench (not supplied).

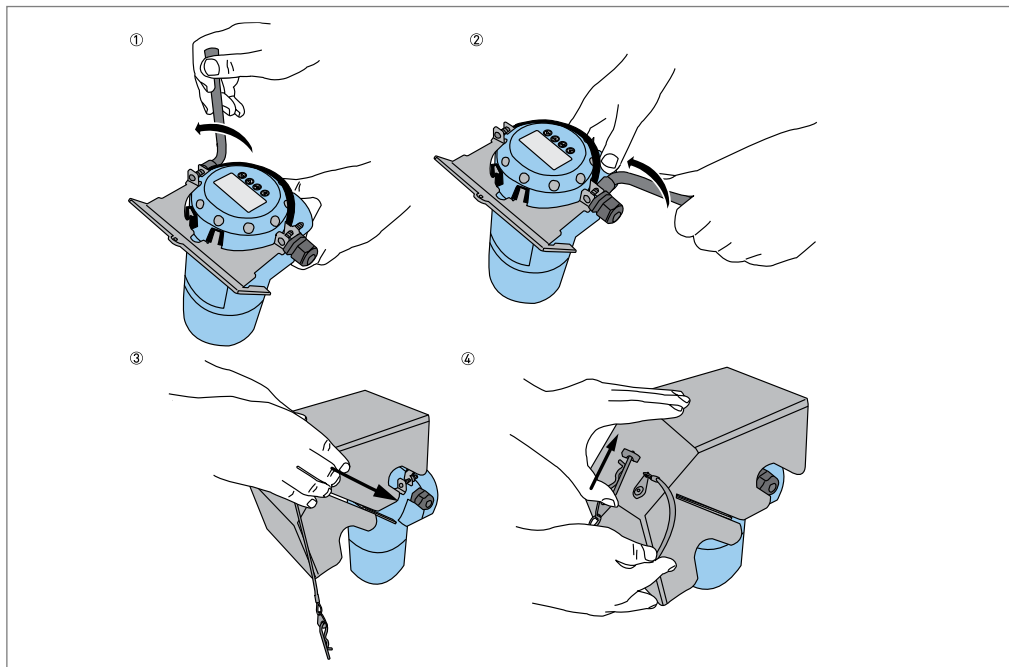

Fig 35: Installation of the Weather Protection on a Vertical Signal Converter

i NOTE

Install the weather protection after you connect the device to the power supply.

1. Place the weather protection clamp around the top of the device. Ensure the locking nuts on the clamp are aligned with the cable entries.
2. Attach the two locking nuts to the threads on the weather protection clamp. Tighten the locking nuts with a 10mm socket wrench.
3. Lower the weather protection cover onto weather protection clamp until the hole for the lock is in the slot at the front of the cover.
4. Put the R-clip into the hole at the front of the weather protection cover.

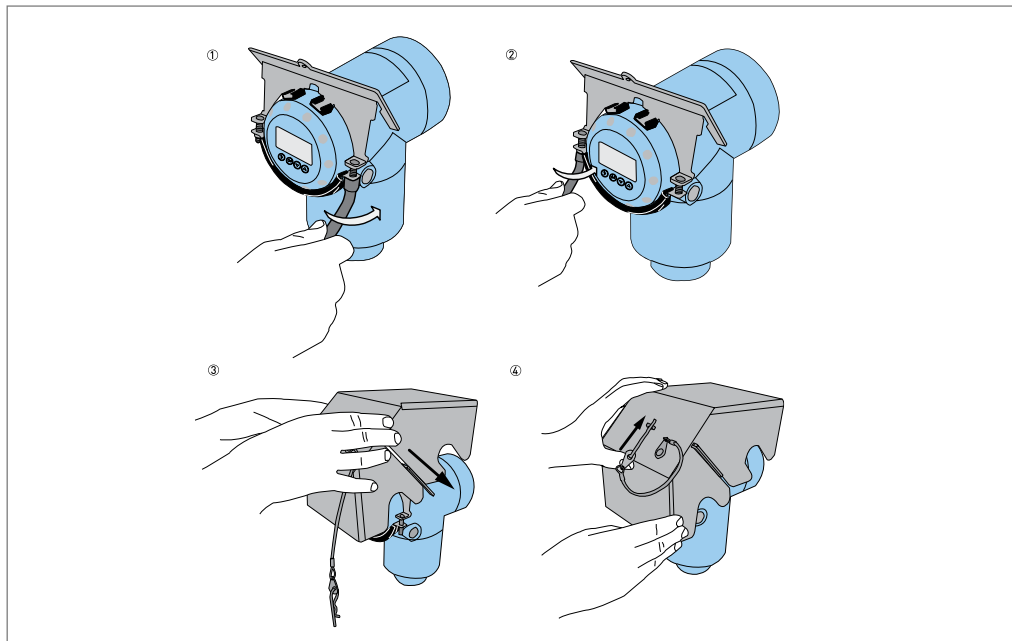

Fig 36: Installation of the Weather Protection on a Horizontal Signal Converter

i NOTE

Install the weather protection after you connect the device to the power supply.

1. Place the weather protection clamp around the front of the device (the end of the device that is nearest to the cable entry).
2. Attach the two locking nuts to the threads on the weather protection clamp. Tighten the locking nuts with a 10mm socket wrench.
3. Lower the weather protection cover onto weather protection clamp until the hole for the lock is in the slot at the front of the cover.
4. Put the R-clip into the hole at the front of the weather protection cover.

3.3.12 Weather Protection Opening Process

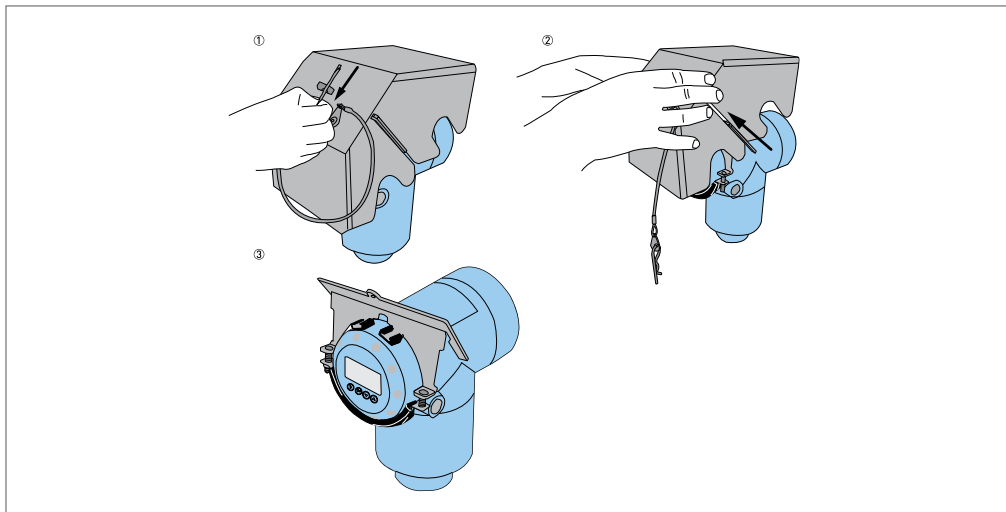

Fig 37: Process of Opening Weather Protection

i **NOTE**

Remove the weather protection before you open the terminal compartment cover.

1. Remove the R-clip from the hole at the front of the weather protection cover.
2. Remove the weather protection cover.

4 Electrical Connection

This section covers all electrical connection requirement. Electrical connection of the device must be carried out by trained, qualified specialists authorized to perform such work by the installation site.



WARNING

-
- Connect all electrical cables when the power is switched off. If the device does not have switch-off elements, then, overcurrent protection devices, lightning protection and/or energy isolating devices must be provided by the customer.
 - The device must be grounded to a spot in accordance with regulations in order to protect personnel against electric shocks.
-

i **NOTE**

When using the measuring device in hazardous areas, installation must comply with the corresponding national standards and regulations and the Safety Instructions or Installation or Control Drawings.

4.1 General Instructions

This section includes electrical connection data about devices with the 4 to 20mA output and HART® communication options, such as 2-wire, loop-powered devices.

4.2 2-Wire, Loop Powered

4.2.1 Compact and Remote Version



CAUTION

- Output 1 energizes the device and is used for HART® communication.
- If the device has the second current output option, use a separate power supply to energize output 2.
- If the device has a switch output - relay option, use a separate power supply (connect the power supply to the switch power supply terminals).

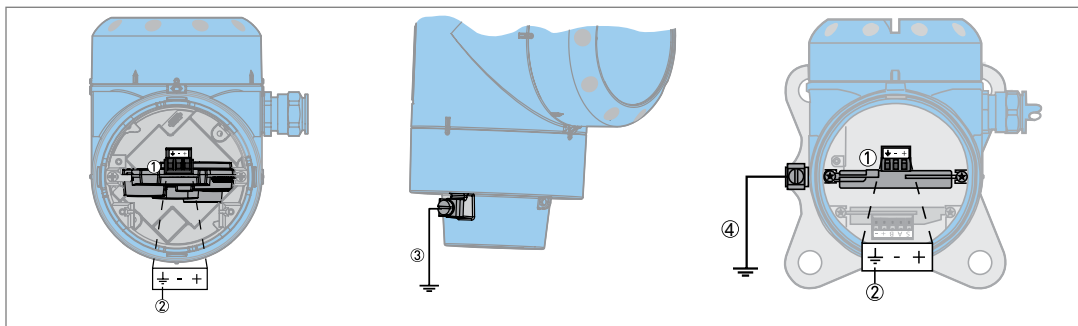

Fig 38: Electrical Installation Connection for Single Output Compact Version and remote version

1. Current output 1.
2. Grounding terminal in the housing (if the electrical cable is shielded).
3. Location of the external grounding terminal (at the bottom of the converter).
4. Location of the external grounding terminal (on the wall support).



CAUTION

- Use the applicable electrical cables with the cable glands.
- Ensure the current is not more than 4 A or that there is 4 A-rated fuse in the electrical circuit that energizes the device.
- Ensure the polarity of the power supply is correct. If the polarity is incorrect, you will not cause damage to the device, but the device will not operate.

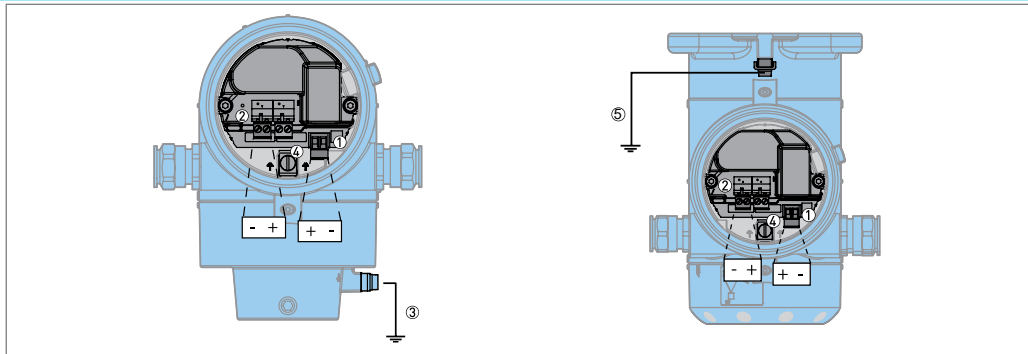

Fig 39: Electrical Installation Connection for Dual Outputs for Compact and Remote Version

1. Output 1: Terminals.
2. Output 2: Terminals.
3. Location of the external grounding terminal (at the bottom of the converter).
4. Grounding terminal in the housing (if the electrical cable is shielded).
5. Location of the external grounding terminal (on the wall support).



CAUTION

- Use the applicable electrical cables with the cable glands.
- Ensure the current is not more than 4 A or that there is 4 A-rated fuse in the electrical circuit that energizes the device.
- Ensure the polarity of the power supply is correct. If the polarity is incorrect, you will not cause damage to the device, but the device will not operate.

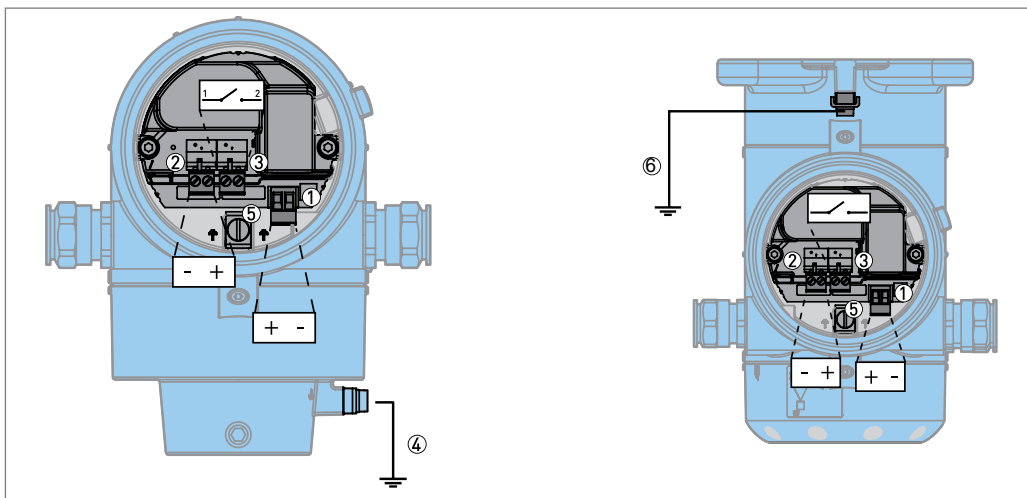

Fig 40: Electrical Connection of Single Current Output and Single Switch Output – Relay

1. Current output 1: Terminals.
2. Switch power supply: Terminals.
3. Switch output - relay: Terminals.
4. Location of the external grounding terminal (at the bottom of the converter).
5. Grounding terminal in the housing (if the electrical cable is shielded).
6. Location of the external grounding terminal (on the wall support).



CAUTION

- Use the applicable electrical cables with the cable glands.
- Current output: Ensure the current is not more than 4 A or that there is 4 A-rated fuse in the electrical circuit that energizes the device.
- Switch output - relay: Ensure the current is not more than 6 A or that there is 6 A rated fuse in the electrical circuit that energizes the device. (For Compact Version).
- Switch output - relay: Make sure that the current is not more than 5 A or that there is 5 A rated fuse in the electrical circuit that energizes the device. (For Remote Version)
- Ensure the polarity of the power supply is correct. If the polarity is incorrect, you will not cause damage to the device, but the device will not operate.

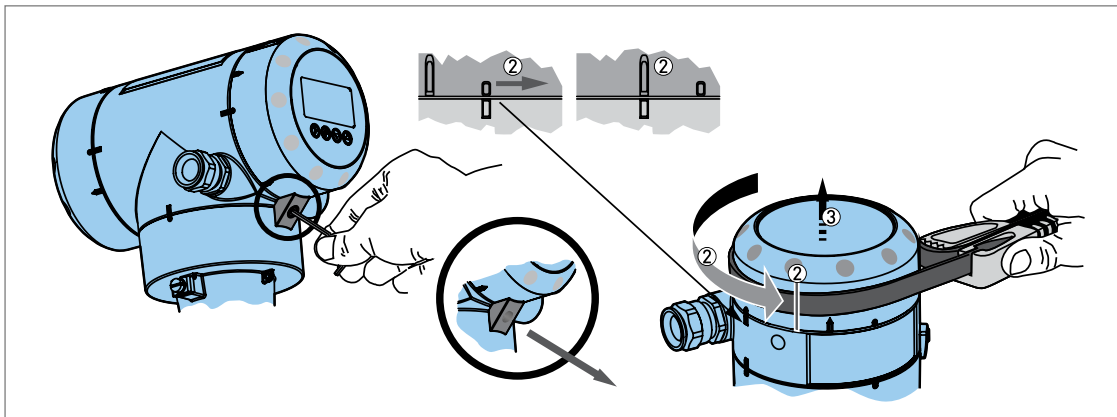

Fig 41: Open Terminal Compartment Cover for Single Output

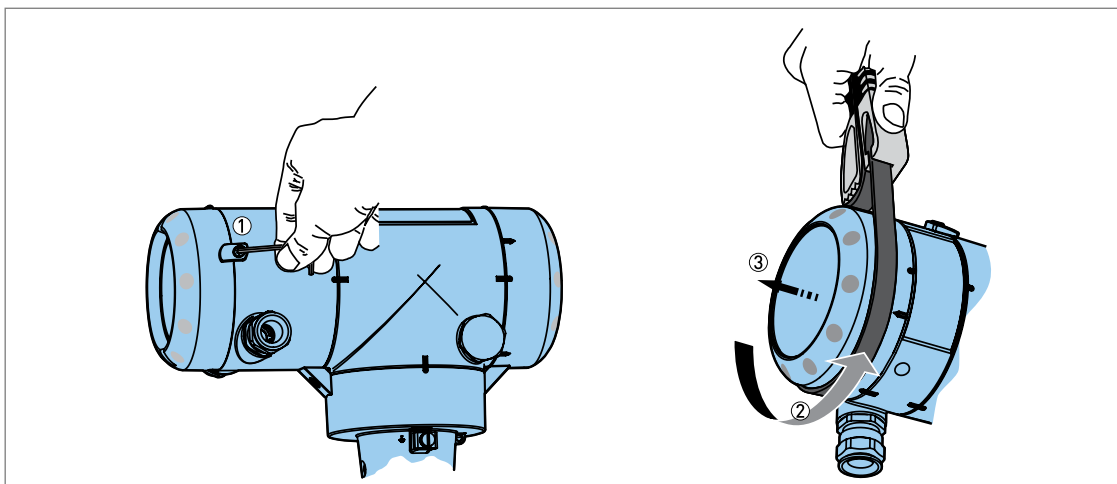

Fig 42: Open the Terminal Compartment Cover for Dual Output

1. Loosen the lock screw with a 2.5mm Allen wrench.
2. Turn the cover counter-clockwise with a strap wrench.
3. Remove the cover.

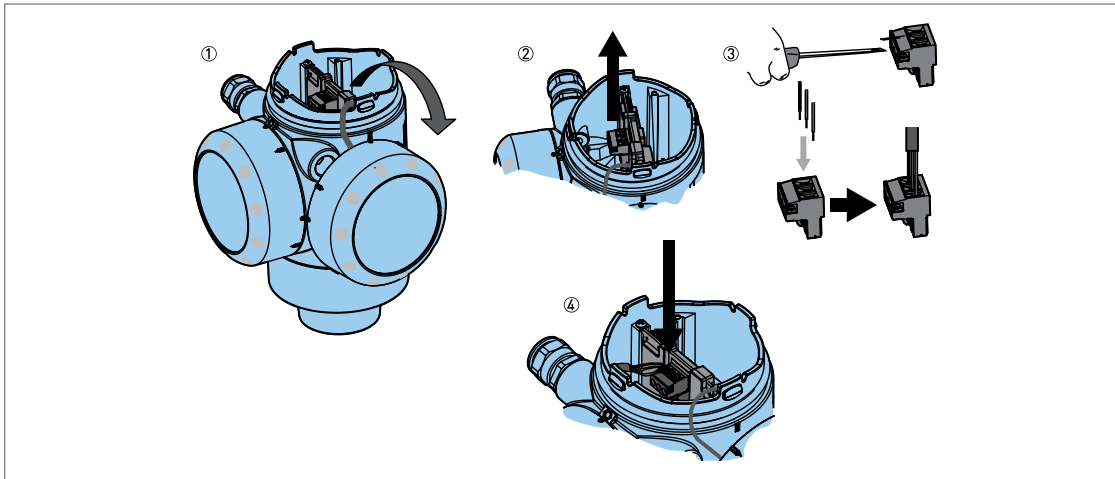

Fig 43: Electrical Installation Procedure for Single Output

- Required Equipments
 - Small, slotted tip screwdriver (not supplied)

 1. Do not disconnect the safety cord from the terminal compartment cover. Put the terminal compartment cover adjacent to the housing.
 2. Remove the connector from the circuit board.
 3. Connect the electrical wires to the connector.
 4. Attach the connector to the circuit board. Tighten the cable entry glands.

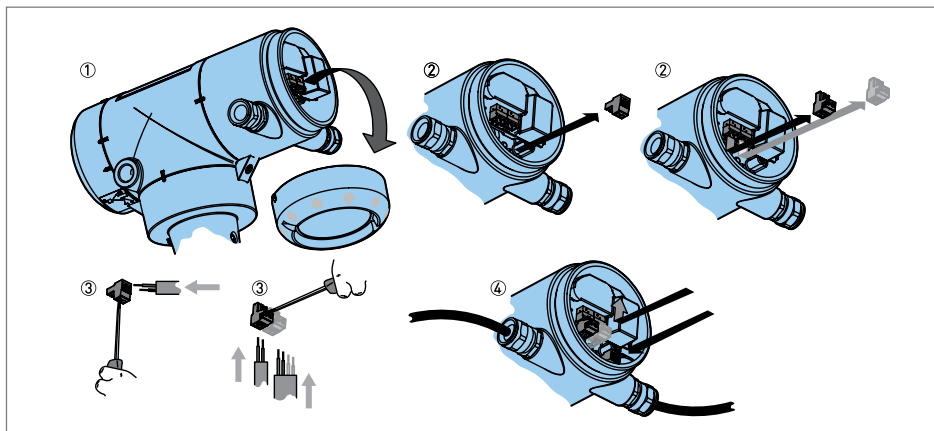

Fig 44: Electrical Installation Procedure for Dual Output

1. Put the terminal compartment cover adjacent to the housing.
2. Remove the connectors from the circuit board. If the device has the optional switch output, remove the connector for the switch output.
3. Put the electrical cables in the cable entries. Connect the electrical wires to the connectors. If the device has the optional switch output, use a 4-wire electrical cable for the switch power supply connector and the output connector.
4. Attach the connectors to the circuit board. Tighten the cable entry glands.

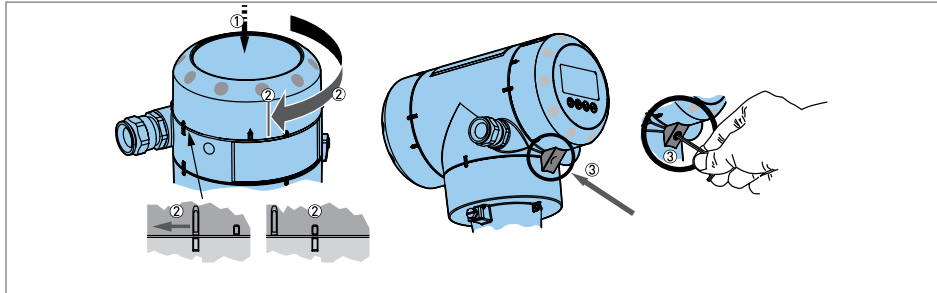

Fig 45: Close Terminal Compartment Cover for Single Output

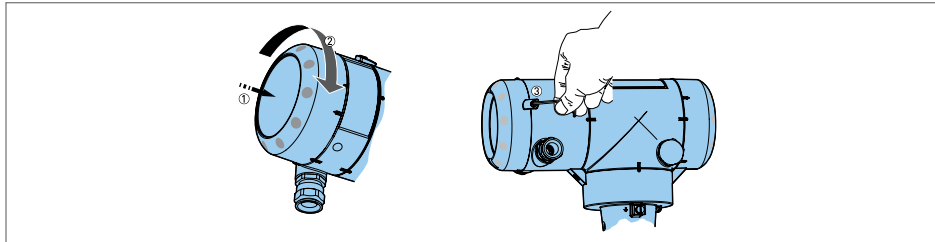

Fig 46: Close the Terminal Compartment Cover for Dual Output

1. Put the cover on the housing and push it down.
2. Turn the cover clockwise until it is fully engaged.
3. Tighten the lock screw.

4.3 Electrical Connection for Current Output

4.3.1 Non-Ex Device

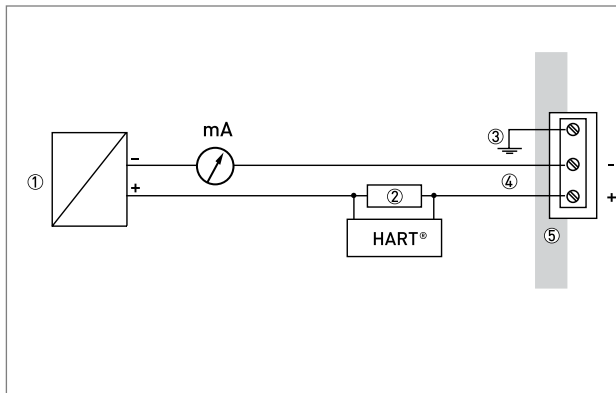

Fig 48: Electrical connections for non-Ex devices
(Single Current Output)

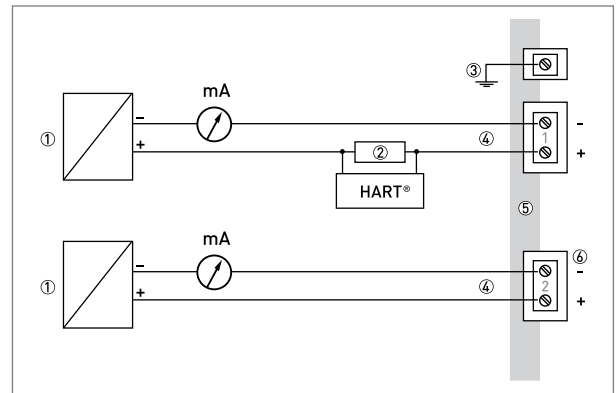

Fig 49: Electrical connections for non-Ex
devices (Dual Current Output)

1. Power supply.
2. Resistor for HART® communication.
3. Optional connection to the grounding terminal.
4. Output: 11.5 to 30 VDC for an output of 22mA at the terminal.
5. Device.
6. Connector for the optional second output.

*Note: Use a separate power supply to energize output 2.

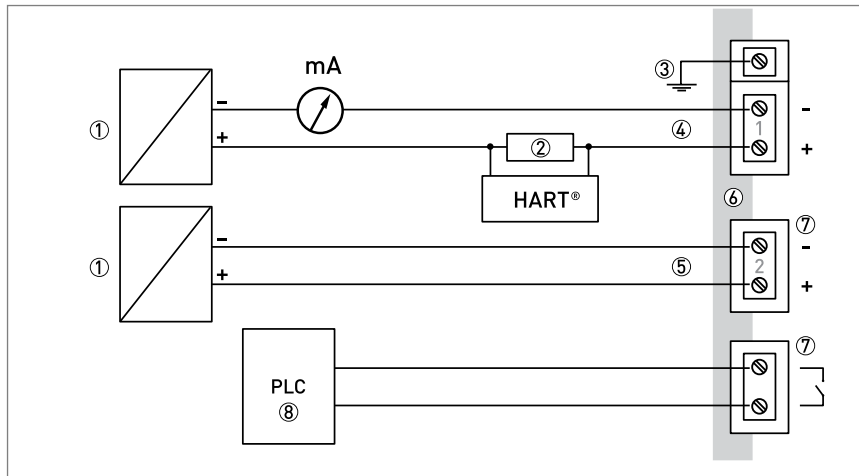

Fig 50: Electrical connections for non-Ex devices (Single current output and Single switch output - relay)

1. Power supply.
2. Resistor for HART® communication.
3. Optional connection to the grounding terminal.
4. Output: 11.5 to 30 VDC for an output of 22mA at the terminal.
5. Switch power supply (2): 11.5 to 34 VDC / 30mA.
6. Device.
7. Connector for the switch output – relay.
8. PLC (for example).

5 Operations

5.1 Digital Display Screen

5.1.1 Local Display Screen

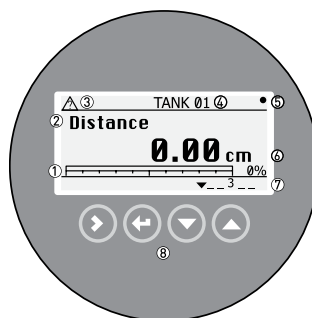

Fig 47: Local display screen layout in Normal mode

1. Current output percentage (bar graph and text shown if the current output function is the same as the measurement on the screen in normal mode).
2. Measurement type (in this example, distance).
3. Device status (NE 107 symbols).
4. Device tag name
5. Updated measurement data symbol (the symbol flashes each time the measurement data is updated).
6. Measurement value and units.

7. Device status (markers).
8. Keypad buttons (refer to the table in the section that follows).

The current output percentage is shown if the measurement type is the same as the output function. The parameter is set in menu section. For example, if the output function is set to "Level" and the device shows "Level" measurements in normal mode, the bar graph and value is shown in figure 47.



1. Function name
2. Configuration mode symbol
3. Menu number

Fig 48: Local display screen layout in configuration mode

5.2 Normal Mode

- Normal mode shows measurement data.
 - for the selection of the measurement type (distance, level, sensor temperature, converter temperature, output, percentage output, dielectric gas, dielectric product, and conversion).
 - for the selection of the measurement units.
- Some measurement types will only be available if the device has the correct parameters entered in the configuration mode.

i NOTE

- If you press a keypad button for less than 2 seconds, then you can use the standard function.
- If you press a keypad button for more than 2 seconds, then you can use the "Hot key" function.

Table 1: Keypad Function

Key	Description	Standard Function	"Hot Key" Function
	Right	Enter configuration mode	Software versions installed on the device (converter firmware version, sensor firmware version and the HMI (device display screen) firmware version).
	Return / Escape	Change the measurement units	Enter Auto Setup menu. Enter the supervisor password. You can set the time, date, probe length, tank height, tank type, application type, top product data, current output function, 4mA value and 20mA value.



	Down	Change the measurement type	Setup summary (output function, 4mA value, 20mA value and output range). Press [>] again and again to read the installation summary, application summary and probe summary. Press [▲] or [▼] to scroll up or down the list. Press [>] again to go back to normal mode.
	Up	Change the measurement type	Enter the display language menu. Enter the supervisor password. You can change the display screen language.

Table 2: Measurement Definition

Measurement Type	Description	Available units
LEVEL	This is a display and an output function option. It is the height from the bottom of the tank to the surface of the liquid contents (tank height - distance).	m, cm, mm, in (inches), ft (feet)
DISTANCE	This is a display and an output function option. It is the distance from the face of the flange to the surface of the liquid contents of the tank.	m, cm, mm, in (inches), ft (feet)
INTERFACE LEVEL	This is a display and an output function option. If the tank contains 2 liquids, it is the height from the bottom of the tank to the interface between the top liquid and the bottom liquid (tank height – interface distance).	m, cm, mm, in (inches), ft (feet)
INTERFACE DISTANCE	This is a display and an output function option. If the tank contains 2 liquids, is the distance from the face of the flange to the interface between the top liquid and the bottom liquid.	m, cm, mm, in (inches), ft (feet)
LAYER	This is a display and an output function option. If the tank contains 2 liquids, it gives the thickness of top product. The layer must be more than 50mm or 2" for accurate measurement of level and/or interface.	m, cm, mm, in (inches), ft (feet)
LAYER CONVERSION	This is a display and an output function option. It gives the volume or mass of the top liquid when there are 2 or more liquids in the tank. This data is available if you prepare a volume or mass table in configuration mode.	kg, t, Ston, Lton, m, cm, mm, in, ft, m ³ , L, gal, Imp, ft ³ , bbl, m ³ /h, ft ³ /h

SENSOR TEMPERATURE	This is a display and an output function option. The temperature of the sensor electronics.	°C, K, °F, °R
CONV. TEMPERATURE	This is a display and an output function option. The temperature in the signal converter housing.	°C, K, °F, °R
OUTPUT %	The percentage of the current output. 0% = 4mA. 100% = 20mA.	%
OUTPUT I	The current output of the device.	mA
DIELECTRIC GAS	This is a display and an output function option. The dielectric constant (ϵ_r) of the gas in the tank. This value is calculated automatically if the device has the Dynamic Gas-phase Compensation option. If this option does not show the message "Option is active", enter a code.	-
DIELECTRIC PRODUCT	This is a display and an output function option. The dielectric constant of the contents of the tank. An electrical property of the liquid contents of the tank. An electrical property of the product to be measured. Also known as ϵ_r , DK and relative permittivity. This can have an effect on the accuracy of the device.	-
DISTANCE CONVERSION	Distance conversion. This is a display and an output function option. It gives the empty volume or remaining mass that can be put in the tank. This data is available if you prepare a volume or mass table in configuration mode.	kg, t, Ston, Lton, m, cm, mm, in, ft, m ³ , L, gal, Imp, ft ³ , bbl, m ³ /h, ft ³ /h
CONVERSION	This is a display and an output function option. It gives the volume or mass of the tank contents. This data is available if you prepare a volume or mass table in configuration mode.	kg, t, Ston, Lton, m, cm, mm, in, ft, m ³ , L, gal, Imp, ft ³ , bbl, m ³ /h, ft ³ /h
RELAY STATE	This is a display and an output function option. This gives the condition of the relay function, if the output function of the optional second output is set to "RELAY".	Open, Closed
TIME	This is a display option. The time format and the time can be set in the Auto Setup procedure and Supervisor menu.	-

DATE	This is a display option. The date format and the date can be set in the Auto Setup procedure and Supervisor menu.	-
------	--	---

5.3 Configuration Mode

5.3.1 General Instruction

Change the settings of your device in Configuration mode. Data about the menu is given. You can:

- Use the Auto Setup menu to commission the device and set basic parameters [tank height etc.]
- Use the Advanced Setup menu to commission the device for use in difficult conditions.
- Use the Supervisor menu to commission the device, to run diagnostic tests, set up a conversion table for volume or mass measurement, change output settings, enter a tag name, change output mode, change critical parameters for difficult process conditions, reset the device and change basic parameters [tank height, output settings, polling address etc].



CAUTION

The Auto Setup procedure is mandatory.

5.3.2 Access to the Auto Setup Procedure

- Press the [↵] button for more than two seconds.
 - The screen shows a line. You must enter the password. Press the buttons under the display screen 6 times (in total and in a given order) to get access to Configuration mode.
- Type in the password. The factory-set password is [>], [↵], [▼], [▲], [>] and [↵].
- Press the [>] button [YES] to start the Auto Setup procedure.
- Press the [▲] button one time to scroll up to the Supervisor menu.

5.3.3 Menu Overview

Table 3: 1.0.0 Advanced Setup

1.1.0	Installation Setup
1.1.1	Conversion Setup
1.1.2	Application Setup
1.1.3	Options Setup
1.1.4	Maintenance Setup

Table 4: 2.0.0 Supervisor

2.1.0	Identification
2.1.1	Tests
2.1.2	Basic Parameters
2.1.3	Output
2.1.4	Application

2.1.5	Communication
2.1.6	Display
2.1.7	Conversion Table
2.1.8	Reset
2.1.9	History

Table 5: Service

NA	Password locked. Menus for factory calibration and qualified service personnel only
----	---

Table 6: Master

NA	Password locked. Menus for factory calibration and qualified service personnel only
----	---

i NOTE

Press the [←] button for more than two seconds in normal mode to start the procedure.

5.3.4 Keypad Functions

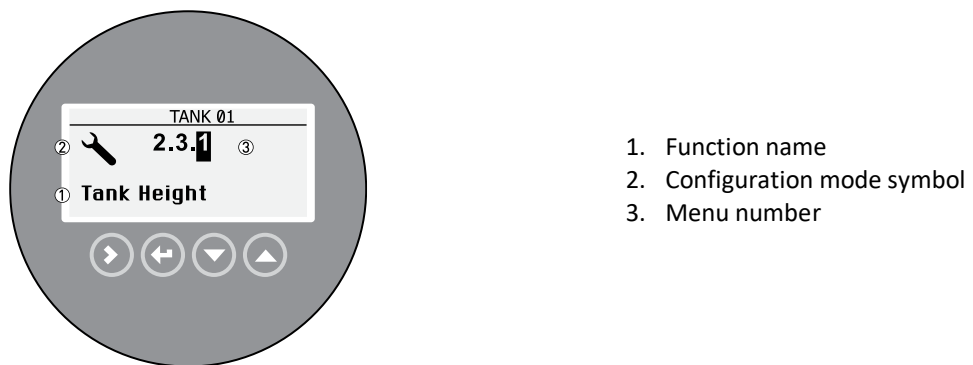
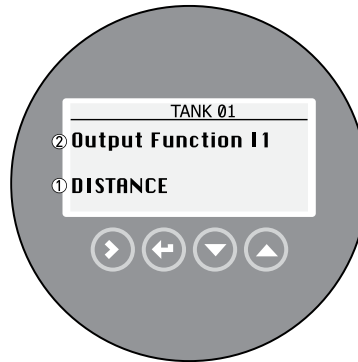

Fig 49: Local Display Screen Layout in Configuration Mode

Table 7: Functions of Buttons for Menu Navigation

Key	Description	Function
	Right	<ul style="list-style-type: none"> Go down to the sub-menu level (for example, from menu 1.0.0 to sub-menu 1.1.0). Enter the menu item.
	Enter or Escape	<ul style="list-style-type: none"> Go up to the menu level [for example, from sub-menu 1.1.0 to menu 1.0.0). Go to Normal mode. If you changed settings in Configuration mode, you must save or cancel your new settings. For more data, refer to the end of this section.
	Down	<ul style="list-style-type: none"> Scroll down the menu list {for example, from menu 2.0.0 to menu 1.0.0). Scroll down the sub-menu list [for example, from sub-menu 2.2.0 to sub-menu 2.1.0).

	Up	<ul style="list-style-type: none"> • Scroll up the menu list! for example, from menu 1.0.0 to menu 2.0.0). • Scroll up the sub-menu list [for example, from sub-menu 2.1.0 to sub-menu 2.2.0).
--	----	--



1. Parameter
2. Menu number

Fig 50: Parameter Menu

Table 8: List of Parameters

Key	Description	Function
	Right	NA
	Enter or Escape	Select the parameter and go back to the menu
	Down	Move down the list
	Up	Move up the list

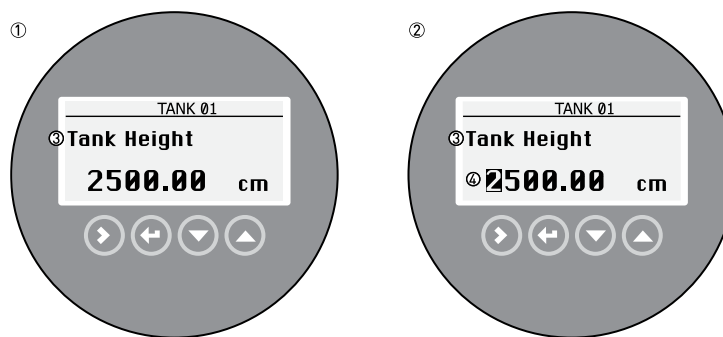





Fig 51: Values in menu items

1. Menu item with values stored at this time (first screen)
2. Press [>] again to change the values. A cursor shows on the first digit.
3. Menu item name
4. Cursor on the selected digit

Table 9: Values in Menu and its function

Key	Description	Function
	Right	<ul style="list-style-type: none"> Enter the menu item and see the value stored at this time. Enter the menu item configuration level to change the value. Move the cursor to the next digit on the right. If the cursor is on the last digit, press [>] again to go back to the first digit.
	Enter or Escape	Accept the value and go back to the sub-menu.
	Down	Decrease the digit value.
	Up	Increase the digit value,

- Settings of the advanced setup menu [menu 1.0.0) and the supervisor menu [menu 2.0.0):
 - When you have changed parameters in all the necessary menu section, press [↵] to accept the new parameter.
 - Press [↵] to go back to the "STORE" screen.
 - The device will ask you to save or cancel your settings. Press [▲] or [▼] to select STORE YES or STORE NO. Press [↵] to accept or reject the new settings.
 - The display goes back to Normal mode.

5.3.5 Function Description

- Auto Setup procedure

Auto Setup procedure is available in measurement mode. Press the [↵] button for more than 3 seconds to start the Auto Setup procedure. Enter the Supervisor password.

This procedure is applicable to most applications.



CAUTION

Ensure you do the Auto Setup procedure before you use the device. The settings in this procedure have an effect on the performance of the device.

Use the Auto Setup menu to commission the device. Follow the procedure and give the correct values for each step. You must do this procedure before the device starts to measure the level of the product. At the end of the procedure the device will do a series of checks identification of the process connection (flange analysis) and probe signals (probe analysis). It will also do a scan for interference signals along the probe.

Table 10: Auto Setup Function and its Description

Function	Function Description	Selection List or Range of Values	Default
Date/Clock format		YYYY/MM/DD 24h, DD/MM/YYYY 12h, DD/MM/YYYY 24h, YYYY/MM/DD 12h	DD/MM/YYYY 24h
Set Clock	Give the time. If the device stays de-energized for more than two weeks, it will be necessary to set the time and date again.	-	-
Set Date	Give the date. If the device stays de-energized for more than two weeks, it will be necessary to set the time and date again.		
Probe Length	Probe length is the distance from the flange face l thread stop of the device down to the bottom end of the probe including counterweight for cable versions). If you changed the probe length, enter the new value here.	min: 2.3.2 Blocking Distance + 3.1.1 Counterweight max: Probe length depends on the measuring range for each type of probe.	This value is given in the customer order.
Installation Type	The conditions in which the device is used. If the device is installed on a tank, set this step to "TANK". If the device is installed in a stilling well or bypass chamber, set this step to "STILLING WELL / BYPASS".	TANK, STILLING WELL/ BYPASS	TANK
Tank Height	The distance from the tank connecting flange face / thread stop down to the tank bottom. If Installation Type is set to "STILLING WELL/ BYPASS", Tank Height is replaced by two steps: Stilling Well Height and Internal Diameter.	min-max: 0.0 to 99999mm	Probe length or value specified by the customer
Stilling Well Height	The distance from the tank connecting flange Height face / thread stop down to the bottom of the stilling well or the bottom process connection of the bypass chamber. This function replaces Tank Height. It is available if Installation Type is set to "STILLING WELL / BYPASS".	min-max: 0.0 to 99999mm	Probe length or value specified by the customer
Internal Diameter	The internal diameter of the stilling well or bypass chamber. It is available if Installation Type is set to "STILLING WELL/ BYPASS".	min-max: 40 to 1000mm	200mm
Application Type	This function tells the device what to look for in the tank and what to do with the measurement signals. If the device has the Dynamic Gas-phase Compensation [DGC] option, the device will do a process analysis to measure the dielectric constant of the gas above the product in the tank.	LEVEL, LEVEL+ INTERFACE MIXED, LEVEL+ INTERFACE UNMIXED, INTERFACE [FULLY SUBMERGED PROBE). LEVEL WITH GAS PHASE COMPENSATION, INTERFACE WITH REVERSED PROBE	LEVEL
Epsilon R Product	This is the dielectric constant of the top product. If Epsilon R Product is "Known"	Known, Unknown min-max: 1 to 115	2.5
	If Epsilon R Product is "Unknown". What is the product family?	ACIDS, ALCOHOL, BASE, HYDROCARBON, LIQUID GAS, MINERAL OIL, SOLVENT, WATER-BASED, OTHER	OTHER

Output Function I1	The output function for output 1. Make a I1 selection from a list of output functions to scale the current values in relation to a given point [usually the device process connection or the tank bottom). The output current value is shown on a bar graph in normal mode if the measurement name (displayed measurement) is the same as the output function. Conversion parameters (DISTANCE CONV., LEVEL CONVERSION etc.) are shown if there is volume or mass data in menu item 1 .2.0 Conversion Setup.	LEVEL, LEVEL CONVERSION, DISTANCE, DISTANCE CONV., INTERFACE LEVEL, INTERFACE CONVERSION, INTERFACE DISTANCE, INTERFACE DIST. CONV., LAYER, LAYER CONVERSION, DIELECTRIC PRODUCT, DIELECTRIC GAS, CONVERTER TEMPERATURE, SENSOR TEMPERATURE (1)	LEVEL
Scale 4mA I1	This function gives a measurement value to 4mA (output 1).	min-max: (2)	(3)
Scale 4mA I1	This function gives a measurement value to 20mA (output 1).	min-max (2)	(3)
Optional Output mode	This function operates the optional second output (output 2). If you set this function to "CURRENT", the second output supplies 4 to 20mA. Give the settings for this current output in Output Function 12, Scale 4mA 12 and Scale 20mA 12. If you set this function to "RELAY", the second output supplies a switch signal. Give the settings for this relay signal in Switch Function, Set Point/Threshold, Alarm Mode and Hysteresis. If Switch Function is set to "ERROR UST", set a condition in Error List only.	DISABLE, CURRENT, RELAY (4)	(3)
Output Function I2	The output function for output 2. Make a I2 selection from a list of output functions to scale the current values in relation to a given point [usually the device process connection or the tank bottom). The output current value is shown on a bar graph in normal mode if the measurement name (displayed measurement) is the same as the output function. Conversion parameters (DISTANCE CONV., LEVEL CONVERSION etc.) are shown if there is volume or mass data in menu item 1 .2.0 Conversion Setup. This function is available if Optional Output Mode is set to "CURRENT".	LEVEL, LEVEL CONVERSION, DISTANCE, DISTANCE CONV., INTERFACE LEVEL, INTERFACE CONVERSION, INTERFACE DISTANCE, INTERFACE DIST. CONV., LAYER, LAYER CONVERSION, DIELECTRIC PRODUCT, DIELECTRIC GAS, CONVERTER TEMPERATURE, SENSOR TEMPERATURE (1)	Distance
Scale 4mA I2	This function gives a measurement value to 4mA (output 2). This function is available if Optional Output Mode is set to "CURRENT".	min-max: (2)	(3)
Scale 4mA I2	This function gives a measurement value to 20mA (output 2). This function is available if Optional Output Mode is set to "CURRENT".	min-max (2)	(3)
Switch Function	The switch function for output 2. Select from a list of switch functions to set the switch signal to the function that the device must monitor. For more data about the switch function, refer to Relay output.	LEVEL, LEVEL CONVERSION, DISTANCE, DISTANCE CONV., INTERFACE LEVEL, INTERFACE CONVERSION, INTERFACE DISTANCE, INTERFACE DIST. CONV.,	

		LAYER, LAYER CONVERSION, DIELECTRIC PRODUCT, DIELECTRIC GAS, CONVERTER TEMPERATURE, SENSOR TEMPERATURE, CURRENT mA, CURRENT%, ERROR LIST (1)	
Set Point/Threshold	This function gives the point or threshold (level, distance etc) when the device will send the relay signal. This function is available if Optional Output Mode is set to "RELAY" and Switch Function is not set to "ERROR LIST".	min-max: @	-
Alarm Mode	"LOW LEVEL ALARM" tells the device to send the relay signal when the quantity of product in the tank is less than the threshold. "HIGH LEVEL ALARM" tells the device to send the relay signal when the quantity of product in the tank is more than the threshold. This function is available if Optional Output Mode is set to "RELAY" and Switch Function is not set to "ERROR LIST".	LOW LEVEL ALARM, HIGH LEVEL ALARM	-
Hysteresis	If Alarm Mode is set to "LOW LEVEL ALARM", this gives the quantity of product above the threshold where the relay goes back to "off" If Alarm Mode is set to "HIGH LEVEL ALARM", this gives the quantity of product below the threshold where the relay goes back to "off" This function is available if Optional Output Mode is set to "RELAY" and Switch Function is not set to "ERROR LIST".	min-max: (2)	-
Error List	If Switch Function is set to "ERROR LIST", Error List replaces the Point/Threshold, Alarm Mode and Hysteresis steps in this procedure. This tells the device to send a relay signal ii the error condition specified in this step occurs.	OVERFILL, TANK EMPTY, INTERFACE LOST, CONV. TEMP. < MINI, CONV. TEMP. > MAXI, SNSR. TEMP. < MIINI. SNSR. TEMP. > MAXI, DIELCT. CALC. FROZ., LEVEL LOST	-
Process analysis	The device automatically does this step.		
Is your tank partially filled or empty?	It is necessary to give this data to tell the device where to do a scan for interference signals along the probe (snapshot). If the tank is empty, select "Empty". The device does a scan to the end of the probe. If the tank is partially filled, select "Partially". The device goes immediately to the "Snapshot" step. The device does a scan. If the device detects an object or the surface of the measured product, you will see a measurement value and a message: Is it the product distance? If it is the correct distance to the surface of the product, Press the keypad I button for "Yes". If it is not the correct distance to the surface of the product (e.g., an interference signal), Press the keypad button for "No". We recommend that the tank is empty when you do the scan.	Partially, Empty	-

Probe analysis	The device automatically does this step.		
Flange analysis	The device automatically does this step if the gas phase compensation mode is set to "on".		
Snapshot	The device automatically does this step.		
Store Configuration	The display screen shows the summary of the Auto Setup procedure. Press a button to confirm the settings.		

*Note:

1. "INTERFACE LEVEL", "INTERFACE CONVERSION", "INTERFACE DISTANCE", "INTERFACE DIST. CONV.", "LAYER" and "LAYER CONVERSION" are only available if you set application type to "LEVEL+ INTERFACE MIXED", "LEVEL + INTERFACE UNMIXED" or "INTERFACE (FULLY SUBMERGED PROBE)". "LEVEL CONVERSION", "DISTANCE CONY.", "INTERFACE CONVERSION", "INTERFACE DIST. CONV.," and "LAYER CONVERSION" are only available if you made a conversion table (strapping table).
2. Units and range depend on the output function, length unit and volume unit selected.
3. This depends on the data given in the customer order.
4. "CURRENT" and "RELAY" are only available if a second output option is in the customer order.

- **Advanced Setup**

The Advanced Setup menu is a list of procedures that have more functions than the Auto Setup procedure. Press the [>] to go to Configuration mode. Enter the Supervisor password.

Table 11: Advanced Setup

Menu No.	Function	Function Description	Selection List or Range of Values	Default
1.1.0 Installation Setup				
		This starts a quick setup procedure to give the device data about the tank. This data includes installation type and tank height. If the device is installed in stilling well or a bypass chamber, give the height and the internal diameter of the chamber.		
	Installation Type	The conditions in which the device is used. If the device is installed on a tank, set this step to ""TANK"". If the device is installed in a stilling well or bypass chamber, set this step to ""STILLING WELL/ BYPASS"".	TANK, STILLING WELL/ BYPASS	TANK
	Tank Height	The distance from the tank connecting min-max: Probe length or flange face / thread stop down to the tank 0.0 to 99999mm value specified bottom. by the customer If Installation Type is set to ""STILLING WELL / BYPASS ", Tank Height is replaced by two steps: Stilling Well Height and Internal Diameter.	min-max: 0.0 to 99999mm	Probe length or value
	Stilling Well Height	The distance from the tank connecting flange Height face / thread stop down to the bottom of the stilling well or the bottom process connection of the bypass chamber. This function replaces Tank Height. It is available if Installation Type is set to "STILLING WELL / BYPASS".	min-max: 0.0 to 99999mm	Probe length or value
	Internal Diameter	The internal diameter of the stilling well or bypass chamber. It is available if Installation Type is set to "STILLING WELL/ BYPASS".	min-max: 40 to 1000mm	200mm
1.2.0 Conversion Setup				

	<p>Use this quick setup procedure to make a conversion table [strapping table] to measure volume or mass. The device uses a conversion table [strapping table] to convert measurements to volume and mass readings. The readings are shown in normal mode. Go to this menu item and give the length unit and then the conversion unit. Press the [>] button to enter the first level-conversion values. Then [>] again to enter the next point. Continue the procedure until the device has data for all the entries</p>			
1.3.0 Device Setup				
Use this quick setup procedure to give settings for output 1 and output 2				
1.3.1	Output I1 Setup	Use this quick set-up procedure to give the settings for the current output of output 1. These settings include the output function, output range, 4mA setting, 20mA setting, output error delay and the tag name.		
	Output Function I1	<p>The output function for output 1. Make a I1 selection from a list of output functions to scale the current values in relation to a given point [usually the device process connection or the tank bottom). The output current value is shown on a bar graph in normal mode if the</p>	Output Function I1	<p>The output function for output 1. Make a I1 selection from a list of output functions to scale the current values in relation to a given point [usually the device process connection or the tank bottom). The output current value is shown on a bar graph in normal mode if the</p>
	Output Range I1	<p>This menu item sets the limits of the output current range to 1 of the 2 available options: standard limits (4 to 20mA) or NAMUR NE 43-compliant limits (3.8 to 20.5mA). It also tells the device what to do if an error occurs. If you set Output Range 11 to and an error occurs (e.g., the tank is too full etc), the device output current will change to an error value of 22mA. If you set Output Range I1 to "4-20/3.6E" and an error occurs (e.g., the tank is empty etc.), the device output current will change to an error value of 3.6mA. If you set Output ' Range I1 to "4-20/HOLD" and the device senses a measurement error, the value will stop at the last correct measurement.</p>	4-20/3.6E, 3.8-20.5/22E, 4-20/3.6E, 3.8-20.5/3.6E, 4-20/HOLD, 4-20/22E	"4-20/22E"
	Scale 4mA I1	This function gives a measurement value to 4mA (output 1).	min-max: (2)	(3)
	Scale 4mA I1	This function gives a measurement value to 20mA (output 1).	min-max (2)	(3)

	Output Error Delay	The time after which the current output changes to an error value. The error value shows that there is a measurement error. MN=minutes and S=seconds.	0 S, 10 S, 20 S, 30 S, 1 MN, 2 MN, 5 MN, 15 MN	10 S
	Tag Name	The device has a code (tag name) to identify it. If the tag name is given in the customer order data, it will be set at the factory. A maximum of 8 characters can be used.		TANK 01
1.3.2	Output I2 Setup	Use this quick set-up procedure to give the settings for optional output 2.		
1.3.2	Optional Output mode	This function operates the optional second output (output 2). If you set this function to "CURRENT", the second output supplies 4 to 20mA. Give the settings for this current output in Output Function 12, Scale 4mA 12 and Scale 20mA 12. If you set this function to "RELAY", the second output supplies a switch signal. Give the settings for this relay signal in Switch Function, Set Point/Threshold, Alarm Mode and Hysteresis. If Switch Function is set to "ERROR UST", set a condition in Error List only.	DISABLE, CURRENT, RELAY (4)	(3)
1.3.2	Output Function I2	The output function for output 2. Make a I2 selection from a list of output functions to scale the current values in relation to a given point [usually the device process connection or the tank bottom). The output current value is shown on a bar graph in normal mode if the measurement name (displayed measurement) is the same as the output function. Conversion parameters (DISTANCE CONV., LEVEL CONVERSION etc.) are shown if there is volume or mass data in menu item 1.2.0 Conversion Setup. This function is available if Optional Output Mode is set to "CURRENT".	LEVEL, LEVEL CONVERSION, DISTANCE, DISTANCE CONV., INTERFACE LEVEL, INTERFACE CONVERSION, INTERFACE DISTANCE, INTERFACE DIST. CONV., LAYER, LAYER CONVERSION, DIELECTRIC PRODUCT, DIELECTRIC GAS, CONVERTER TEMPERATURE, SENSOR TEMPERATURE (1)	Distance
	Scale 4mA I2	This function gives a measurement value to 4mA (output 2). This function is available if Optional Output Mode is set to "CURRENT".	min-max: (2)	(3)
	Scale 4mA I2	This function gives a measurement value to 20mA (output 2). This function is available if Optional Output Mode is set to "CURRENT".	min-max (2)	(3)
	Switch Function	The switch function for output 2. Select from a list of switch functions to set the switch signal to the function that the device must monitor. For more data about the switch function, refer to Relay output.	LEVEL, LEVEL CONVERSION, DISTANCE, DISTANCE CONV., INTERFACE LEVEL, INTERFACE	LEVEL

			CONVERSION, INTERFACE DISTANCE, INTERFACE DIST. CONV., LAYER, LAYER CONVERSION, DIELECTRIC PRODUCT, DIELECTRIC GAS, CONVERTER TEMPERATURE, SENSOR TEMPERATURE, CURRENT mA, CURRENT%, ERROR LIST (1)	
	Set Point/Threshold	This function gives the point or threshold (level, distance etc) when the device will send the relay signal. This function is available if Optional Output Mode is set to "RELAY" and Switch Function is not set to "ERROR LIST".	min-max: @	-
	Hysteresis	If Alarm Mode is set to "LOW LEVEL ALARM", this gives the quantity of product above the threshold where the relay goes back to "off" If Alarm Mode is set to "HIGH LEVEL ALARM", this gives the quantity of product below the threshold where the relay goes back to "off" This function is available if Optional Output Mode is set to "RELAY" and Switch Function is not set to "ERROR LIST".	min-max: (2)	-
	Alarm Mode	"LOW LEVEL ALARM" tells the device to send the relay signal when the quantity of product in the tank is less than the threshold. "HIGH LEVEL ALARM" tells the device to send the relay signal when the quantity of product in the tank is more than the threshold. This function is available if Optional Output Mode is set to "RELAY" and Switch Function is not set to "ERROR LIST".	LOW LEVEL ALARM, HIGH LEVEL ALARM	-
	Error List	If Switch Function is set to "ERROR LIST", Error List replaces the Point/Threshold, Alarm Mode and Hysteresis steps in this procedure. This tells the device to send a relay signal if the error condition specified in this step occurs.	OVERFILL, TANK EMPTY, INTERFACE LOST, CONV. TEMP. < MINI, CONV. TEMP. > MAXI, SNSR. TEMP. < MINI. SNSR. TEMP. > MAXI, DIELECT. CALC. FROZ., LEVEL LOST	-
1.4.0 Application Setup				
	Use this quick set-up procedure to give the settings about the application type and the dielectric constant of the top product.			

	Application Type	This function tells the device what to look for in the tank and what to do with the measurement signals. If the device has the Dynamic Gas-phase Compensation [DGC] option, the device will do a process analysis to measure the dielectric constant of the gas above the product in the tank.	LEVEL, LEVEL+ INTERFACE MIXED, LEVEL+ INTERFACE UNMIXED, INTERFACE [FULLY SUBMERGED PROBE). LEVEL WITH GAS PHASE COMPENSATION, INTERFACE WITH REVERSED PROBE	LEVEL
	Epsilon R Product	This is the dielectric constant of the top product.	Known, Unknown	
		If Epsilon R Product is "Known"	min-max: 1 to 115	2.5
		If Epsilon R Product is "Unknown". What is the product family?	ACIDS, ALCOHOL, BASE, HYDROCARBON, LIQUID GAS, MINERAL OIL, SOLVENT, WATER-BASED, OTHER	OTHER
1.5.0 Options				
	Options can be included in the customer order or you can buy this option after delivery. For more data, speak or write to your supplier.			
1.5.1	Interface	This option is in operation.		
	Gas Phase Comp.	A device option. This function shows if the Dynamic Gas-phase compensation (OGG) mode is set to on (the menu item shows the message "option is active "). You can set the OGG mode to on if you enter a code in this menu item. If you do not have this code, contact your supplier to buy this option.		
1.6.0 Maintenance Setup				
	Converter Type	The signal converter is available in 4 versions. Select from the list. If you set Converter Type to "S: SENSOR EXTENSION., or "D: DOUBLE SENS. EXT.", then you must also enter the sensor extension length.	C: COMPACT, F: REMOTE VERSION, S: SENSOR EXTENSION, D: DOUBLE SENS. EXT.	(3)
	Remote Cable Length	The length of the sensor extension. If the device is the "Sensor extension with compact version (S)", this is the coaxial cable between the converter and the process connection. If the device is the "Double sensor extension with remote version (D)", this is the coaxial cable between the probe electronics housing and the process connection.	0 to 15 m	(3)
	Process Type	The process seal option for the device.	STANDARD LIQUID THREADED. STANDARD LIQUID FLANGE, CERAMIC HT	(3)

			<p>THREADED, CERAMIC HT FLANGE, OTHER PROCESS</p>	
	<p>Probe Type</p>	<p>The probe option for the device. If the measurement screen is set to SI units, then probe dimensions are given in millimetres. If the measurement screen is set to Imperial / US Customary units, then probe dimensions are given in inches.</p>	<p>SI units: OTHER PROBE, SINGLE ROD 08, SINGLE ROD 08 COATED, DOUBLE ROD 08, COAX 022, COAX 022 ADAPTED, COAX 042, CABLE 04 C/W 20x100, CABLE 04 + TURNBUCKLE. CABLE 04 + CHUCK, CABLE 04 + THREADED END, CABLE 04 CRIMPED END, CABLE 04 OPEN END, CABLE 04 C/W 20x100 COATED, CABLE 04 C/W 60x20, DOUBLE CABLE 04 C/W 38x60, REVERSED PROBE Imperial/ US Customary units: OTHER PROBE, SINGLE ROD 00.3T, SINGLE ROD 00.3T COATED, DOUBLE ROD 00.3T, COAX 00.BT', COAX. 00.BT' ADAPTED, COAX 01 .65", CABLE 00. 16" C/W 0.79x3.94", CABLE 00. 16" + TURNBUCKLE, CABLE 00.16" + CHUCK, CABLE 00. 16" + THREADED END, CABLE 00.16" crimped end, CABLE 00. 16" open end, CABLE 00.16" C/W 0.79x3.94" COATED, CABLE 00. 16" C/W 2.36x0.79", Double CABLE 00.16" C/W</p>	

			1.5x9.65", REVERSED PROBE	
--	--	--	------------------------------	--

*Note:

1. "INTERFACE LEVEL", "INTERFACE CONVERSION", "INTERFACE DISTANCE", "INTERFACE DIST. CONV.", "LAYER" and "LAYER CONVERSION" are only available if you set application type to "LEVEL+ INTERFACE MIXED", "LEVEL + INTERFACE UNMIXED" or "INTERFACE (FULLY SUBMERGED PROBE)". "LEVEL CONVERSION", "DISTANCE CONY.", "INTERFACE CONVERSION", "INTERFACE DIST. CONV.," and "LAYER CONVERSION" are only available if you made a conversion table (strapping table).
2. Units and range depend on the output function, length unit and volume unit selected.
3. This depends on the data given in the customer order.
4. "CURRENT" and "RELAY" are only available if a second output option is in the customer order.
5. "INTERFACE WITH REVERSED PROBE" is only available if the device has a reversed interface probe. "LEVEL WITH GAS PHASE COMPENSATION" is only available if the device has the Dynamic Gas-phase Compensation [OGC] option.

- Supervisor Menu

The Advanced Setup menu is a list of procedures that have a more functions than the Auto Setup procedure. Press the [>] to go to Configuration mode. Enter the Supervisor password.

Table 12: Supervisor Menu

Menu No.	Function	Function Description	Selection List or Range of Values	Default
2.0.0 Supervisor Menu				
2.1.0 Identification				
2.1.1	Serial Number	The device serial number.	Read only.	
2.1.2	Conv Firm Version	The converter firmware version.	Read only.	
2.1.3	Sens Firm Version	The sensor firmware version.	Read only.	
2.1.4	HMI Firm Version	The HMI [device display screen] firmware version.	Read only.	
2.1.5	Electronic Revision	Electronic Revision is a series of numbers used to record the revision status of embedded software [firmware] in electronic equipment assemblies. It gives data on the type of changes made and the effect that changes have on compatibility.	Read only.	
2.1.6	Mechanical Traceability	The serial number for the probe and process connection.	Read only.	
2.2.0 Tests				
2.2.1	Set Current Output I1	Set Current Output. This sets analogue output 1 to a test value [mA] selected from a list. Output will change to the selected value, independent of the measured value.	3.5, 4, 6, 8, 10, 12, 14, 16, 18, 20 or 22mA	3.5mA
2.2.2	Diagnostic	This starts the hardware test. Press [▲] and [▼] many times to show, the functioning time, converter temperature, sensor temperature, current on loop, voltage 5.3 V, voltage on capacitors, voltage 3.3 V, reference pulse amplitude, flange pulse amplitude, level pulse amplitude, probe end pulse amplitude, reset counter and device	Read only.	

		status [this includes warning and error messages that are "on" at this time).		
2.2.3	Set Current Output I2	Set Current Output. This sets analogue output 2 to a test value [mA] selected from a list. Output will change to the selected value, independent of the measured value.	3.5, 4, 6, 8, 10, 12, 14, 16, 18, 20 or 22mA	3.5mA
2.2.4	Switch Output test	This function sends a test signal to show that the relay is open or closed.	OPEN, CLOSE	OPEN
2.2.5	Proof Test	If the device has the SIL option, it is necessary to do proof tests to make sure that the safety function is applicable to the full measuring range. We recommend that you do a proof test immediately after you install and start the device.		
2.3.0 Basic Parameter				
2.3.1	Tank Height	The distance from the tank connecting flange face / thread stop down to the tank value bottom.	min-max: 0 to 99.999 m/0 to 328.08ft	Probe length or value specified by the customer
2.3.2	Blocking Distance	The maximum non-measuring range at the top of the probe. It depends on the probe type and the installation. *Note: The reversed interface probe measures only from the bottom of the probe (interface level measurement), thus the device measures 2.3.2 Blocking Distance from bottom of the probe	Min:0 m/0ft Max: (2,3,4 Probe Length)	This depends on the probe type
2.3.3	Time Constant	This function gives the time over which the device will use readings to calculate the average measurement value. The device will show a smooth change in the readings if you increase the time constant. It is possible that the device will show sudden, irregular changes in the reading if you decrease the time constant.	Min-max: 0 to 100s	5 s
2.3.4	Probe Length	Probe length is the distance from the flange face / thread stop of the device down to the bottom end of the probe (including counterweight for cable versions). If probe length has been modified, enter the new value here.	min-max: Probe length depends on the measuring range for cable each type of probe. For more data about probe length.	This value is given in the customer order
2.3.5	Tag Name	The device has a code (tag name) to identify it. If the tag name is given in the customer order data, it will be set at the factory. A maximum of 8 characters can be used.		TANK 01 or text specified by the customer
2.3.6	Detection Delay	This parameter makes the device ignore reflections in a specified area immediately below the process connection. We recommend that this value is 2" (50mm)	Min: 0" (0mm) Max: (2,3,4, Probe Length)	0" (0mm)

		12.3.4 Probe Length less than the value in menu item 2.3.2 Blocking Distance.		
2.3.7	Reference Offset	Offset in relation to a reference location (distance). The device reference point for this parameter is the flange face of the flange (or thread stop if the device has a thread connection). This value is positive when the reference location is above the device flange face and negative if below.	Min-Max: - (tank height). +3000 m / - (tank height). +9842.52ft	0 m/ 0ft
2.3.8	Tank Bottom Offset	Offset in the relation to a reference location (level). The device reference point for this parameter is the bottom of the tank (set in menu 2.3.1 Tank Height). This value is positive when the reference location is below the tank bottom and negative if above.	Min-Max: -(Probe Length) +3000m/ - (Probe Length) +9842.52ft	0 m/ 0ft
2.4.0 Outputs				
2.4.1	Output Function I1	The output function for output 1. Make a I1 selection from a list of output functions to scale the current values in relation to a given point [usually the device process connection or the tank bottom). The output current value is shown on a bar graph in normal mode if the	Output Function I1	The output function for output 1. Make a I1 selection from a list of output functions to scale the current values in relation to a given point [usually the device process connection or the tank bottom). The output current value is shown on a bar graph in normal mode if the
2.4.2	Output Range I1	This menu item sets the limits of the output current range to 1 of the 2 available options: standard limits (4 to 20mA) or NAMUR NE 43-compliant limits (3.8 to 20.5mA). It also tells the device what to do if an error occurs. If you set Output Range 11 to and an error occurs (e.g., the tank is too full etc), the device output current will change to an error value of 22mA. If you set Output Range I1 to "4-20/3.6E" and an error occurs (e.g., the tank is empty etc.), the device output current will change to an error value of 3.6mA. If you set Output ' Range I1 to "4-20/HOLD" and the	4-20/3.6E, 3.8-20.5/22E, 4-20/3.6E, 3.8-20.5/3.6E, 4-20/HOLD, 4-20/22E	"4-20/22E"

		device senses a measurement error, the value will stop at the last correct measurement.		
2.4.3	Scale 4mA I1	This function gives a measurement value to 4mA (output 1).	min-max: (2)	(3)
2.4.4	Scale 4mA I1	This function gives a measurement value to 20mA (output 1).	min-max (2)	(3)
2.4.5	Output Error Delay	The time after which the current output changes to an error value. The error value shows that there is a measurement error. MN=minutes and S=seconds.	0 S, 10 S, 20 S, 30 S, 1 MN, 2 MN, 5 MN, 15 MN	10 S
2.4.6	Optional Output mode	This function operates the optional second output (output 2). If you set this function to "CURRENT", the second output supplies 4 to 20mA. Give the settings for this current output in Output Function 12, Scale 4mA 12 and Scale 20mA 12. If you set this function to "RELAY", the second output supplies a switch signal. Give the settings for this relay signal in Switch Function, Set Point/Threshold, Alarm Mode and Hysteresis. If Switch Function is set to "ERROR UST", set a condition in Error List only.	DISABLE, CURRENT, RELAY (4)	(3)
2.4.7	Output Function I2	The output function for output 2. Make a I2 selection from a list of output functions to scale the current values in relation to a given point [usually the device process connection or the tank bottom). The output current value is shown on a bar graph in normal mode if the measurement name (displayed measurement) is the same as the output function. Conversion parameters (DISTANCE CONV., LEVEL CONVERSION etc.) are shown if there is volume or mass data in menu item 1 .2.0 Conversion Setup. This function is available if Optional Output Mode is set to "CURRENT".	LEVEL, LEVEL CONVERSION, DISTANCE, DISTANCE CONV., INTERFACE LEVEL, INTERFACE CONVERSION, INTERFACE DISTANCE, INTERFACE DIST. CONV., LAYER, LAYER CONVERSION, DIELECTRIC PRODUCT, DIELECTRIC GAS, CONVERTER TEMPERATURE, SENSOR TEMPERATURE (1)	Distance
2.4.8	Output Range I2	This menu item sets the limits of the output current range to 1 of the 2 available options: standard limits (4 to 20mA) or NAMUR NE 43-compliant limits (3.8 to 20.5mA). It also tells the device what to do if an error occurs. If you set Output and an error occurs (e.g. the tank is too full etc), the device output current will change to an error value of 22mA. If you set Output Range I2 to "4-20/3.6E" and an error occurs (e.g. the tank is empty etc.), the device output current will change to an error	4-20/3.6E, 3.8-20.5/22E, 4-20/3.6E, 3.8-20.5/3.6E, 4-20/HOLD, 4-20/22E	"4-20/22E"

		value of 3.6mA. If you set Output ' Range I2 to "4-20/HOLD" and the device senses a measurement error, the value will stop at the last correct measurement.		
2.4.9	Scale 4mA I2	This function gives a measurement value to 4mA (output 2). This function is available if Optional Output Mode is set to "CURRENT".	min-max: (2)	(3)
2.4.10	Scale 4mA I2	This function gives a measurement value to 20 mA (output 2). This function is available if Optional Output Mode is set to "CURRENT".	min-max (2)	(3)
2.4.11	Switch Function	The switch function for output 2. Select from a list of switch functions to set the switch signal to the function that the device must monitor. For more data about the switch function, refer to Relay output.	LEVEL, LEVEL CONVERSION, DISTANCE, DISTANCE CONV., INTERFACE LEVEL, INTERFACE CONVERSION, INTERFACE DISTANCE, INTERFACE DIST. CONV., LAYER, LAYER CONVERSION, DIELECTRIC PRODUCT, DIELECTRIC GAS, CONVERTER TEMPERATURE, SENSOR TEMPERATURE, CURRENT mA, CURRENT%, ERROR LIST (1)	LEVEL
2.4.12	Set Point/Threshold	This function gives the point or threshold (level, distance etc) when the device will send the relay signal. This function is available if Optional Output Mode is set to "RELAY" and Switch Function is not set to "ERROR LIST".	min-max: (2)	-
	Error List	If Switch Function is set to "ERROR LIST", Error List replaces the Point/Threshold, Alarm Mode and Hysteresis steps in this procedure. This tells the device to send a relay signal ii the error condition specified in this step occurs.	OVERFILL, TANK EMPTY, INTERFACE LOST, CONV. TEMP. < MINI, CONV. TEMP. > MAXI, SNSR. TEMP. < MINI. SNSR. TEMP. > MAXI, DIELECT. CALC. FROZ., LEVEL LOST	-

2.4.13	Alarm Mode	“LOW LEVEL ALARM” tells the device to send the relay signal when the quantity of product in the tank is less than the threshold. “HIGH LEVEL ALARM” tells the device to send the relay signal when the quantity of product in the tank is more than the threshold. This function is available if Optional Output Mode is set to “RELAY” and Switch Function is not set to “ERROR LIST”.	LOW LEVEL ALARM, HIGH LEVEL ALARM	-
2.4.14	Hysteresis	If Alarm Mode is set to “LOW LEVEL ALARM”, this gives the quantity of product above the threshold where the relay goes back to “off” If Alarm Mode is set to “HIGH LEVEL ALARM”, this gives the quantity of product below the threshold where the relay goes back to “off” This function is available if Optional Output Mode is set to “RELAY” and Switch Function is not set to “ERROR LIST”.	min-max: (2)	-
	Delay	If the device senses an error, Delay is the interval (time limit) in seconds necessary for the device to record a ' change in status (from "off" to "on", or from "on" to "off"). If the device changes status again before the end of this time limit, then the device will not record the change. This function is available if menu Optional Output Mode is set to "RELAY" and menu item Switch Function is set to "ERROR LIST".	min-max: 0 to 99 s	1s or value specified by the customer
2.5.0 Application				
2.5.1	Tracking Velocity	This value must agree with the maximum rate of change of the level of the liquid contents in the tank.	min-max: 0.1 to 100 m/min	1.0 m/min
2.5.2	Epsilon R Gas	Dielectric constant (ϵ_r) of the gas in the tank. A major parameter for TDR level measurement devices. If the dielectric constant of the gas is very different from the default value (ϵ_{air}). set Epsilon R Gas to the ϵ_r value of the gas.	min-max: 1.0 to 15.00	1
	Epsilon R Product	You can use this menu to calculate the dielectric constant (ϵ_r) of the liquid contents automatically or manually in the tank. If it is necessary to change the value, do the auto Setup procedure.	MANUAL, AUTO	This depends on the parameter set in the Auto Setup procedure.
2.5.4	Level Threshold	If it is difficult to identify the level signal (for example: too many interference signals), you can increase the detection threshold. This value is measured in the thousandths (11 to 1000). A threshold of 100 is equivalent to 10% of the amplitude of the reference pulse at a distance of 1m/3.3ft from the flange facing or thread stop.	min-max: 0 to 1000	This depends on the process connection type, probe type, the converter type, and

				the product epsilon R.
2.5.5	Interface Threshold	If it is difficult to identify the interface signal (for example: too many interference signals), you can increase the detection threshold. This value is measured in the thousandths 11 to 1000). A threshold of 100 is equivalent to 10% of the amplitude of the reference pulse at a distance of 1 m / 3.3ft from the flange facing or thread stop.	min-max: 0 to 1000	This depends on the process connection type, probe type, the converter type, and the product epsilon R.
2.5.6	Probe End Threshold	For measurement in AUTOMATIC mode. If it is difficult to identify the probe end signal (for example: too many interference signals), you can increase the detection threshold. This value is measured in the thousandths 11 to 1000). A threshold of 100 is equivalent to 10% of the amplitude of the reference pulse at a distance of 1 m / 3.3ft from the flange facing or thread stop.	min-max: 0 to 1000	This depends on the process connection type, probe type, the converter type.
2.5.7	Measuring Mode	In DIRECT mode, the device measures the time it takes to receive a reflection of the signal from the surface of the tank contents. Direct mode is used for products with an er ≥ 1.6 (this value depends on the probe type). AUTOMATIC mode automatically switches the measuring mode between Direct and TBF mode. TBF mode is used to measure one product with a low er. In TBF mode, the device measures the time it takes to receive a reflection of the signal from the end of the probe.	DIRECT, AUTOMATIC	AUTOMATIC
2.5.8	Snapshot Mode	STATIC mode uses data from the quick setup procedure in the Auto Setup procedure. This mode identifies and filters interference signals from objects that do not move in the tank. Snapshot function data is saved if you de-energize the device. CAUTION! Do not set this menu item to STATIC mode before you do the quick setup procedure.	STATIC, DISABLE	STATIC
2.6.0 Communication				
2.6.1	Polling Address	Any HART® address greater than 0 will activate HART® multidrop mode. The current output stays constant at 4mA. If Polling Address is set to 0, the device will operate in point-to-point mode.	min-max: 0 to 63	0
2.6.2	SV Function	This is the second measurement type. shown on HART® controllers. Make a selection from the list.	LEVEL, LEVEL CONVERSION, DISTANCE, DISTANCE CONV., INTERFACE	DISTANCE

			LEVEL, INTERFACE CONVERSION, INTERFACE DISTANCE, INTERFACE DIST. CONV., LAYER, LAYER CONVERSION, DIELECTRIC PRODUCT, DIELECTRIC GAS, CONVERTER TEMPERATURE, SENSOR TEMPERATURE (1)	
2.6.3	TV Function	This is the third measurement type shown on HART® controllers. Select, from the list.	LEVEL, LEVEL CONVERSION, DISTANCE, DISTANCE CONV., INTERFACE LEVEL, INTERFACE CONVERSION, INTERFACE DISTANCE, INTERFACE DIST. CONV., LAYER, LAYER CONVERSION, DIELECTRIC PRODUCT, DIELECTRIC GAS, CONVERTER TEMPERATURE, SENSOR TEMPERATURE (1)	LEVEL
2.6.4	FV Function	This is the fourth measurement type shown on HART® controllers. Select from the list.	LEVEL, LEVEL CONVERSION, DISTANCE, DISTANCE CONV., NTERFACE LEVEL, INTERFACE CONVERSION, INTERFACE DISTANCE, INTERFACE DIST. CONV., LAYER, LAYER CONVERSION, DIELECTRIC PRODUCT,	DISTANCE

			DIELECTRIC GAS, CONVERTER TEMPERATURE, SENSOR TEMPERATURE (1)	
2.7.0 Display				
2.7.1	Language	Data can be shown in one of the languages stored in the device. Select from the list.	English, German, French, Italian, Portuguese, Spanish, Czech, Polish, Chinese (simplified), Japanese, Russian, Turkish	English or language specified by the customer
2.7.2	Display Length Unit	The length unit shown in normal mode.	m, cm, mm, in, ft	mm or units specified by the customer
2.7.3	Display Conversion Unit	The length, volume or mass conversion unit for the conversion table and shown in normal mode.	kg, t, Ston, Lton, m, cm, mm, in, ft m ³ , L, gal (US gallon), Imp (imperial gallon), ft ³ , bbl, m ³ /h, ft ³ /h	L (litre) or units specified by the customer
2.7.4	Password Yes/No	If it is necessary to protect your settings in the supervisor menu with a password, set this menu item to YES.	YES, NO	YES
2.7.5	Password	This changes the password for the supervisor menu. Press the buttons up to 6 times in any order. This will be the new password. To confirm the change, enter the new password a second time.		[>], [←], [↵], [↶], [↷] and [↸]
2.7.6	Contrast	The contrast control for the display screen. You can select a shade of grey between "no contrast" (level "0") and "black" (level "9").	min-max: 0 to 9	6
2.7.7	Clock Setting	Give the time format, date format, time, and date. If the device stays de-energized for more than two weeks, it will be necessary to set the time and date again.	Date/Clock format: YYYY/MM/DD 24h, DD/M M/YYYY 12h, DD/MM/YYYY 24h, YYYY/MM/DD 12h	YYYY/MM/D D 24h
			Set Clock	-
			Set Date	-
2.7.8	Display Mode	The measurement type shown in normal mode. If this function is set to a measurement	LEVEL, LEVEL	LEVEL

		type (e.g., Level), the device will always go back to this default measurement type in normal mode after 15 minutes.	DISTANCE, DISTANCE CONY., INTERFACE LEVEL, INTERFACE CONVERSION, "DISABLE" INTERFACE DISTANCE, INTERFACE DIST. CONV., LAYER, LAYER CONVERSION, DIELECTRIC PRODUCT, DIELECTRIC GAS, OUTPUT I, OUTPUT%, RELAY STATE, CONVERTER TEMPERATURE, SENSOR TEMPERATURE, TIME, DATE (5)	
2.8.0 Conversion Table				
2.8.1	Length unit	The length unit used to make the conversion table.	m, cm, mm, in, ft	
2.8.2	Conversion unit	The conversion unit used to make the conversion table.	kg, t, Ston, Lton, m, cm, mm, in, ft, m ³ , L, gal (US gallon), Imp (imperial gallon), ft ³ , bbl, m ³ /h, ft ³ /h	
2.8.3	Input Table	The device uses a conversion table (strapping table) to convert measurements to volume and mass readings. The readings are shown in normal mode. Go to this menu item and enter the entry number (01to30). Then enter the level and the related volume / mass value for that entry. Press [▲] to confirm the entry values. Continue the procedure until the device has data for all the entries.	min. 2 entries max. 30 entries (level / volume or mass)	0 entries
2.8.4	Delete Table	This menu item erases the data in the conversion table.	YES, NO	NO
2.9.0 Reset				
2.9.1	Restart Device	This menu item starts the device again.	YES, NO	NO
	Reset Factory	If you set this menu item to "YES", the device goes back to its initial settings (set by the manufacturer in the factory).	YES, NO	NO
2.10.0 History				
	A log of device errors. Press [>] to read the errors. Press [▲] or [▼] to scroll up or down the list. Each error is identified by a code. Press [>] again to show the number of incidents and the time since the last incident in days, hours, minutes, and seconds.			

*Note:

1. "INTERFACE LEVEL", "INTERFACE CONVERSION", "INTERFACE DISTANCE", "INTERFACE DIST. CONV.", "LAYER" and "LAYER CON-VERSION" are only available if you set Application Type to "LEVEL + INTERFACE MIXED", "LEVEL + INTERFACE UNMIXED" or "INTER- FACE (FULLY SUBMERGED PROBE)". "LEVEL CONVERSION", "DISTANCE CONV.", "INTERFACE CONVERSION", "INTERFACE DIST. CONV." and "LAYER CONVERSION" are only available if you made a conversion table (strapping table).
2. Units and range depend on the output function, length unit and volume unit selected.
3. This depends on the data given in the customer order.
4. "CURRENT" and "RELAY" are only available if a second output option is in the customer order.
5. "INTERFACE LEVEL", "INTERFACE CONVERSION", "INTERFACE DISTANCE", "INTERFACE DIST. CONV.", "LAYER" and "LAYER CON-VERSION" are only available if you set Application Type to "LEVEL + INTERFACE MIXED", "LEVEL + INTERFACE UNMIXED" or "INTER- FACE (FULLY SUBMERGED PROBE)". "LEVEL CONVERSION", "DISTANCE CONV.", "INTERFACE CONVERSION", "INTERFACE DIST. CONV." and "LAYER CONVERSION" are only available if you made a conversion table (strapping table). "RELAY STATE," is only available if menu Optional Output Mode is set to "RELAY".

Table 13: Default Values for Blocking Distance Menu

Probe type	Blocking distance	
	PTFE process seal system in (mm)	Ceramic process seal system in (mm)
∅ ¼" (∅8mm) single rod	2"(50)	8"(200)
∅ 1/8" (∅4mm) single cable	2"(50)	8"(200)
∅ ¾" (∅22mm) coaxial	2"(50)	2"(50)
∅ 1 ¾" (∅4mm) coaxial	2"(50)	2"(50)
∅ ¼" (∅8mm) double rod	2"(50)	8"(200)
∅ 1/8" (∅4mm) double cable	2"(50)	8"(200)
∅ 3/8" (∅10mm) reversed interface	2"(50)	8"(200)
Special 1	2"(50)	6"(150)

Table 14: Service Menu

Menu No.	Function	Function description	Selection list	Default
3.0.0	SERVICE	Advanced settings. The settings in this menu are protected with a password. Only approved personnel can change the parameters in this menu. For more data, speak or write to your local sales office.		

Table 15: Master Menu

Menu No.	Function	Function description	Selection list	Default
4.0.0	MASTER	Factory settings. The settings in this menu are protected with a password. Only approved personnel can change the parameters in this menu. For more data, speak or write to your local sales office.		

5.4 Device Configuration

5.4.1 Second Output

5.4.1.1 General Instruction

A second output is an optional output for Tek-Flex 4100A. If the device has a second output, then you can select from three output modes as follows:

- DISABLE (no output)
- CURRENT (4 to 20mA current output)
- RELAY (50 VDC / 6 A)

5.4.1.2 Electrical installation

For more data about electrical connection of the second output, refer to Electrical connections section 4.

5.4.1.3 Changing Output Mode

You can change the output mode as follows:

- The Auto Setup procedure (Optional Output mode).
- The Advanced Setup menu (sub-menu Output I2 Setup / Optional Output mode).
- The Supervisor menu (menu item Optional Output mode).

5.4.1.4 Current output

If the Optional Output mode is set to "CURRENT", then use the same procedures for output 1 for the current output settings:

- You will find data about device settings for level or level interface measurement.
- You will find data about device settings for distance or distance interface measurement.
- You will find data about device settings for volume, ullage volume, mass, and ullage mass measurement.

5.4.1.5 Relay

If the Optional Output mode is set to "RELAY", refer to Relay output.

5.4.2 Relay Output

5.4.2.1 General Instruction

- The relay output is available as an output mode for the optional second output.
- The relay sends an output signal when the switch function (level, distance, volume, current mA, converter temperature etc) is at a specified value.
- It can also send a signal if an error occurs (overflow, level lost, converter temperature above the maximum limit etc).

5.4.2.2 Changing Output Mode

You can change the output mode to "RELAY" as follows:

- The Auto Setup procedure (Optional Output mode).
- The Advanced Setup menu (sub-menu Output I2 Setup / Optional Output mode).
- The Supervisor menu (menu Optional Output mode).

5.4.2.3 Electrical installation

For more data about electrical connection of the relay output, refer to Electrical connections section 4.

5.4.2.4 Threshold

The threshold is the value at which the device sets the relay to "on" and sends a signal. To set the threshold, you must set Switch Function to the correct parameter (level, distance, volume, current mA, converter temperature etc.) and then give a value in Set Point/Threshold.

5.4.2.5 Alarm modes

- There are two alarm modes:
 - High level alarm
 - Low level alarm
- "Low level alarm" indicates the device to set the relay to "on" and send a signal when the quantity of product in the tank is less than the threshold.
- "High level alarm" indicates the device to set the relay to "on" and send a signal when the quantity of product in the tank is more than the threshold.

5.4.2.6 Changing Alarm Mode

You can change the alarm mode as follows:

- The Auto Setup procedure (Alarm mode).
- The Advanced Setup menu (sub-menu Output I2 Setup or Alarm Mode).
- The Supervisor menu (menu item Alarm Mode).

5.4.2.7 Hysteresis

- Hysteresis specifies the conditions when the relay status goes back to "off".
- If Alarm Mode is set to "HIGH LEVEL ALARM", then hysteresis is the quantity below the threshold where the relay status goes back to "off".
- If Alarm Mode is set to "LOW LEVEL ALARM", then hysteresis is the quantity above the threshold where the relay status goes back to "off". For example, if Switch Function is "CURRENT mA", Set Point/Threshold is "12.00mA", Hysteresis is "1mA" and Alarm Mode is "LOW LEVEL ALARM", then the relay status goes back to "off" when the measured current is 13mA.

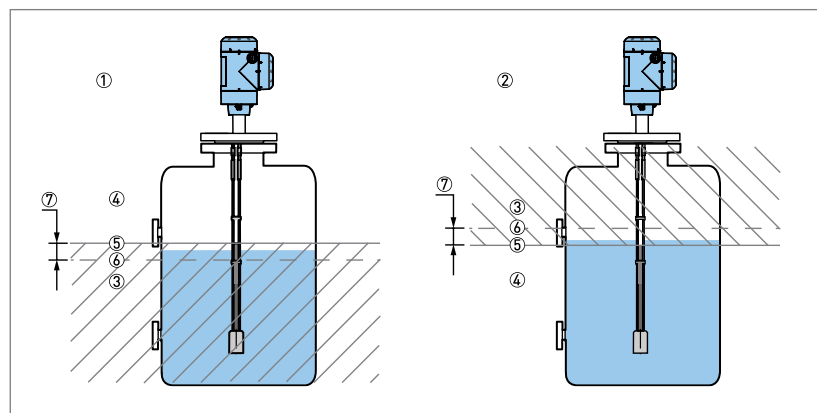

Fig 52: Relay Output: Alarm Mode, Threshold and Hysteresis

1. Device with relay output in "high alarm" mode.
2. Device with relay output in "low alarm" mode.
3. Relay output is set to "off".

4. Relay output is set to "on".
5. Continuous line: Level (threshold) at which the relay output changes to "on" (if Switch Function is set to "LEVEL"). The position of this threshold is specified in Set Point/Threshold.
6. Dotted line: Level at which the relay output goes back to "off" (if Switch Function is set to "LEVEL"). The position of this limit is specified in Hysteresis.
7. Dimension given in Hysteresis.

i NOTE

If the Switch Function is "LEVEL", Alarm Mode is "LOW LEVEL ALARM", Threshold is set to "1500mm" and Hysteresis is set to "10mm", then the relay output is set to "on" when the level of the tank contents is more than 1500mm. The relay output goes back to "off" when the level of the tank contents is less than 1490mm.

5.4.3 Device Protection Setting

- The menu Password lets you change the supervisor menu password.
- Process for changing the supervisor menu password:
- After you enter the supervisor menu, press [▲], [>] 6 × [▲], [>] and 4 × [▲] to go to the menu Password.
- Press [>] to start the procedure.
- Enter the old 6-character password. The factory-set password is [>], [←], [▼], [▲], [>] and [←].
- Enter the new 6-character password (press the 4 buttons in any sequence).
- Enter the new 6-character password again.
 - If the second entry is the same as the first, the device will go back to the sub-menu list.
 - If the second entry is not the same as the first, the device will start the password sequence again.
- Press [←] again to go back to the Store screen.
- Press [▼] or [▲] to set the screen to "STORE YES" and press [←].
 - The device will save the new password and go back to normal mode.

i NOTE

Make a note of the password and keep it in a safe place. If you lose the password, please speak, or write to your supplier.

- Setting the supervisor password to "on" or "off" as follows:
 - The supervisor password is set to "on" by default.
 - If it is necessary to set this function to "off", refer to Function description, Supervisor menu, menu Password Yes/No.

5.4.4 HART Network Configuration

- The device uses HART® communication to send information to HART® compatible equipment.
- It can operate in either point-to-point or multidrop mode.
- The device will communicate in multidrop mode if you change the address.



CAUTION

Ensure the address for this device is different from others in the multi-drop network.

5.4.4.1 Process for Changing Point-To-Point to Multidrop Mode

- Enter Supervisor menu.
- Press [>], 5 × [▲] and [>] to go to menu Polling Address.
- Press [>] to change the value. Enter a value between "001" and "063" and press [↵] to confirm (refer to the caution before this procedure).
- Press [↵] again and again to go back to the Store screen.
- Press [▲] or [▼] to set the screen to "STORE YES" and press [↵].
 - The output is set to multidrop mode. The current output is set to 4mA. This value does not change in multidrop mode.

5.4.4.2 Process for Changing Multidrop to Point-To-Point Mode

- Enter Supervisor menu.
- Press [>], 5 × [▲] and [▼] to go to menu Polling Address.
- Press [>] to change the value. Enter the value "000" and press [↵] to confirm.
- Press [↵] again and again to go back to the Store screen.
- Press [▲] or [▼] to set the screen to "STORE YES" and press [↵].
 - The output is set to point-to-point mode. The current output changes to a range of 4 to 20mA or 3.8 to 20.5mA (this range is set in menu Output Range I1).

5.4.5 Distance and Interface Distance measurement

- An output agrees with distance measurement when the output function is set to measure "DISTANCE". Menu used for distance measurement are as follows:
 - Output Function I1 (output 1)
 - Output Function I2 (optional output 2)
 - Tank Height
 - Blocking Distance
- An output agrees with interface distance measurement when the output function is set to "INTERFACE DISTANCE". Menu used for interface distance measurement are as follows:
 - Output Function I1 (output 1)
 - Output Function I2 (optional output 2)
 - Tank Height
 - Blocking Distance

- Use the flange facing or thread stop as the reference point for the 4 and 20mA current output settings. The 4 and 20mA current output settings are the minimum and maximum points of the measurement scale.



CAUTION

If the distance for 4mA is set in the blocking distance, the device will not be able to use the full current output range.

- You can change the reference point from which distance is measured.
- Use the menu Reference Offset.
- If you move the reference point above the flange, add this value when give a distance for the 4 and 20mA current output settings.
- If you move the reference point below the flange, subtract this value when you give a distance for the 4 and 20mA current output settings.

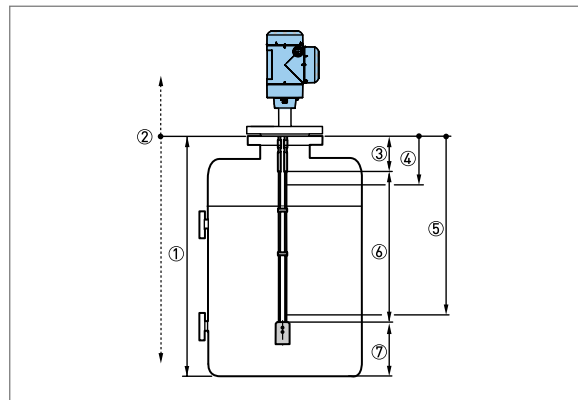

Fig 53: Distance or Interface Distance measurement

1. Tank height.
2. Reference Offset.
3. Blocking Distance.
4. Scale 4mA I1 (4mA setting for output 1).
5. Scale 4mA I2 (4mA setting for optional output 2).
6. Scale 20mA I1 (20mA setting for output 1).
7. Scale 20mA I2 (20mA setting for optional output 2).
8. Maximum effective measuring range.
9. Non-measurement zone.

5.4.6 Level and Interface Level Measurement

- An output matches with the level measurement when the output function is set to "LEVEL". Menu related to level measurement are as follows:
 - Output Function I1 (output 1)
 - Output Function I2 (optional output 2)
 - Tank Height
 - Blocking Distance

- An output matches with the interface level measurement when the output function is set to "INTERFACE LEVEL". Menu used for interface level measurement are as follows:
 - Output Function I1 (output 1)
 - Output Function I2 (optional output 2)
 - Tank Height
 - Blocking Distance
- Use the tank bottom as the reference point for the 4 and 20mA current output settings.
- The 4 and 20mA current output settings are the minimum and maximum points of the measurement scale.



CAUTION

If the level for 20mA is set in the blocking distance, the device will not be able to use the full current output range.

- You can change the reference point from which level is measured.
- Use the menu Tank Bottom Offset.
- If you move the reference point below the tank bottom, add this value when give a level for the 4 and 20mA current output settings.
- If you move the reference point above the tank bottom, subtract this value when you give a level value for the 4 and 20mA current output settings.

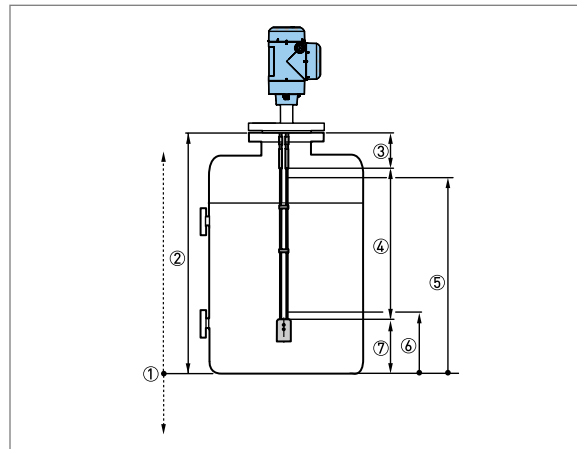

Fig 54: Level Measurement

1. Tank Bottom Offset
2. Tank Height
3. Blocking Distance
4. Maximum effective measuring range
5. Scale 20mA I1 (20mA setting for output 1)
6. Scale 20mA I2 (20mA setting for output 2)
 - Scale 4mA I1 (4mA setting for output 1)
 - Scale 4mA I2 (4mA setting for output 2)
7. Non-measurement zone

5.4.7 Configuration of the Device for mass and Volume

- The device can be configured to measure volume and mass.
- You can set up a strapping table in the Conversion Setup procedure or the Conversion Table menu. Each entry is a pair of data (level – volume or level – mass).
- The strapping table must have a minimum of 2 entries and a maximum of 50.
- The reference point for the table is the bottom of the tank (as given in menu Tank height).



CAUTION

Enter the data as per numerical sequence (strapping table entry number 01, 02 etc).

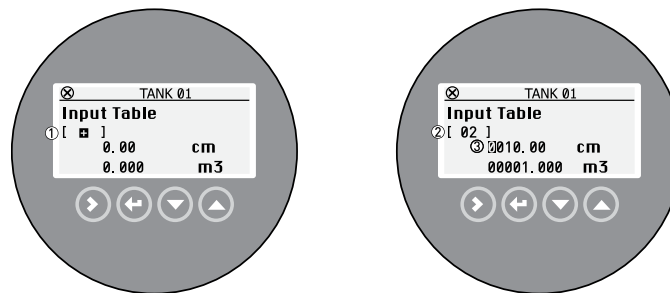

Fig 55: Strapping Table in Configuration Mode

1. The "+" sign is shown if there are no points on the conversion table. Press [\blacktriangle] when the cursor is on this sign to add a point on the table.
2. The conversion table is set to point "2".
3. The position of the cursor shows which digit can be changed.

5.4.7.1 Procedure for Prepare a strapping table (conversion table)

- After you enter Advanced Setup menu, press [\blacktriangle] and [\blacktriangleright] to start to the Conversion Setup procedure.
- Press [\blacktriangle] and [\blacktriangledown] to find the length unit (m, cm, mm, in or ft) that you will use in the table. Press [\blackleftarrow] to go to the next step.
- Press [\blacktriangle] and [\blacktriangledown] to find the conversion unit (m^3 , L, gal, Imp, ft^3 , bbl, kg, t, Ston, Lton, m, cm, mm, in or ft) that you will use in the table. Press [\blackleftarrow] to go to the next step.
- Press [\blacktriangleright] to make the first point on strapping table.
- The cursor moves to the length value (default value: 0000.00). Press [\blacktriangleright] to change the position of the cursor and then press [\blacktriangle] and [\blacktriangledown] to change the value of each digit. Press [\blackleftarrow] to go to the next step.
- The cursor moves to the conversion value (default value: 00000.000) Press [\blacktriangleright] to change the position of the cursor and then press [\blacktriangle] and [\blacktriangledown] to change the value of each digit. Press [\blackleftarrow], [\blacktriangleright] and [\blacktriangle] to make the second point on strapping table.
- The cursor moves to the length value (default value: 0000.00). Press [\blacktriangleright] to change the position of the cursor and then press [\blacktriangle] and [\blacktriangledown] to change the value of each digit. Press [\blackleftarrow] to go to the next step.
- The cursor moves to the conversion value (default value: 00000.000) Press [\blacktriangleright] to change the position of the cursor and then press [\blacktriangle] and [\blacktriangledown] to change the value of each digit.

Press [←], [→] and [▲] to make the subsequent point on strapping table. Repeat the last 2 steps to add more points to the table. If you have a sufficient number of points, press [←] to complete the procedure.

- Press [←] again and again to go back to the Store screen.
- Press [▲] or [▼] to set the screen to "STORE YES" and press [←].
 - The device will store the data for the strapping table and go back to normal mode.

- An output matches with the volume measurement when the output function is set to "Level conversion", "Interface conversion" or "Layer conversion". Menu related to volume measurement are as follows:
 - Output 1 Setup and Output Function I1 (output 1).
 - Output 1 Setup and Output Function I2 (optional output 2).
 - Tank Height.
 - Blocking Distance.

- An output matches with ullage volume (empty volume) measurement when the output function is set to "Distance conv." or "Interface dist. conv.". Menu related to ullage volume measurement are as follows:
 - Output 1 Setup and Output Function I1 (output 1).
 - Output 1 Setup and Output Function I2 (optional output 2).
 - Tank Height.
 - Blocking Distance.

- The device will give more accurate volume readings if you give more conversion data in these areas:
 - Surfaces with curves.
 - Sudden changes in the cross section.

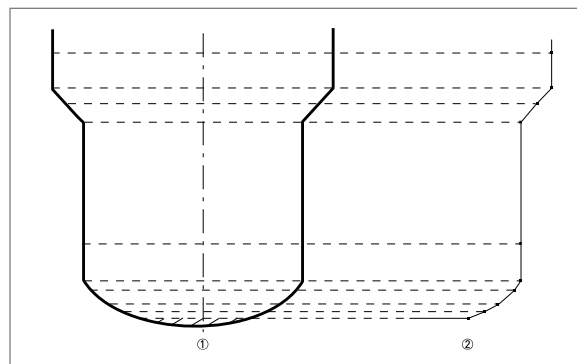

Fig 56: A Plot of Points for a Volume or Mass Table

1. Tank with reference points.
2. Tank model with plotted points.

5.4.7.2 Process for changing value in Strapping Table.

- After you enter the Advanced Setup menu, press [▲] and [>] to start to the Conversion Setup procedure.
- Press 2 × [←] to go to the conversion table.
- Press [▲] and [▼] to find the correct point in the table.
- Press [>]. The cursor moves to the length value. Press [>] to change the position of the cursor and then press [▲] and [▼] to change the value of each digit. Press [←] to go to the next step.
- The cursor moves to the conversion value. Press [>] to change the position of the cursor and then press [▲] and [▼] to change the value of each digit. Press [←] and then [▲] or [▼] to find a different point in the table. If you have completed the changes to the conversion table, the press [←] to complete the procedure.
- Press [←] again and again to go back to the Store screen.
- Press [▲] or [▼] to set the screen to "STORE YES" and push [←].
- The device will store the data for the strapping table and go back to normal mode.

5.4.7.3 Process for Deleting Volume or Mass Table

- Enter Supervisor menu.
- After you enter Supervisor menu, push 7 × [▲], [>], and 3 × [▲] to go to Delete Table.
- Press [>] and [▲] to set the parameter to "YES".
- Press [←] again and again to go back to the Store screen.
- Press [▲] or [▼] to set the screen to "STORE YES" and press [←].
- The device will delete the data for the strapping table and go back to normal mode. The device will not show Level Conversion, Distance Conversion, Interface Conversion, Interface Distance Conversion and Layer Conversion measurements in normal mode.

5.4.8 Dynamic Gas-phase Compensation (DGC)

- Gas phase compensation mode permits the device to measure level correctly when the dielectric constant (ϵ_r) of the gas above the tank contents changes.
- This is applicable to processes that are in high-pressure tanks (>40 barg / 580 psig) or where there is saturated vapour.
- These conditions can be found in boilers or tanks that contain ammonia, freon or liquid carbon dioxide.

i NOTE

Dynamic Gas-phase compensation (DGC) is an operation mode and a device option. If you did not include gas phase compensation in the customer order, then you can buy the activation code from your local sales office to unlock this option.

5.4.8.1 Process of Unlock the Dynamic Gas-phase Compensation Mode.

- Buy the activation code from your local sales office.
- After you enter the Advanced Setup menu, 4 × [▲], [>], [▲] and [>] to go to the menu item 1.5.2 Gas Phase Comp.

- Enter the alphanumeric activation code supplied by the sales office. Push [↵].
- Push [↵] again and again to go back to the Store screen.
- Push [▲] or [▼] to set the screen to "STORE YES" and push [↵].
 - The device will operate in gas phase compensation mode, but it is not calibrated to correctly measure level at this time.



CAUTION

Ensure you do an Auto Setup procedure before the device starts to measure level in gas compensation mode. The device must calculate the dielectric constant of the gas at this time. The settings in this procedure have an effect on the performance of the device.

5.4.8.2 Process for Operate the Device in the Dynamic Gas-Phase Compensation Mode

- Press [↵] more than one second and then [>] to start the Auto Setup procedure.
- Enter the correct settings for your process in date or clock format, set clock, set date, probe length, installation type and tank height.
- Set Application Type to "LEVEL WITH GAS PHASE COMPENSATION".
- Enter the correct settings for your process in Epsilon R Product, Output Function I1, Scale 4mA I1 and Scale 20mA I1.
- The device will start a process analysis.
- Is your tank partially filled or empty? Select from "Partially" and "Empty".
- The device starts a flange analysis.
- If the tank is partially filled, the device will find a measurement signal and show its distance from the process connection (flange facing or thread stop) of the device. If this distance is correct, press [▲] for "YES". If this distance is not correct, press [▼] for "NO".
- The device will then do a scan (snapshot) to find and filter interference signals caused by objects in the tank.
- Press [↵] to return to normal mode.



CAUTION

If all the data collected by the device are correct, it will operate the device in gas compensation mode and filter interference signals. If the data collected by the device is not correct, do the Auto Setup procedure again and change some settings. If this problem continues, contact to the manufacturer.



NOTE

The device can measure the dielectric constant of gas in the tank. You can show this data on the display screen or the device can send this data as a current output.

5.4.9 Threshold and Interference Signal

5.4.9.1 General Instruction

- The low-power electromagnetic signal from the device goes down the probe.
- The surface of the liquid products, and objects in the tank, make reflections.
- These reflections go back up the probe to the signal converter.
- The signal converter changes the reflections into voltage amplitudes.
- Reflections from objects in the tanks are interference signals.



CAUTION

If the device cannot measure level correctly, ensure you do the Auto Setup procedure with a snapshot analysis first to find and remove signal interference. If the device continues to measure level incorrectly, change the thresholds.

5.4.9.2 Process of thresholds working.

Thresholds let the device ignore reflections with small amplitudes and monitor changes in level and interface.

- The device uses the menu items that follow:
 - Level Threshold to set the threshold for the reflection on the top surface of the liquid products.
 - Interface Threshold to set the threshold for the reflection on the interface between two liquid products.
 - Probe End Threshold to set the threshold for the reflection on the end of the probe. If you must calculate the ϵ_r of the product or operate the device in AUTOMATIC mode, there must be a good probe end signal.
- The user can do a check of the signal amplitude after reflection on the surface of the liquid product or the liquid interface:
 - Level Threshold. Level threshold is the value that permits the device to find and measure the level of the tank contents. The level threshold must be set lower than the amplitude of the level signal. It is measured in thousandths (1 to 1000) of the reference pulse amplitude (value= 1000). The device measures the distance from the process connection to the level signal, and the signal amplitude. The signal converter then does a mathematical conversion (that agrees with a law of signal attenuation) to show the signal amplitude at a standard distance of 1m/3.3ft from the process connection. This value helps you to set the level threshold in this menu item.
 - Interface Threshold. Interface threshold is the value that permits the device to find and measure the interface between two liquid products in the tank. The interface threshold must be set lower than the amplitude of the interface signal. It is measured in thousandths (1to1000) of the reference pulse amplitude (value= 1000). The device measures the distance from the process connection to the interface signal, and the signal amplitude. The signal converter then does a mathematical conversion (that agrees with a law of signal attenuation) to show the signal amplitude at a standard distance of 1m/3.3ft from the process connection. This value helps you to set the interface threshold in this menu item.

- Probe End Threshold. Probe end threshold is the value that permits the device to find the end of the probe. The probe end threshold must be set lower than the amplitude of the probe end signal. This value is measured in thousandths (1 to 1000) of the reference pulse amplitude (value= 1000). The device measures the distance from the process connection to the probe end signal, and the signal amplitude. The signal converter then does a mathematical conversion (that agrees with a law of signal attenuation) to show the signal amplitude at a standard distance of 1 m / 3.3 ft from the process connection. This value helps you to set the probe end threshold in this menu item.

5.4.9.3 Process of how to use thresholds.

- Although the data that follows refers to the level threshold, it is applicable for the interface threshold and the probe end threshold.
- If there is an interference signal above the level and the threshold is very low, the device can incorrectly use it as the level signal.

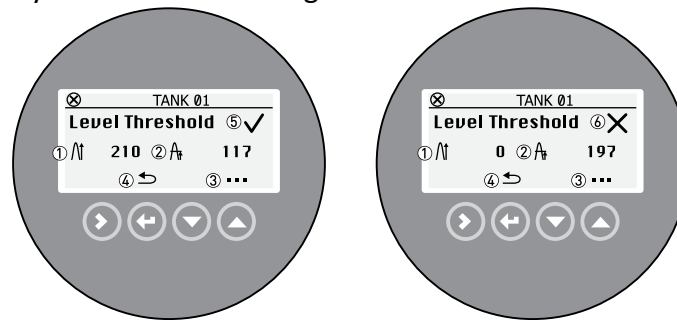

Fig 57: Process of How to use Threshold.

1. Signal amplitude
2. Threshold
3. Press [▲] to change the threshold value. Press [>] to change the position of the cursor and then press [▲] and [▼] to change the value of each digit. Press [↵] to set the value and go back to the first screen.
4. Press [↵] to go back to the sub-menu level.
5. The signal amplitude and the threshold are correct. The device can find the level signal.
6. The signal amplitude and the threshold are incorrect. The device cannot find the level signal.

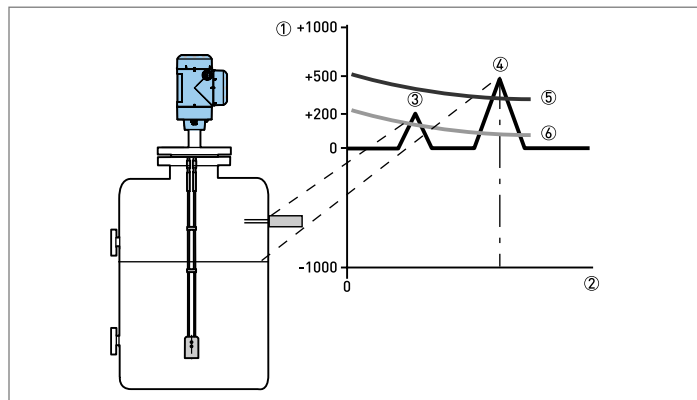

Fig 58: Signal Intensity or Thresholds Distance Graph

1. Signal intensity given as a fraction of the reference pulse (measured in thousandths).
2. Distance from the process connection.
3. Interference signal. A signal from a level switch that is in the limits of the electromagnetic field around the probe.
4. Level signal of the liquid products.
5. The level threshold is correct. The device ignores the interference signal and measures level correctly.
6. The level threshold is very low. The device can use the interference signal as the level signal. Do the Auto Setup procedure to make sure that the device ignores the interference signal.
 - After you enter Advanced Setup menu, 3 × [▲] to go to the menu Application Setup.
 - Press [>] to start the procedure.
 - Press [▲] or [▼] to change the Application Type parameter. If you have the Dynamic Gas-phase Compensation option, then set this menu item to "LEVEL WITH GAS PHASE COMPENSATION". If you have the Interface Capability option, then set this menu item to "LEVEL + INTERFACE MIXED", "LEVEL + INTERFACE UNMIXED" or "INTERFACE (FULLY SUBMERGED PROBE)". Press [←] to go to the next step.
 - ALTERNATIVE STEP A: If you know the dielectric constant value of the tank contents, then press [>] (Known) to enter the value. Press [>] to move the cursor to the next digit on the right. If the cursor is on the last digit, press [>] again to go back to the first digit. Press [▼] to decrease the digit value and [▲] to increase the digit value. Push [←] to go to the next step.
 - ALTERNATIVE STEP B: If you do not know the dielectric constant value of the tank contents, then push [▲] (Unknown) to give the product family. Press [▲] or [▼] to change the Product Family parameter. Press [←] to go to the next step.
 - Press [←] again and again to go back to the Store screen.
 - Press [▲] or [▼] to set the screen to "STORE YES" and press [←].
 - The device will save the new settings and go back to normal mode.

If the device cannot find the level signal after you do the procedure in menu Application Setup, then you can also manually change the threshold to find the signal. Do this procedure:

- Look at the level pulse amplitude value on left side of the first screen in menu item Level Threshold.
- Make a note of the amplitude of the correct level signal. Use this value to calculate the new value for the level threshold. The level threshold value used at this time is shown on right side of the first screen.
- Press [▲] to change the level threshold value.
- Increase the amplitude of the level threshold value. Press [>] to move the cursor to the next digit on the right. If the cursor is on the last digit, press [>] again to go back to the first digit. Press [▼] to decrease the digit value and [▲] to increase the digit value.
- This value must be more than the incorrect signal. We recommend that you set the level threshold at half the amplitude of the correct signal.
- Press [←] again and again to go back to the Store screen. Save the settings.

- The threshold increases. The device ignores the interference signal and uses the first signal that it finds.

5.4.9.4 Interface Threshold

- The device uses Direct mode to measure the level and interface level of products.
- If there are objects in the tank that can cause signal interference, change the interface threshold to ignore them.
- Use the same procedure in How to use thresholds to change the interface threshold but go to menu Interface Threshold.

5.4.9.5 Probe End Threshold

- The device uses Tank Bottom Following (TBF) mode to measure the level of products with low dielectric constants. It uses the probe end as a reference.
- If the reflection is very weak, change the probe end threshold to measure the probe end location.
- Use the same procedure in How to use thresholds to change the probe end threshold but go to menu Probe End Threshold.

5.4.10 Process to Decrease Length of Probe

5.4.10.1 Process to Decrease the Length of Single Rod Probes and Change the Device Setting

- Measure the length of the rod from the flange facing or thread stop. Use a scribe to put a mark on the rod.
- Cut the rod to the correct length.
- Enter Supervisor menu.
- Press [>], 2 × [▲], [>] and 2 × [▲] to go to menu Probe Length.
- Enter the new value. Press [←] to go back to the sub-menu level.
- Press 4 × [←] to save settings.
- Set the parameter to "STORE YES" and press [←].



CAUTION

Do the Auto Setup procedure after you decrease the probe length.

- Loosen the socket set screws that hold the counterweight with a 3mm Allen wrench.
- Remove the counterweight.
- Measure the length of the cable from the flange facing or thread stop. Use a scribe to put a mark on the cable.
- Add the length of the counterweight and subtract the length of the cable engaged in the counterweight. This gives the total probe length. Refer to the illustration and table that follows.
 - Cut the cable to the correct length.
 - Attach the cable to the counterweight. Tighten the socket set screws with a 3 mm Allen wrench.
- Enter Supervisor menu.
- Press [>], 2 × [▲], [>] and 2 × [▲] to go to menu Probe Length.

- Enter the new value. Press [←] to go back to the sub-menu level.
- Press 4 × [←] to save settings.
- Set the parameter to "STORE YES" and press [←].

6 Maintenance

6.1 Periodic Maintenance

In normal operational conditions, no maintenance is necessary. Only the manufacturer can repair the device and replace components. If it is necessary, maintenance must be done by approved personnel (the manufacturer or personnel approved by the manufacturer).



WARNING

Do not use bleach to clean the signal converter.

6.2 Device Cleaning Instructions

- Device cleaning instructions as follow:
 - Keep the thread of the terminal compartment cover clean.
 - If dirt collects on the device, clean it with a damp cloth.

6.3 Replacement of Device Components



WARNING

Only qualified personnel can do an inspection of the device and repairs. If you find a problem, send the device back to your supplier for inspection and/or repairs.



NOTE

For more precise information, please contact your local sales office.

Servicing by the customer is limited by warranty to:

- The removal and installation of the device.
- Compact version: The removal and installation of the signal converter (with the weather protection if this option is attached).
- Remote (field) version: The removal and installation of the remote converter and/or the probe housing.
- Replacement of signal converters of other TDR devices.

6.4 Availability of Services

The manufacturer offers a range of services to support the customer after expiration of the warranty. These include repair, maintenance, technical support, and training.



NOTE

For more precise information, please contact your local sales office.

6.5 Return Device to Manufacture

This device has been carefully manufactured and tested. If installed and operated in accordance with these operating instructions, it will rarely present any problems.



WARNING

Should you nevertheless need to return a device for inspection or repair, please pay strict attention to the following points:

- Due to statutory regulations on environmental protection and safeguarding the health and safety of the personnel, the manufacturer may only handle, test and repair returned devices that have been in contact with products without risk to personnel and environment.
 - This means that the manufacturer can only service this device if it is accompanied by the following certificate, confirm that the device is safe to handle.
-



WARNING

If the device has been operated with toxic, caustic, radioactive, flammable, or water-endangering products, you are kindly requested:

- To check and ensure, if necessary, by rinsing or neutralising, that all cavities are free from such dangerous substances.
 - To enclose a certificate with the device confirming that it is safe to handle and stating the product used.
-

6.6 Disassembling and Recycling

- This section shows you how to handle the device if it is unserviceable (i.e. it is at the end of its product life cycle) or if it must be discarded.
- Information given in this section agrees with the EU Directive 2012/19/EU on waste electrical and electronic equipment (WEEE) and the EU Directive 2008/98/EC on waste (Waste Framework Directive) Refer to the data and follow the instructions to disassemble and prepare components for waste treatment.



CAUTION

Before you disassemble the device for disposal and recycling, ensure the device is unserviceable. For more data about replacement parts, refer to spare parts or contact to the manufacturer.



NOTE

The device product does not contain dangerous gases or materials. If there is contamination from the process, refer to returning the device to the manufacturer

6.6.1 Compact Version

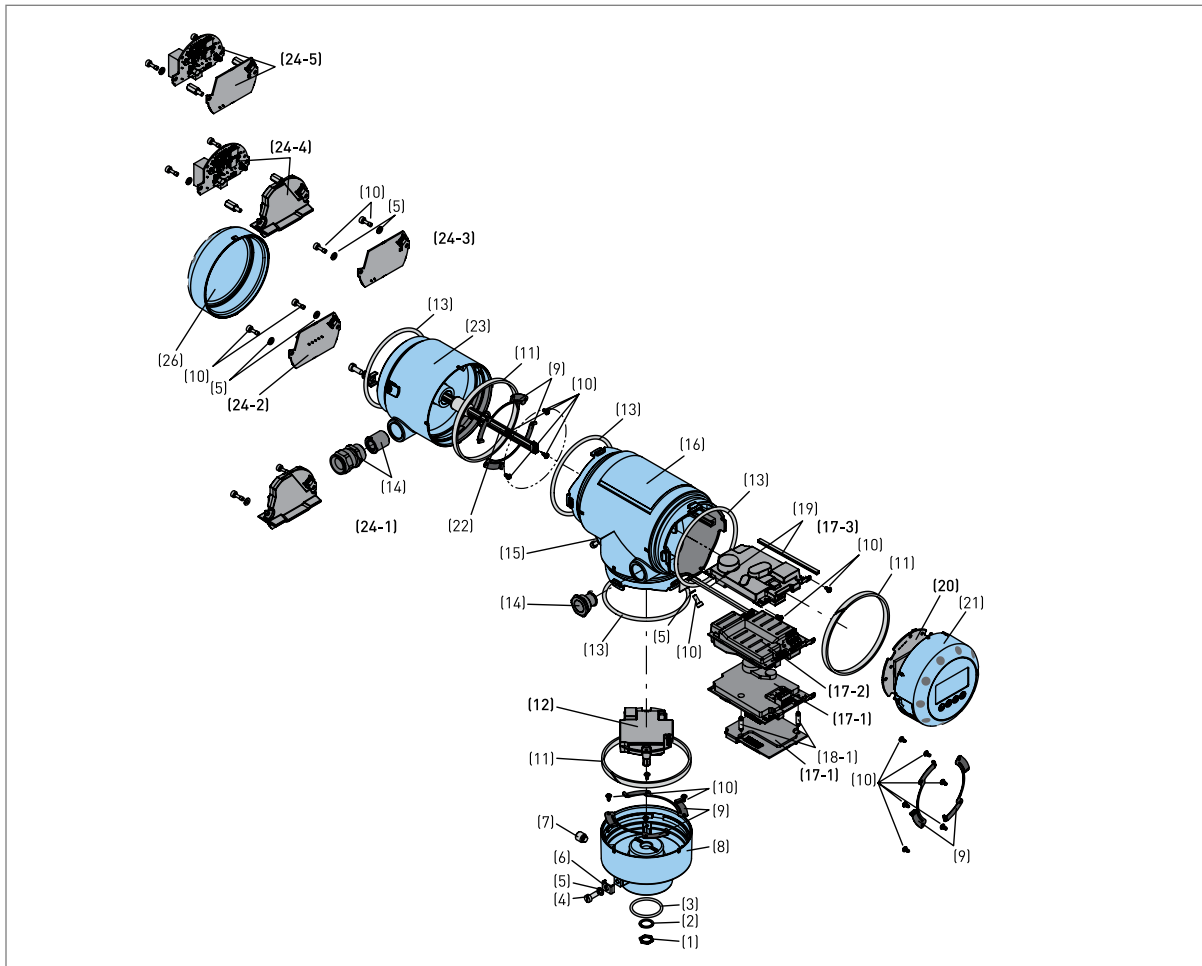

Fig 59: Part of Compact Version Device

Table 15: Part List for Compact Version

Item	Description	Material
(1)	Nut	Stainless Steel
(2)	Washer	Stainless Steel
(3)	Gasket	EPDM
(4)	Screw	Stainless Steel
(5)	Washer	Stainless Steel
(6)	Stirrup	Stainless Steel
(7)	Screw	Stainless Steel
(8)	Housing base	Aluminium or Stainless Steel (1)
(9)	Spring	CuBe2
(10)	Screw	Stainless Steel
(11)	Gasket	Neoprene + Ni-Cu
(12)	PCB 2	(3)
(13)	Gasket	Silicone
(14)	Cable gland	PEBD or PA or Nickel- Brass or Stainless Steel and/or Ferrite (1)
(15)	Blocker	PA 66
(16)	"T" housing	Aluminium or Stainless Steel (1)

(17)	PCB types 1, 2 or 3 4	(3)
(18)	Brace 1	PA 66
(19)	Guide 1	EPDM
(20)	PCB for display screen 1	(3)
(21)	Cover	Aluminium or Stainless Steel + PC
(22)	Feedthrough for Ex d /second output compartment 1	Ferrite + Rubber + Cables
(23)	Ex d housing 1	Aluminium or Stainless Steel (1)
(24)	PCB types 1, 2, 3, 4 or 5 1	3
(25)	Brace 1	Brass CW614N M Nickel finish
(26)	Cover	Aluminium or Stainless Steel (1)

*Note:

1. This depends on the device options.
2. PCB = Printed circuit board.
3. PCBs are potted with polyamide.
4. This depends on the output option.

Procedure for how to disassemble the compact version:

- Remove the housing base (8) and the parts attached to the housing base. Remove the PCB (12).
- If the device has the display screen option, remove the housing cover (21) and the parts attached to the housing cover.
- Remove the PCB (20) and the attached display screen.
- Remove the PCB (17) from the housing tee (16).
- If the device has an Ex d approval or the second output option, remove the Ex d housing (23) and the parts contained in the Ex d housing. Remove the PCB (24) from the Ex d housing.
- You can send the parts to the approved location for waste treatment or recycling.

Table 16: Materials and Components must be Removed and Independently Prepared for Treatment

Material	Weight		Description
	[kg]	[lb]	
Polychlorinated biphenyl	N/A	N/A	N/A
Mercury	N/A	N/A	N/A
Printed circuit boards, area > 10 cm ² / > 1.55 in ² - locations:			
housing base (12)	0.08	0.18	PCBs are potted with polyamide
"T" housing (17)	0.14 to 0.16 (1)	0.31 to 0.35 (1)	
cover (20)	0.09	0.20	
Ex d housing (24)	0.02 to 0.16 (1)	0.04 to 0.35 (1)	
Toner cartridge	N/A	N/A	N/A
LCD screen (device) area > 100 cm ² / > 15.5 in ²	N/A	N/A	The display screen option has an area of < 15 cm ² / < 2.3 in ²
Plastic that contains brominated flame retardants	N/A	N/A	< 0.1% in weight for PBB and PBDE. This agrees with the EU Directive 2011/65/EU (RoHS).
Asbestos	N/A	N/A	N/A
Cathode ray tube	N/A	N/A	N/A
CFC, HCFC, HFC or HC	N/A	N/A	N/A
Gas discharge lamp	N/A	N/A	N/A

External electric cable	N/A	N/A	N/A
Refractory ceramic fibers	N/A	N/A	N/A
Radioactive substance	N/A	N/A	N/A
Electrolyte capacitor > 25 mm / > 0.98"	N/A	N/A	N/A

*Note 1. This depends on the device options.

Table 17: Materials and Components which can Cause Problems in the Recycling Process

Material	Part (Item Number)	Weight		Description
		[kg]	[lb]	
Different Metals and Plastics (Sub-Assembly)	PCB, Housing Base (12)	0.08	0.18	FR-4, electronic components, polyamide potting
	PCB, "T" Housing (17)	0.14 to 0.16 (1)	0.31 to 0.35 (1)	
	PCB, Cover (20)	0.09	0.20	
	PCB, Ex D Housing (24)	0.02 to 0.16 (1)	0.04 to 0.35 (1)	
Different Metals and Plastics (Sub-Assembly)	Cable Gland (14)	~0.01	~0.02	PEBD or PA or nickel-brass or stainless steel and/or ferrite (1)
Different Metals and Plastics (Sub-Assembly)	Feedthrough (22)	~0.04	~0.09	Ferrite + rubber + Cables
Different Metals and Plastics (Sub-Assembly)	Cover, Aluminium (21)	0.19	0.42	Aluminium or stainless steel + polycarbonate (1)
	Cover, Stainless Steel (21)	0.63	1.39	
Different Metals	Housing	2.0 to 2.6	4.40 to 5.73	If the housing is made of aluminium, the screws and the washers are made of stainless steel
Different Plastics	N/A	N/A	N/A	N/A

*Note 1. This depends on the device options.

Table 18: Materials and Components which can be Recycled.

Stainless steel housing				
Material	Part (item number)	Weight		Description
		[kg]	[lb]	
Stainless steel	Nut (1)	5.5 to 7.2 (1)	12.12 to 15.87 (1)	N/A
	Washer (2)			
	Screw (4)			
	Washer (5)			
	Stirrup (6)			
	Screw (7)			
	Housing Base (8)			
	Screw (10)			
	"T" Housing (16)			
	Cover (21)			

	Ex D Housing (23)			
	Cover (26)			
Plastic	Gasket (11)	~0.05	~0.11	Neoprene + Ni-Cu
	Gasket (13)			Silicone
	Blocker (15)			PA 66
	Brace (18)			PA 66
Rubber	Gasket (3)	< 0.02	< 0.04	EPDM
	Gasket (19)			EPDM
Noble metals	Spring (9)	< 0.02	< 0.04	CuBe2
	Brace (25)			FR-4, Brass CW614N M Nickel finish
PCB	PCB (12)	0.22 to 0.5 (1)	0.48 to 1.10 (1)	FR-4, Electronic Components, Polyamide Potting
	PCB (17)			
	PCB (20)			
	PCB (24)			
Total (average weight)	—	~5.8 to 7.7 (1)	~12.7 to 16.98 (1)	N/A
Aluminium Housing				
Stainless steel	Nut (1)	~0.05	~0.11	N/A
	Washer (2)			
	Screw (4)			
	Washer (5)			
	Stirrup (6)			
	Screw (7)			
	Screw (10)			
Aluminium	Housing Base (8)	2.0 to 2.6 (1)	4.4 to 5.73 (1)	External surfaces are painted
	"T" Housing (16)			
	Cover (21)			
	Ex D Housing (23)			
	Cover (26)			
Plastic	Gasket (11)	~0.05	~0.11	Neoprene + Ni-Cu
	Gasket (13)			Silicone
	Blocker (15)			PA 66
	Brace (18)			PA 66
Rubber	Gasket (3)	< 0.02	< 0.04	EPDM
	Gasket (19)			EPDM
Noble metals	Spring (9)	< 0.02	< 0.04	CuBe2
	Brace (25)			FR-4, Brass CW614N M Nickel finish
PCB	PCB (12)	0.22 to 0.5 (1)	0.48 to 1.10 (1)	FR-4, Electronic Components, Polyamide Potting
	PCB (17)			
	PCB (20)			
	PCB (24)			

Total (average weight)	—	~2.3 to 3.1 (1)	~5.07 to 6.83 (1)	N/A
------------------------	---	-----------------	-------------------	-----

*Note 1. This depends on the device options.

6.6.2 Sensor Extension with Compact Version

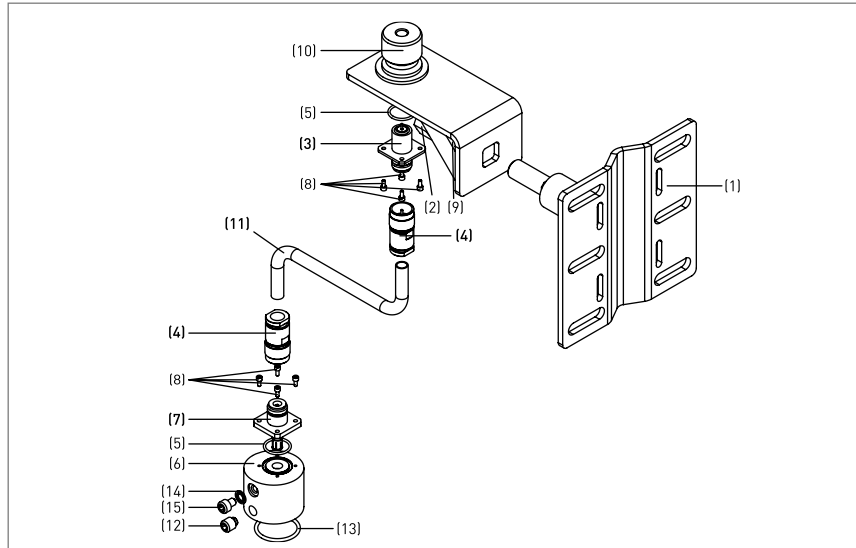

Fig 60: Parts of Sensor Extension with Compact Version

Table 19: Part List of Sensor Extension with Compact Version

Item	Description	Material
(1)	Wall fitting	316l
(2)	Nut	316l
(3)	Connector	PEEK + Copper + Stainless Steel
(4)	Connector	Brass + Silver Plating + PTFE
(5)	Gasket	EPDM
(6)	Adaptor	316l
(7)	Connector	PEEK + Copper + Stainless Steel
(8)	Screw	316
(9)	Washer	Stainless Steel
(10)	Housing support	316l
(11)	Cable	Copper + Polyethylene + PVC
(12)	Screw	316
(13)	Gasket	EPDM
(14)	Gasket	316 + EPDM
(15)	Screw	316

*Note 1. This depends on the device options.

Procedure for disassembling Sensor Extension:

- Remove the wall fitting (1).
- Remove the nut (2), the screws (8) and the screw (12).
- Remove the connectors (4) from the cable (11).
- You can send the parts to the approved location for waste treatment or recycling.

Table 20: Materials and Components which must be Removed and Independently Prepared for Treatment

Material	Weight		Description
	[kg]	[lb]	
Polychlorinated biphenyl	N/A	N/A	N/A
Mercury	N/A	N/A	N/A
Printed circuit boards, area > 10 cm ² / > 1.55 in ²	N/A	N/A	N/A
Toner cartridge	N/A	N/A	N/A
LCD screen (device) area > 100 cm ² / > 15.5 in ²	N/A	N/A	N/A
Plastic that contains brominated flame retardants	N/A	N/A	< 0.1% in weight for PBB and PBDE. This agrees with the EU Directive 2011/65/EU (RoHS).
Asbestos	N/A	N/A	N/A
Cathode ray tube	N/A	N/A	N/A
CFC, HCFC, HFC or HC	N/A	N/A	N/A
Gas discharge lamp	N/A	N/A	N/A
External electric cable	(1)	(1)	Discard the cable or collect the cable for treatment. This procedure must agree with EU Directive 2008/98/EC.
Refractory ceramic fibers	N/A	N/A	N/A
Radioactive substance	N/A	N/A	N/A
Electrolyte capacitor > 25 mm/ > 0.98"	N/A	N/A	N/A

*Note: 1 The sensor extension length will have an effect on the weight.

Table 21: Materials and Components which can cause Problems in the Recycling Process.

Material	Part (Item Number)	Weight		Description
		[kg]	[lb]	
Different Metals and Plastics (Sub- Assembly)	Cable (11)	(1)	(1)	Copper, PE, PVC
	Connectors (3), (4) and (7)	0.17	0.37	PEEK, Copper, Stainless Steel, Brass, Silver Plating, PTFE
Different Metals	N/A	N/A	N/A	N/A
Different Plastics	N/A	N/A	N/A	N/A

*Note: 1 The sensor extension length will have an effect on the weight.

Table 22: Materials and Components which can be Recycled.

Material	Part (item number)	Weight		Description
		[kg]	[lb]	
Stainless Steel	Wall Fitting (1)	~2.5	~5.51	N/A
	Nut (2)			
	Connector (4)			
	Adaptor (6)			
	Connector (7)			
	Screw (8)			
	Washer (9)			
	Housing Support (10)			
	Screw (12)			
	Gasket (14)			

	Screw (15)			
Plastic	Connector (3)	(1)	(1)	PEEK
	Connector (4)			PTFE
	Connector (7)			PEEK
	Cable (11)			PE + PVC
Rubber	Gasket (5)	< 0.02	< 0.04	N/A
	Gasket (13)			N/A
	Gasket (14)			
Noble Metals	Connector (3)	(1)	(1)	Copper
	Connector (4)			Brass + Silver Plating
	Connector (7)			Copper
	Cable (11)			Copper
Total (Average Weight)	—	> 2.6 1	> 5.73 1	N/A

*Note: 1 The sensor extension length will have an effect on the weight.

6.6.3 Remote Version

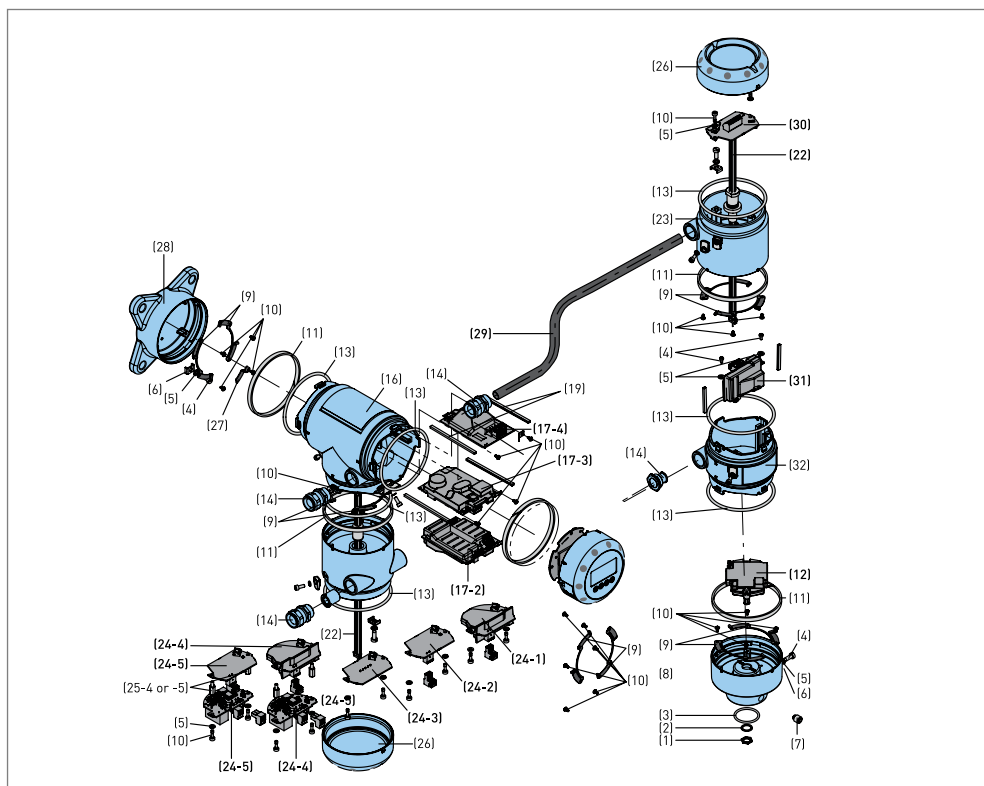

Fig 61: Parts of the Device for Remote Version

Procedure for Disassembling the Remote Version:

- Remove the housing base (8) and the parts attached to the housing base. Remove the PCB (12).
- Remove the probe electronics housing (32) and the parts attached to the probe electronics housing. Remove the PCB (31).

- If the device has an Ex d approval or the second output option, remove the Ex d housing (23) and the parts contained in the Ex d housing. Remove the PCB (30) from the Ex d housing.
- Remove the housing wall support (28) and the parts attached to the housing wall support.
- If the device has the display screen option, remove the housing cover (21) and the parts attached to the housing cover. Remove the PCB (20) and the attached display screen.
- Remove the PCB (17) from the "T" housing (16).
- If the device has an Ex d approval or the second output option, remove the Ex d housing (23) and the parts contained in the Ex d housing. Remove the PCB (24) from the Ex d housing.
- You can send the parts to the approved location for waste treatment or recycling.

Table 23: Materials and Components which must be Removed and Independently Prepared for Treatment

Material	Weight		Description
	[kg]	[lb]	
Polychlorinated Biphenyl	N/A	N/A	N/A
Mercury	N/A	N/A	N/A
Battery	N/A	N/A	N/A
Printed Circuit Boards, Area > 10 Cm ² / > 1.55 In ² - Locations:			
Housing Base (12)	0.08	0.18	PCBs are potted with polyamide
"T" Housing (17)	0.14 to 0.16 (1)	0.31 to 0.35 (1)	
Cover (20)	0.09	0.20	
Ex D Housing (24)	0.02 to 0.16 (1)	0.04 to 0.35 (1)	
Ex D Probe Electronics Housing (30)	0.01	0.02	
Probe Electronics Housing (31)	0.06	0.13	
Toner Cartridge	N/A	N/A	N/A
LCD Screen (Device) Area > 100 Cm ² / > 15.5 In ²	N/A	N/A	The display screen option has an area of < 15 cm ² / < 2.3 in ²
Plastic That Contains Brominated Flame Retardants	N/A	N/A	< 0.1% in weight for PBB and PBDE. This agrees with the EU Directive 2011/65/EU (RoHS).
Asbestos	N/A	N/A	N/A
Cathode Ray Tube	N/A	N/A	N/A
CFC, HCFC, HFC or HC	N/A	N/A	N/A
Gas Discharge Lamp	N/A	N/A	N/A
External Electric Cable	(2)	(2)	Discard the cable or collect the cable for treatment. This procedure must agree with EU Directive 2008/98/EC.
Refractory Ceramic Fibers	N/A	N/A	N/A
Radioactive Substance	N/A	N/A	N/A
Electrolyte Capacitor > 25 Mm / > 0.98"	N/A	N/A	N/A

*Note:

1. This depends on the device options.

2. The coaxial cable length will have an effect on the weight.

Table 24: Materials and Components which can cause Problems in the Recycling Process

Material	Part (Item Number)	Weight		Description
		[kg]	[lb]	
Different Metals and Plastics (Sub-Assembly)	PCB, Housing Base (12)	0.08	0.18	FR-4, Electronic Components, Polyamide Potting
	PCB, "T" Housing (17)	0.14 to 0.16 (1)	0.31 to 0.35 (1)	
	PCB, Cover (20)	0.09 (1)	0.20 (1)	
	PCB, Ex d Housing (24)	0.02 to 0.16 (1)	0.04 to 0.35 (1)	
	PCB, Probe Electronics (30)	0.01 (1)	0.02 (1)	
	PCB, Probe Electronics (31)	0.06 (1)	0.13 (1)	
Different Metals and Plastics (Sub-Assembly)	Cable Gland (14)	~0.01	~0.02	PEBD or PA or Nickel-Brass or Stainless Steel and/or Ferrite (1)
Different Metals and Plastics (Sub-Assembly)	Feedthrough (22)	~0.04	~0.09	Ferrite + Rubber + Cables
Different Metals and Plastics (Sub-Assembly)	Cover, Aluminium (21)	0.19	0.42	Aluminium or Stainless Steel + Polycarbonate (1)
	Cover, Stainless Steel (21)	0.63	1.39	
Different Metals and Plastics (Sub-Assembly)	Cable (29)	(2)	(2)	Option 1 Wire: tinned copper wire (24AWG) Insulation: datalene Core: two twisted pairs individually shielded with Beldfoil aluminium-polyester) (1)
				Option 2 Wire: bare copper wire (22AWG) Insulation: foamed Polyethylene (PE) with skin Ø2.1mm / 0.08" Core: 4 wires Jacket: Polyvinylchloride (PVC) 1
Different Metals	Housing	3.4 to 4.0	7.50 to 8.82	If the housing is made of aluminium, the screws and the washers are made of stainless steel
Different Plastics	N/A	N/A	N/A	N/A

*Note:

1. This depends on the device options.
2. The coaxial cable length will have an effect on the weight.

Table 25: Materials and Components which can be Recycled.

Material	Part (Item Number)	Weight		Description
		[kg]	[lb]	
Stainless steel housing				
Stainless steel	Nut (1)	7.8 to11.2 (1)	17.20 to 24.69 (1)	N/A
	Washer (2)			
	Screw (4)			
	Washer (5)			
	Stirrup (6)			
	Screw (7)			
	Housing Base (8)			
	Screw (10)			
	"T" Housing (16)			
	Cover (21)			
	Ex D Housing (23)			
	Cover (26)			
	Blocking Part (27)			
	Housing Wall Support (28)			
Probe Electronics Housing (32)				
Plastic	Gasket (11)	~0.1 (2)	~0.22 (2)	Neoprene + Ni-Cu
	Gasket (13)			Silicone
	Blocker (15)			PA 66
	Brace (18)			PA 66
	Cable (29)			PVC, PE
Rubber	Gasket (3)	< 0.05	< 0.11	EPDM
	Gasket (19)			EPDM
Noble metals	Spring (9)	< 0.05 (2)	< 0.11 (2)	CuBe2
	Brace (25)			Brass CW614N M Nickel finish
	Cable (29)			Copper
PCB	PCB (12)	0.3 to 0.6 (1)	0.66 to 1.32 (1)	FR-4, Electronic Components, Polyamide Potting
	PCB (17)			
	PCB (20)			
	PCB (24)			
	PCB (30)			
	PCB (31)			
Total (average weight)	—	~9.1 to 12.7 (1)	~20.06 to 28.00 (1)	N/A
Aluminium Housing				
Stainless steel	Nut (1)	~0.1	~0.22	N/A
	Washer (2)			
	Screw (4)			
	Washer (5)			
	Stirrup (6)			

	Screw (7)			
	Housing Base (8)			
	Screw (10)			
	Blocking Part (27)			
Aluminium	Housing Base (8)	2.9 to 4.0 (1)	6.39to 8.82 (1)	External surfaces are painted
	"T" Housing (16)			
	Cover (21)			
	Ex D Housing (23)			
	Cover (26)			
	Housing Wall Support (28)			
	Probe Electronics Housing (32)			
Plastic	Gasket (11)	~0.1 (2)	~0.22 (2)	Neoprene + Ni-Cu
	Gasket (13)			Silicone
	Blocker (15)			PA 66
	Brace (18)			PA 66
	Cable (29)			PVC, PE
Rubber	Gasket (3)	< 0.05	< 0.11	EPDM
	Gasket (19)			EPDM
Noble metals	Spring (9)	< 0.05 (2)	< 0.11 (2)	CuBe2
	Brace (25)			Brass CW614N M Nickel finish
	Cable (29)			Copper
PCB	PCB (12)	0.3 to 0.6 (1)	0.6 to 1.32 (1)	FR-4, Electronic Components, Polyamide Potting
	PCB (17)			
	PCB (20)			
	PCB (24)			
	PCB (30)			
	PCB (31)			
Total (average weight)	—	~3.5 to 4.8 (1)	~7.72 to 10.58 (1)	N/A

*Note:

1. This depends on the device options.
2. The coaxial cable length will have an effect on the weight.

6.6.4 Double sensor extension with remote version (D)

The double sensor extension with remote version (D) has a remote housing, a sensor extension, a coaxial cable, and a probe electronics housing. For more data about the components of the sensor extension, refer to Sensor extension with compact version (S). For more data about the components of the remote housing, coaxial cable, and the probe electronics housing, refer to Remote version (F).

7 Troubleshooting

7.1 Status and Error Message

7.1.1 Device Status

Diagnostic Menu (Configuration mode / Supervisor menu) supplies more data. This includes internal voltages, the loop current and the reset counter. You can see this data on the device display screen and in the DTM.

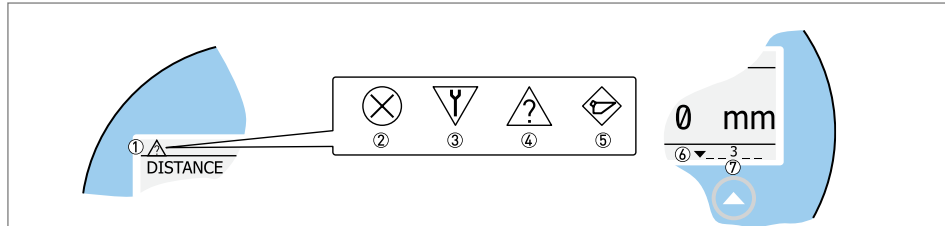





Fig 62: Status Markers

1. Device status (NAMUR NE 107 symbols)
2. Symbol: Failure
3. Symbol: Function check
4. Symbol: Out of specification
5. Symbol: Maintenance
6. Status Marker Line (marker 3 is shown)
7. When the status marker is on, a number is shown.

Table 26: Types of error message

Device Status	Type of error	Description
Failure	Error	If an error message is shown in History, the current output goes to the error signal value set in menu Output Range I1 (and Output Range I2 if the device has the optional second output) after the time set in menu Output Error Delay. For more data about menu, refer to Function description.
Out of specification	Warning	If a warning message is shown, there is no effect on the current output value.
Maintenance		

Symbol shown	Status	Description Status	Status marker shown	Error code (Type)	Possible errors
⊗	Failure	The device does not operate correctly. The fault message stays on. The user cannot remove the "Failure" message from the Normal mode screen.	1	101 (Error)	Current Output Drift
			3	102 (Error)	Temperature Out of Range
			1	103 (Error)	Converter EEPROM
			1	103 (Error)	Converter RAM
			1	103 (Error)	Converter ROM
			1	104 (Error)	Converter Voltage
			2	200 (Error)	Reference Lost
			2	202 (Error)	Peak Lost (Level Lost)
			3	203 (Error)	Sensor Processing Failure
2	204 (Error)	Overfill			

			3	205 (Error)	Internal Communication
			1	206 (Error)	No Probe detected
			1	207 (Error)	Sensor EEPROM
			1	207 (Error)	Sensor RAM
			1	207 (Error)	Sensor ROM
			1	208 (Error)	Oscillator Frequency
			3	209 (Error)	Sensor Not compatible
			2, 4	210 (Error)	Empty
				211 (Error)	Sensor Hardware Failure
			4	214 (Error)	Interface Measurement Failure
			1	501 (Error)	Optional Output Failure
	Function check	The device operates correctly, but the measured value is incorrect. This fault message is only temporary. This symbol is shown when the user configures the device with the DTM or a HART® Communicator.	—	—	—
	Out of specification	It is possible that the measured value is unstable if the operating conditions do not agree with the device specification.	4	(Warning)	Peak Lost
			4	(Warning)	Overfill
			4	(Warning)	Empty
			4	(Warning)	Temperature out of range
	Maintenance	The device does not operate correctly because of bad environmental conditions. The measured value is correct, but maintenance is necessary a short time after this symbol is shown.	5	(Warning)	Snapshot Invalid
			4	(Warning)	Flange Lost
			4	(Warning)	Reference Position Outside Range
			4	(Warning)	Audio Signal Offset Outside Range
			3	(Warning)	Temperature <-35°C / -31°F (1)
			3	(Warning)	Temperature >+75°C / +167°F (1)
—	—	—	6	(Warning)	Probe End Analysis Not Valid

*Note 1. The device display screen does not operate at this temperature. If an "Out of specification" status symbol is shown, refer to Diagnostic Menu (Configuration mode / Supervisor menu) for more data. For data on errors, error records and error codes, refer to Error handling section.

7.1.2 Error Handling

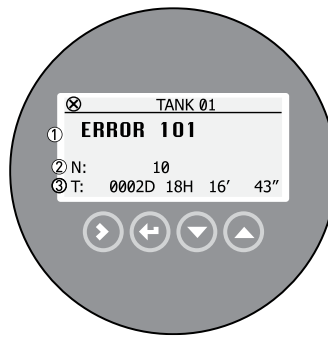

Fig 66: Error Record Data

1. Error code for the error
2. Number of times the error occurred
3. Time since the last error record (2 days, 18 hours, 16 minutes, and 43 seconds shown in this example)

Procedure for find an Error Record:

- Push [>] and [▲] to enter configuration mode from normal mode.
- Push [>], 9 × [▲] and [>] to go to History menu.
- Push [>] to look at errors recorded by the device. Push [▲] or [▼] for the selection of an error.
- The error record gives the number of times the error occurred and the time since the last error message.

i NOTE

The time since the error occurred is measured in Days (D), Hours (H), Minutes (') and Seconds ("). It only includes the time when the device is energized. The error is saved in the memory of the device when it is de-energized. The counter continues when the device is energized again.

Table 27: Description of Data in Diagnostic Menu

Hardware Test	Description	Normal Operating Range	Full Range	Cause	Corrective Action
Functioning time	This shows the time in hours that the device is energized.	—	—	—	For information only.
Reset counter	This shows the number of times that the device starts again.	—	—	—	For information only.
Temperature, converter	This shows the temperature (in °C) of the converter board.	-40 to +80°C	-50 to +85°C	See error 102 in the table that follows.	See error 102 in the table that follows.
Loop current	This shows the current output of the device (in mA).	4 to 20 mA	—	—	—
Voltage 5.3 V	Voltage transmitted to the sensor board	5.2..... V	5.2..... V	—	If the device senses a hardware error, give this data to your supplier.

Voltage on capacitors	Voltage transmitted to the capacitor on the converter board	10 to19 V	10 to19 V	—	If the device senses a hardware error, give this data to your supplier.
Voltage 3.3 V	Voltage transmitted to the sensor board and the converter board	3.2..... V	3.2..... V	—	If the device senses a hardware error, give this data to your supplier.
Amplitude, reference pulse	Absolute amplitude of the reference signal converted to a digital sample.	1000 to 5000	0 to 6000	—	If the device senses a hardware error, give this data to your supplier.
Amplitude, flange pulse	Absolute amplitude of the flange signal converted to a digital sample.	0 to 1000	0 to 1000	—	If the device senses a hardware error, give this data to your supplier.
Amplitude, level pulse	Absolute amplitude of the level signal converted to a digital sample.	0 to 1000	0 to 1000	—	If the device senses a hardware error, give this data to your supplier.
Amplitude, interface pulse	Absolute amplitude of the interface signal converted to a digital sample.	0 to1000	0 to1000	—	If the device senses a hardware error, give this data to your supplier.
Amplitude, probe end pulse	Absolute amplitude of the probe end signal converted to a digital sample.	0 to 1000	0 to 1000	—	This is not applicable to this version of the device.

Table 28: Description of Errors and Corrective Actions

Error code	Error Message	Status marker shown	Cause	Corrective action
Back End Errors				
100	Device reset	1	The device detected an internal error.	Record the data that is in Diagnostic Menu (Configuration mode / Supervisor menu). Speak or write to your supplier.
101	Current output drift	1	The current output is not calibrated.	Speak or write to your supplier to get the calibration procedure.
		1	Hardware error.	Replace the device.
102	Temperature out of range	3	The ambient temperature is outside the given range. This can cause loss or corruption of data.	Measure the ambient temperature. De-energize the device until the ambient temperature is back in the given range. If the temperature does not stay in the correct range, make sure that there is insulation around the signal converter.
103	Converter memory failure	1	The device's hardware is defective.	Replace the signal converter.
104	Converter voltage failure	1	The device's hardware is defective.	Replace the signal converter.
Sensor Errors				
200	Reference pulse lost	2	Reference amplitude is less than reference threshold. This fault could occur because the device hardware is defective.	Speak or write to your supplier to make sure that the electronics are still functioning correctly. Ensure that your installation has ESD protection.
201	Sensor voltage failure	1	The device's hardware is defective.	Do a check of the power supply at the device terminals. Make sure

				that voltage values are in the specified limits in Diagnostic Menu (Configuration mode / Supervisor menu). If the voltage is correct, replace the signal converter.
203	Level lost error	2, 4	The device cannot find the product surface. The measurement stops at the last measured value.	Measure the level of the contents in the tank using another method of measurement. If the tank is empty (the level is below the end of the probe), then fill the tank until product level is in the measurement range. If the tank is full (the level is in the blocking distance), then remove the contents from the tank until the level is back in the measuring range. If the product was lost and the tank is neither full nor empty, wait for the device to find the level again.
		2, 4	The device cannot find the level return signal and the probe end return signal.	
				If the device has to measure a product with ϵ_r , refer to the level signal value in menu Level Threshold and then adjust the level threshold. If the product has a low dielectric constant ($\epsilon_r < 1.6$) and the device is in "Automatic" measurement mode, refer to the probe end signal value in menu Probe End Threshold and then adjust the probe end threshold. For more data, refer to Thresholds and interference signals.
				Make sure that the signal converter is correctly attached to the probe..
204	Overfill error	2, 4	The level is in the blocking distance. There is a risk that the product will overflow and/or cover the device.	Remove some of the product until the level is below the blocking distance.
205	Internal Communication	3	The device's hardware or software is defective. The converter cannot transmit signals to or receive signals from the probe electronics.	De-energize the device. Make sure that the signal cable engages in the terminal and the screw connection is tight. Energize the device. If the problem continues, replace the signal converter.
206	No sensor detected	2	The device's hardware is defective.	Replace the signal converter.
207	Sensor memory failure	1	The device's hardware is defective.	Replace the signal converter.
208	Oscillator Frequency	1	The device's hardware is defective.	Replace the signal converter.
209	Sensor not compatible	1	The software version of the sensor is not compatible with the software version of the signal converter.	Go to menu Identification in Configuration mode. Record the version numbers of the device software given in menu. Give this data to your supplier.
		1	Defective wiring.	

210	Empty	2, 4	The level is in the bottom dead zone. There is a risk that the tank is empty.	Add some of the product until the level is above the bottom dead zone.
211	Sensor Hardware Failure	1	The device's hardware is defective.	Replace the probe. For more data, refer to How to turn on or remove the signal converter on page 48.
214	Interface Measurement Failure	4	The device cannot find the interface. The measurement stops at the last measured value. The interface is in the measuring range.	If the product was lost and the tank is neither full nor empty, wait for the device to find the level again. If the device has to measure a product with a small difference between the dielectric constant (ϵ_r) of the top product and the bottom product, refer to the interface signal value in menu Interface Threshold and then adjust the interface threshold.
				Make sure that the signal converter is correctly attached to the probe.
		4	The device cannot find the interface. The measurement stops at the last measured value. The interface is in the top dead zone.	Remove the contents from the tank until the interface is back in the measurement range.
		4	The device cannot find the interface. The measurement stops at the last measured value. There is no interface (there is no top product or bottom product) or the layer is less than 50 mm / 2".	If there is no top product in the tank, then fill the tank until the layer of top product is more than 50 mm / 2".
		4	The device cannot find the interface. The measurement stops at the last measured value. The tank is empty or the interface is in the bottom dead zone.	If the tank is empty (the level is below the end of the probe), then fill the tank until product level is in the measurement range.
501	Optional Output Failure	1	The current output is not calibrated.	Speak or write to your supplier to get the calibration procedure.
		1	Hardware error.	Replace the device.
Maintenance (Status Signal)				
—	Snapshot Invalid	5	The "static" snapshot data stored in the device does not agree with the installation. If you change the device configuration (probe length etc.), this message will be shown. The recorded "static" snapshot data will not be used by the device while this error message is shown. (1)	Do the Auto Setup procedure again.
—	Flange Lost	4	The signal converter cannot find the probe below the flange. Is the signal converter attached to the process connection?	Make sure that the signal converter is attached to the process connection. If this status does not change, speak or write to your supplier.
—	Reference Position Outside Range	4	The device's hardware is defective. (1)	Replace the signal converter.
—	Audio Signal Offset Outside	4	The device's hardware is defective. (1)	Replace the signal converter.

	Range			
—	Temperature <-35°C / -31°F 2	3	The ambient temperature is less than -35°C / -31°F. This temperature is near to the minimum limit for device operation. (1)	Measure the ambient temperature. If the temperature does not stay in the correct range, make sure that there is insulation around the signal converter.
—	Temperature >+75°C / +167°F 2	3	The ambient temperature is more than +75°C / +167°F. This temperature is near to the maximum limit for device operation. (1)	Measure the ambient temperature. If the temperature does not stay in the correct range, make sure that there is insulation around the tank.
Other Warnings				
—	Probe End Analysis Not Valid	6	This warning is shown if you decrease the probe length and it is not the same as the value used in the device settings (menu Probe Length). The recorded probe length calculation will not be used by the device while this error message is shown.	Do the Auto Setup procedure again.
			This warning is shown if the value set at this time in menu Epsilon R Gas is different from the dielectric constant of the gas in the tank. The recorded probe length calculation will not be used by the device while this error message is shown.	

*Note

1. This error message does not have an effect on the current output signal.
2. The device display screen does not operate at this temperature.



TEKMATION LLC reserves the right to change the designs and/or materials of its products without notice. The contents of this publication are the property of TEKMATON and cannot be reproduced by any other party without written permission. All rights reserved. Copyright © 2020 TEKMATON LLC
DOC#/TEK/PO/MNU/21119/4/00A/01.4
TEKMATION LLC



www.tek-trol.com

Tek-Trol LLC

796 Tek Drive Crystal Lake, IL 60014,
USA

Sales: +1 847-857-6076

Support: +1 847-857-6076

Email: tektrol@tek-trol.com

www.tek-trol.com

Tek-Trol is a fully owned subsidiary of TEKMATON LLC. We offer our customers a comprehensive range of products and solutions for process, power and oil & gas industries. Tek-Trol provides process measurement and control products for Flow, Level, Temperature & Pressure Measurement, Control Valves & Analyzer systems. We are present in 15 locations globally and are known for our knowledge, innovative solutions, reliable products and global presence.

Flow | Level | Temperature | Pressure | Valves | Analyzers | Accessories | TekValSys