

Tek-Clamp 1200A-100H

Handheld Ultrasonic Flow Meter



Quick Start Guide

1. Before you begin



Make sure the transmitter is installed by qualified personnel and in accordance with the applicable code of practice.



Disconnect the power before servicing, to prevent ignition of flammable or combustible atmospheres.



Turn off the main power source to the Tek-Clamp 1200A -100H band ensure lines to any other external power sources are disconnected, or not powered while wiring the flow meter.



Make sure only qualified personnel perform the installation.



Do not perform any service other than those contained in this manual unless qualified.

2. Unpack

1200A-100H Handheld Ultrasonic Flow Meter

3. Dimensional Drawing

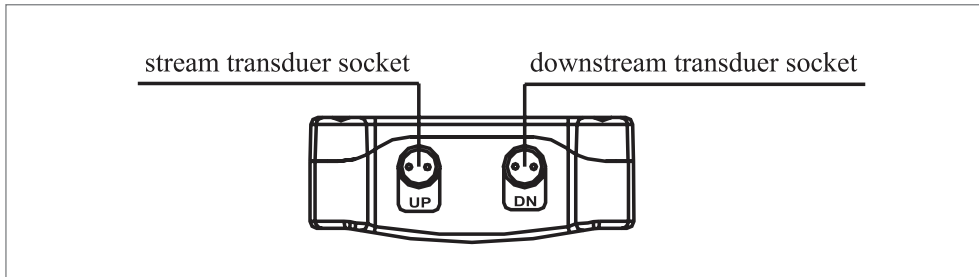

Fig 1: Top View of 1200A-100H Handheld Ultrasonic Flow Meter

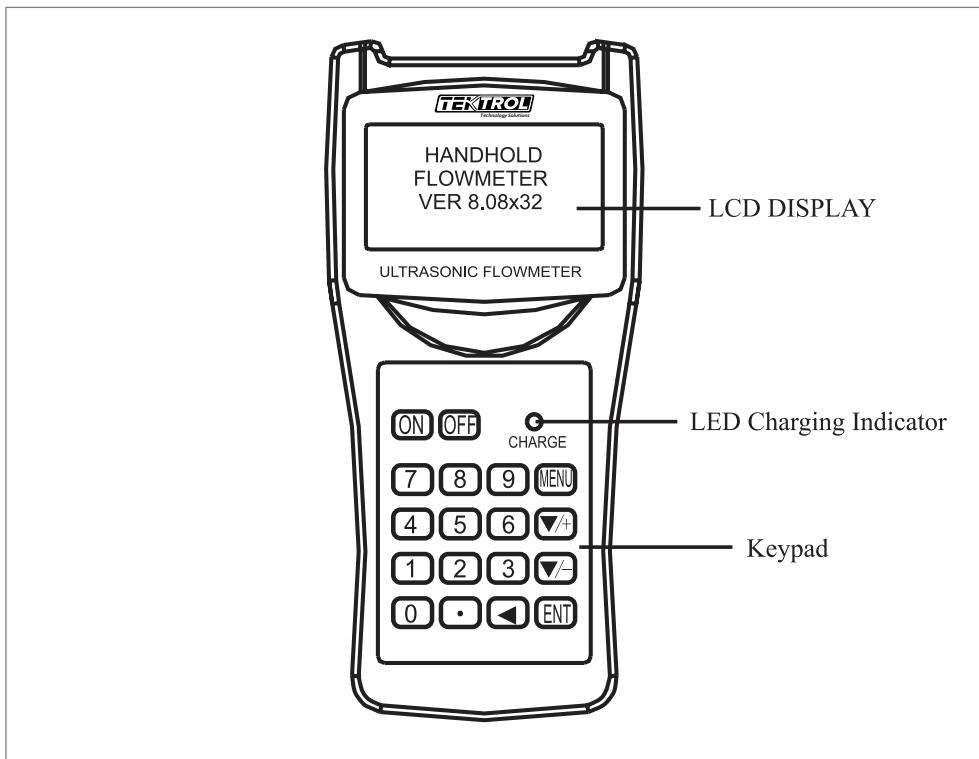

Fig 2: Front View of 1200A-100H Handheld Ultrasonic Flow Meter

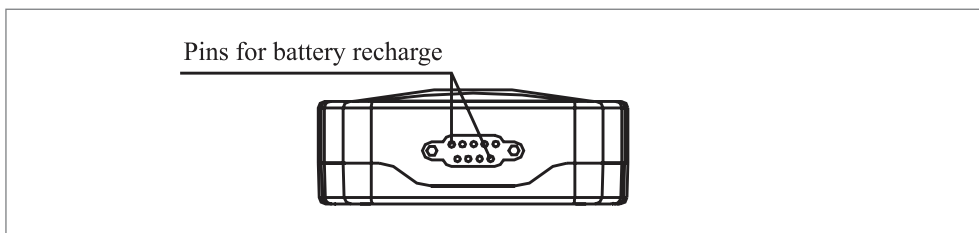

Fig 3: Bottom View of 1200A-100H Handheld Ultrasonic Flow Meter

Quick Start Guide

4. Mountings

V Method

The transducers of the Tek-Clamp 1200A-100H Handheld Ultrasonic Flow Meter mounted by V method.

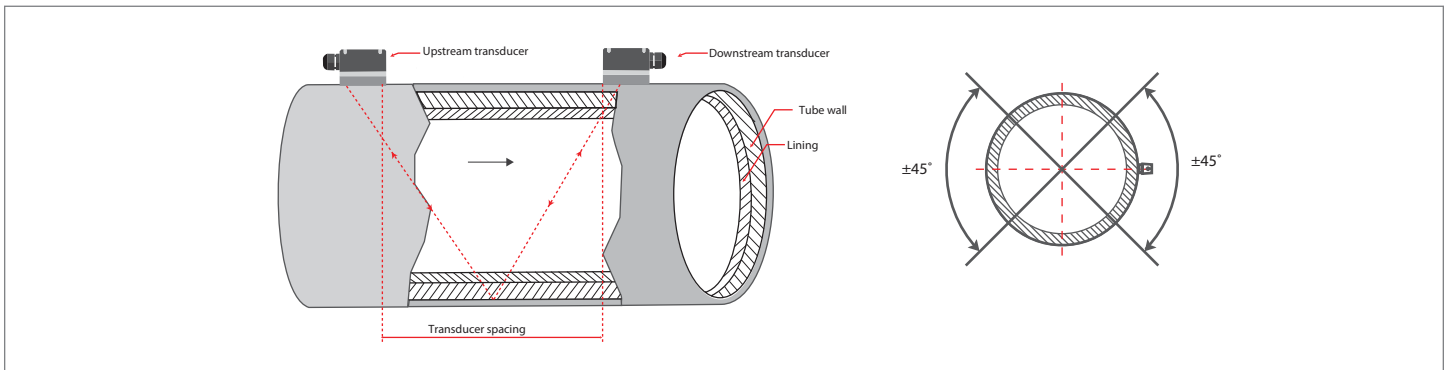

Fig 4: V type Mountings of Tek-Clamp 1200A-100H Handheld Ultrasonic Flow Meter

The V method is a standard installation method and convenient to use for precise measurement of flow. While installing the two transducers, they are horizontally aligned. The transducers center lines are parallel with the pipe axis line. They are suitable for pipe diameter range $\frac{1}{2}$ " to 16" (DN 15mm to DN 400mm).

Z Method

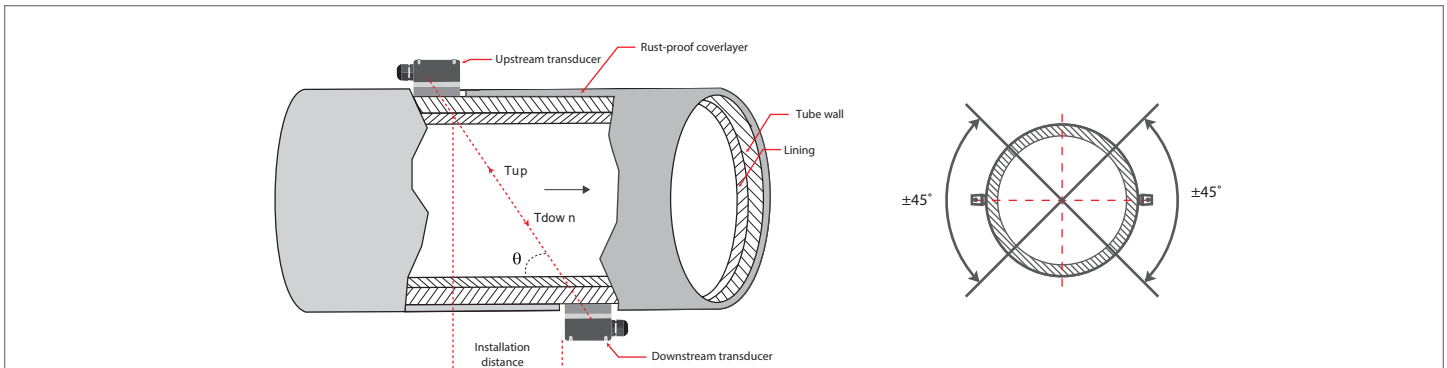

Fig 5: Z type Mountings of Tek-Clamp 1200A-100H Handheld Ultrasonic Flow Meter

The wider the pipe diameter, due to suspended particles, scaling thickens resulting in to weaker signal transmission in the V type mounting installation pulse without any reaction required, which is required in V method and therefore has less signal thinning.

W Method

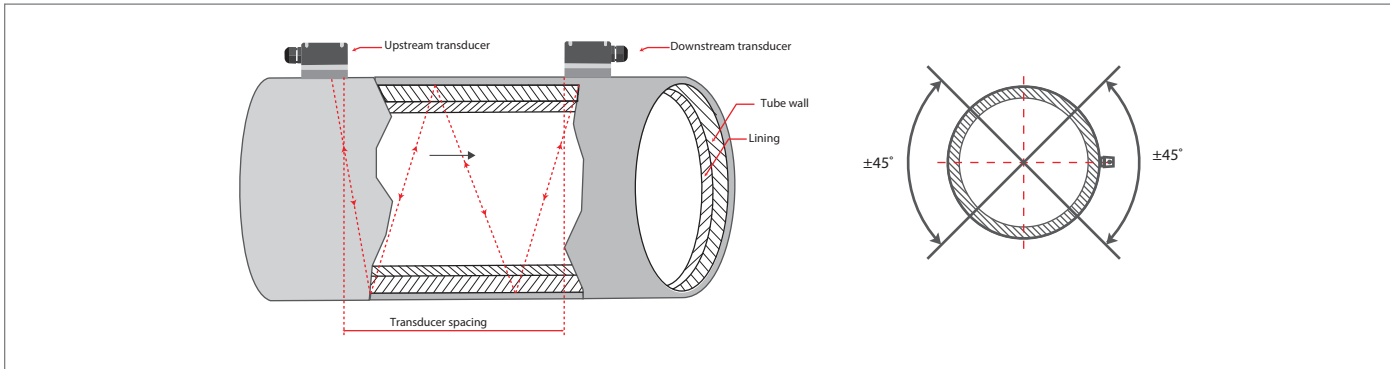

Fig 6: W type Mounting of Tek-Clamp 1200A-100H Handheld Ultrasonic Flow Meter

Normally, this type of mounting used when the material of pipe is plastic and had diameter of 10 millimeter to 100 millimeter.

5. Display



Fig 7: Display for Tek-Clamp 1200A-100H Handheld Ultrasonic Flow Meter

Quick Start Guide

6. Description

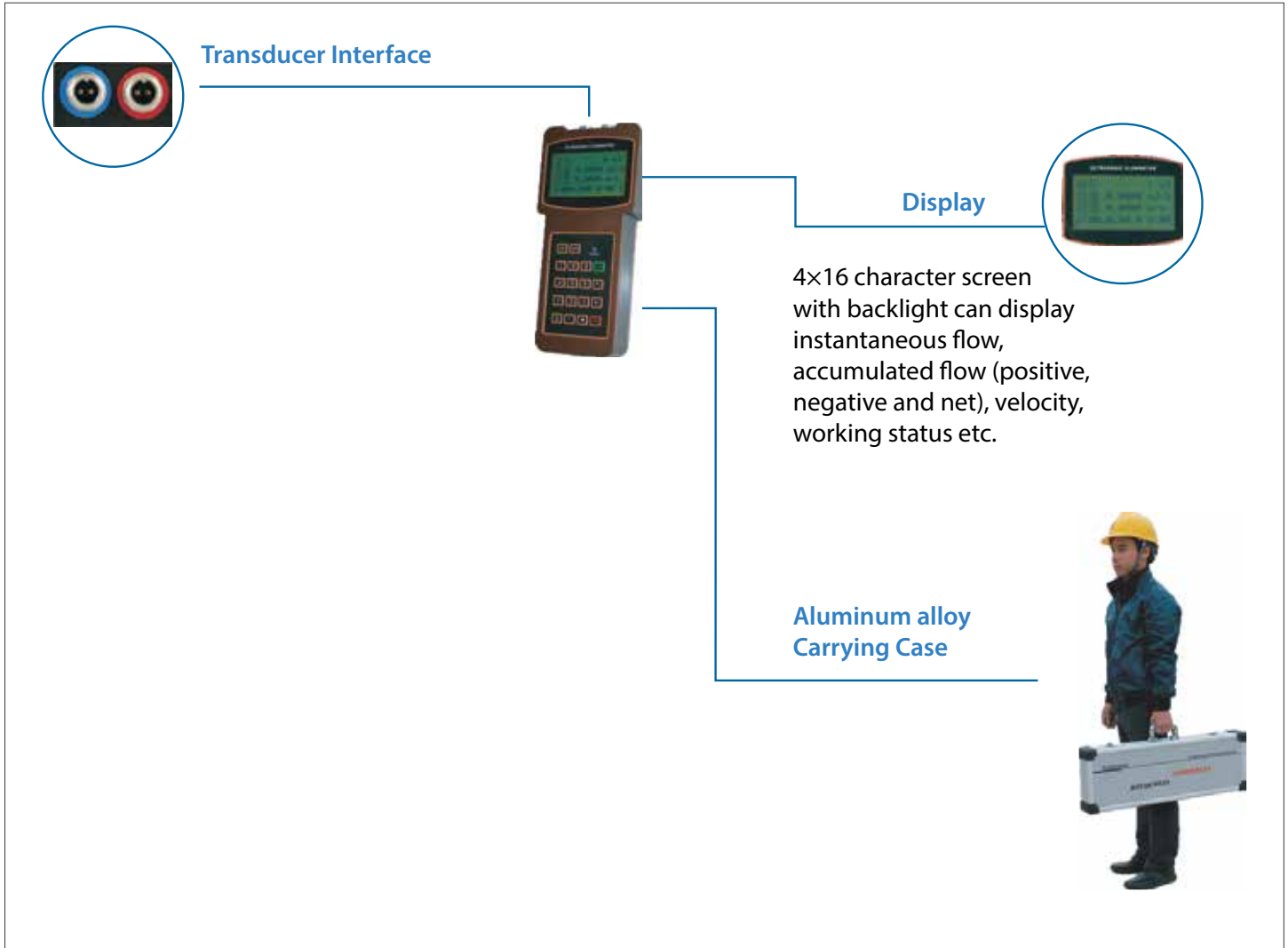

Fig 8: Description of parts of Tek-Clamp 1200A-100H Handheld Ultrasonic Flow Meter

7. Configuration

The Tek-Clamp 1200A-100H can be configured with the help of a 16 key keyboard monitor. Below, some of the keyboard uses are outlined:

- '0-9' and '.' are used to input numerical values and menu numbers receptively.
- '' key is used to left backspace or delete left characters.
- '</+>' and '</->' are used to shift to the Upper and Lower menu. When inputting the digits, these are equal to the "+" or "-" keys.
- The 'Menu' key brings up the main menu.
- The 'Enter' key is mainly used to ensure the digit and chosen content has been input the other function is to press it to enter and modify the status before setting parameters.

7. Installation of the Transducers

To ensure measurement accuracy and stability, the installation point of transducers should be on the straight pipe full of well-distributed fluid (when installing, the pipe must be full of liquid), and should follow the points below:

- The pipe must be full of uniform liquid that is easy for the ultrasonic pulse to travel through (vertical pipe or horizontal pipe).
- Avoid installing the transducer at the highest point of the pipe system or on the vertical pipe with free exit (down flow).

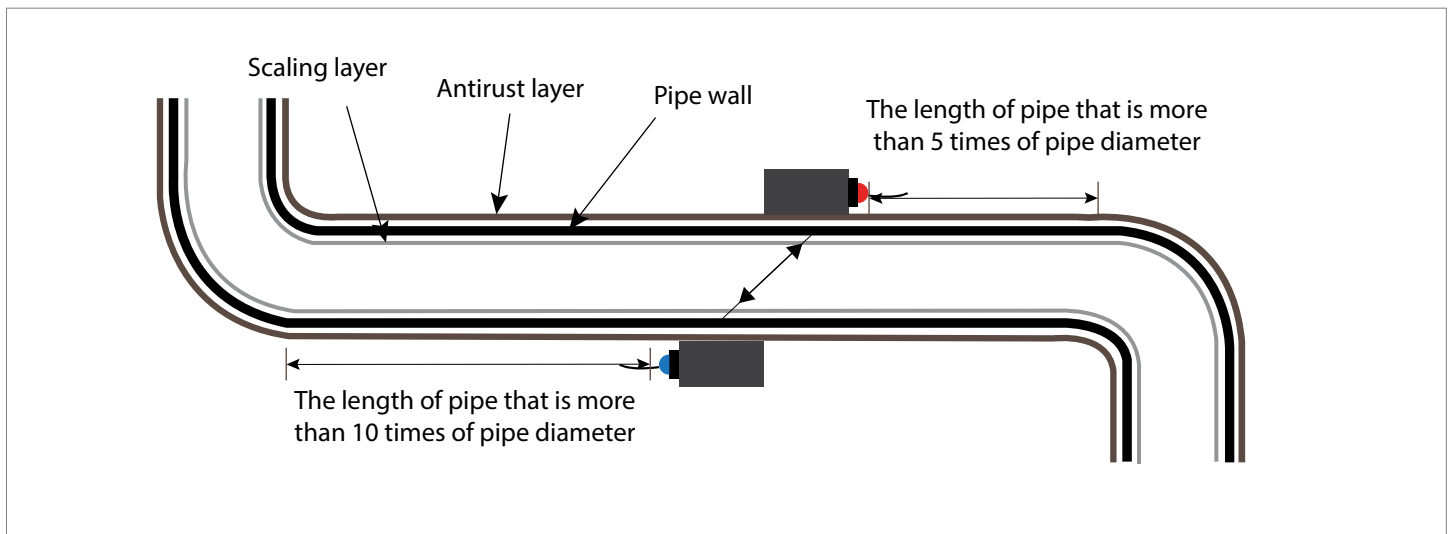

Fig 9: Installation on Horizontal pipe for Tek-Clamp 1200A-100H Handheld Ultrasonic Flow Meter .

Quick Start Guide

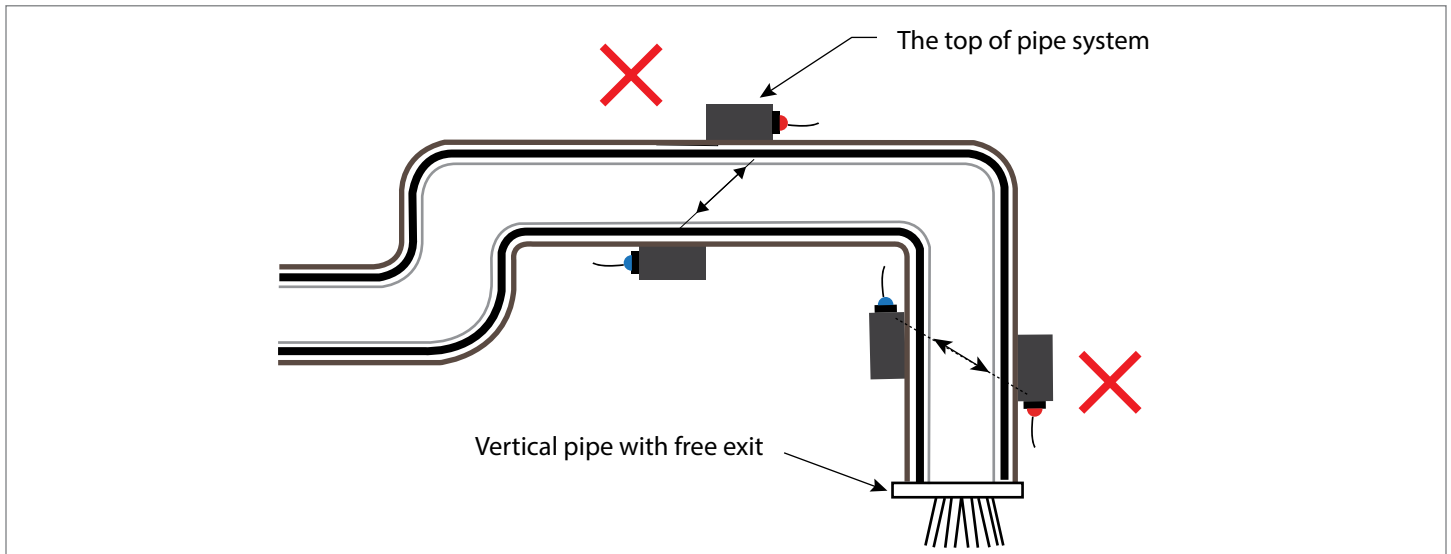

Fig 10: Incorrect mounting Vertical pipe for Tek-Clamp 1200A-100H Handheld Ultrasonic Flow Meter.

- For an open pipe or half full pipe, transducers should be installed at the bottom of the U pipe.

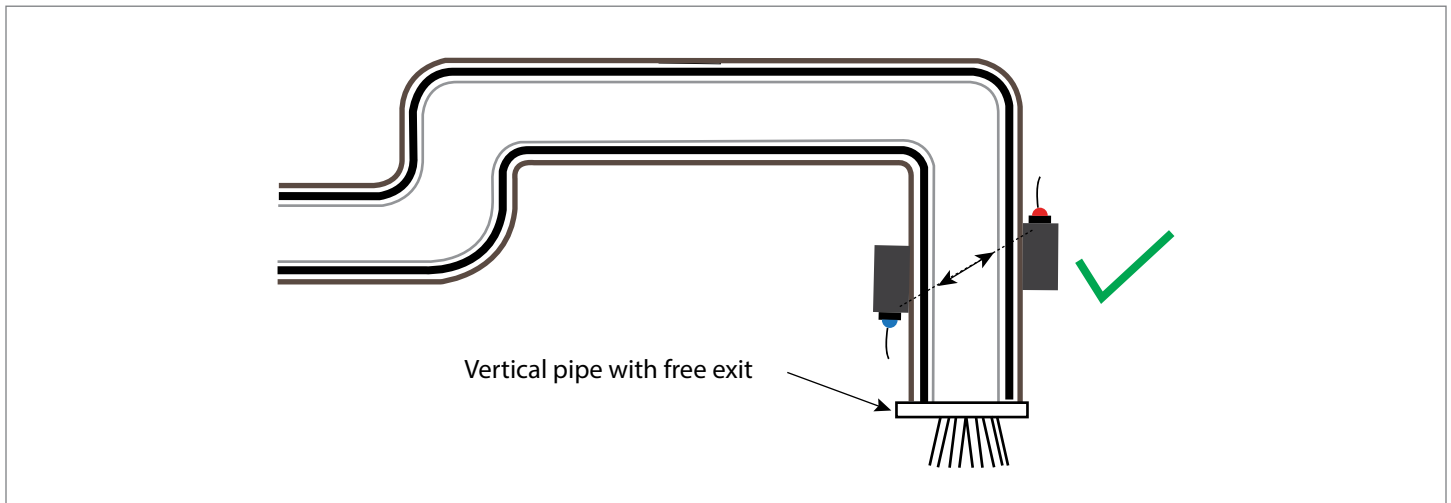
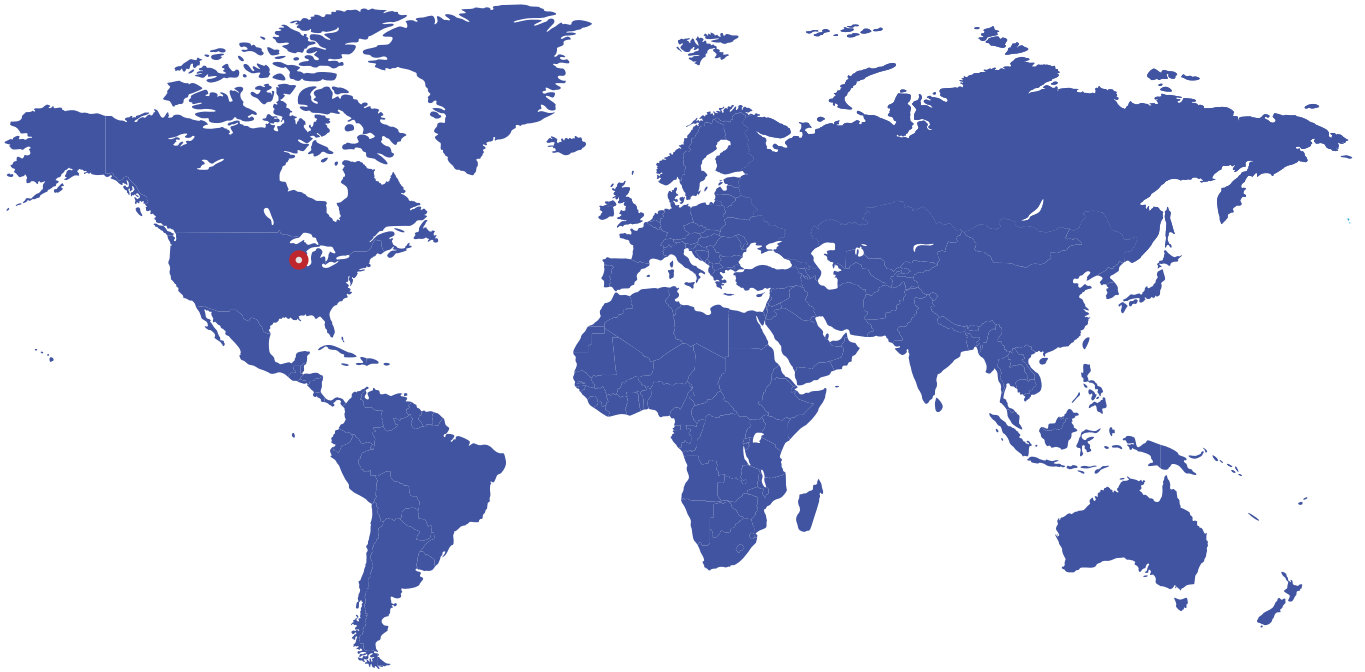



Fig 11: Correct mounting of vertical pipe for Tek-Clamp 1200A-100H Handheld Ultrasonic Flow Meter.

- The temperature and pressure on the installation point should be within the workability of the transducers.
- Please ensure the pipe's inner wall and check for pollution build-up. Select a pipe without any or very compact build-up of sediment because it may interfere with the signal.
- In cases of horizontal piping, mount the detector within $\pm 45^\circ$ of the horizontal plane. Otherwise, the measurement may be impossible if bubbles stay in the upper part of piping or if deposits are accumulate in the lower part of piping. In cases of vertical piping, the detector may be mounted at any position on it periphery provided that the flow is upward.



Tek-Trol LLC

796 Tek Drive Crystal Lake,
IL 60014, USA

 +1 847-857-6076

 tektrol@tek-trol.com

 www.tek-trol.com

Tek-Clamp 1200A-100H