



TEK-VOR 1300C ***Vortex Mass Flowmeter***

Instruction Manual

Document Number: IM-1300C



www.tek-trol.com

NOTICE

Read this manual before working with the product. For personal and system safety, and for optimum product performance, make sure you thoroughly understand the contents before installing, using, or maintaining this product.

For technical assistance, contact

Customer Support

796 Tek-Drive

Crystal Lake, IL 60014

USA

Tel: +1 847 857 6076

© COPYRIGHT Tek-Trol LLC 2021

No part of this publication may be copied or distributed, transmitted, transcribed, stored in a retrieval system, or translated into any human or computer language, in any form or by any means, electronic, mechanical, manual, or otherwise, or disclosed to third parties without the express written permission. The information contained in this manual is subject to change without notice.

Table of Contents

1	Safety Instructions.....	3
1.1	Intended Use	3
1.2	Certification	3
1.3	Safety Instructions from the Manufacturer.....	3
1.3.1	Disclaimer	3
1.3.2	Product Liability and Warranty.....	3
1.3.3	Information Concerning the Documentation	3
1.4	Safety Precautions	3
1.5	Packaging, Transportation and Storage	4
1.5.1	Packaging.....	4
1.5.2	Transportation	4
1.5.3	Storage.....	5
1.5.4	Nameplate	5
2	Product Description.....	6
2.1	Introduction.....	6
2.2	Measuring Principle	6
2.3	Specifications.....	8
2.4	Dimensional Drawings	9
2.5	Model Chart.....	17
3	Installation	19
3.1	General Notes on Installation	19
3.2	Safety Precautions	19
3.3	Installation Condition.....	20
4	Electrical Installation	23
4.1	Terminal Board	23
4.2	Wiring for a 5-Terminal Board	24
4.2.1	Wiring for a 3-Wire Pulse Output	24
4.2.2	Wiring for a 2-Wire HART with 4 to 20mA.....	25
4.2.3	Wiring for RS485.....	25
4.3	Wiring for a 12-Terminal Board	25
4.3.1	Wiring for a 3-Wire Pulse Output	25
4.3.2	Wiring for a 3-Wire HART with 4 to 20mA.....	26
4.3.3	Wiring for a 4-Wire HART with 4 to 20mA.....	27
4.3.4	Wiring for RS485.....	27
5	Operation.....	28
5.1	Display.....	28
5.1.1	Introduction to the Multi-Functional LCD Display	28
5.1.2	Units of the Variable Displayed	29
5.1.3	Three Button Setting	29
5.1.4	Total Flow Display.....	30
5.1.5	Modes.....	30
5.2	Parameter Setting.....	31
5.2.1	Code Setting	31
5.2.2	Digit Setting	32
5.2.3	Setting Address.....	33
5.2.4	Example of Setting.....	37
5.2.5	Password Setting Instruction	37
5.3	Communication using RS485 MODBUS.....	38
5.4	Bluetooth Access.....	44

5.4.1	How to download the application	44
5.4.2	Access the application	44
5.4.3	Utilize the application	44
6	Maintenance	45
6.1	How to Rotate Transmitter Head	45
6.2	Replace a Transmitter Circuit Board	45
6.3	Replace the Pressure Sensor	46
7	Troubleshooting	46
7.1	Troubleshooting Table	46
7.2	Self-Diagnostic Messages	48

1 Safety Instructions

1.1 Intended Use

Tek-Vor 1300C is primarily used to measure volumetric flow rate of gas, steam, and liquids. It is suitable for SIP and CIP process in food, beverage, and pharmaceutical industries. It is also used in water and wastewater industry.

The volumetric flow rate, temperature, pressure and density of any liquid, gas or steam are measured as an option. From these parameters, Tek-Vor 1300C can calculate the mass flow rate.

1.2 Certification

General purpose IP67/NEMA 4X

1.3 Safety Instructions from the Manufacturer

1.3.1 Disclaimer

The manufacturer will not be held accountable for any damage that happens by using its product, including, but not limited to direct, indirect, or incidental and consequential damages. Any product purchased from the manufacturer is warranted in accordance with the relevant product documentation and our Terms and Conditions of Sale.

The manufacturer has the right to modify the content of this document, including the disclaimer, at any time for any reason without prior notice, and will not be answerable in any way for the possible consequence of such changes.

1.3.2 Product Liability and Warranty

The operator shall bear authority for the suitability of the device for the specific application. The manufacturer accepts no liability for the consequences of misuse by the operator. Wrong installation or operation of the devices (systems) will cause the warranty to be void. The respective Terms and Conditions of Sale, which forms the basis for the sales contract shall also apply.

1.3.3 Information Concerning the Documentation

To prevent any injury to the operator or damage to the device it is essential to read the information in this document and the applicable national standard safety instructions. This operating manual contain all the information that is required in various stages, such as product identification, incoming acceptance and storage, mounting, connection, operation, and commissioning, troubleshooting, maintenance, and disposal.

1.4 Safety Precautions

You must read these instructions carefully prior to installing and commissioning the device. These instructions are an important part of the product and must be kept for future reference. Only by observing these instructions, optimum protection of both personnel and the environment, as well as safe and fault-free operation of the device can be ensured.

For additional information that are not discussed in this manual, contact the manufacturer

Warnings and Symbols Used

The following safety symbol marks are used in this operation manual and on the instrument.



WARNING

Indicates a potentially hazardous situation which, if not avoided, could result in death or serious injury



CAUTION

Indicates a potentially hazardous situation which, if not avoided, may result in minor or moderate injury. It may also be used to alert against unsafe practices.



NOTE

Indicates that operating the hardware or software in this manner may damage it or lead to system failure.

1.5 Packaging, Transportation and Storage

1.5.1 Packaging

The original package consists of

1. Tek-Vor 1300C Vortex Flowmeter
2. Documentation



NOTE

Unpack and check the contents for damages or signs of rough handling. Report damage to the manufacturer immediately. Check the contents against the packing list provided.

1.5.2 Transportation

- Avoid impact shocks to the device and prevent it from getting wet during transportation.

- Verify local safety regulations, directives, and company procedures with respect to hoisting, rigging, and transportation of heavy equipment.
- Transport the product to the installation site using the original manufacturer's packing whenever possible.

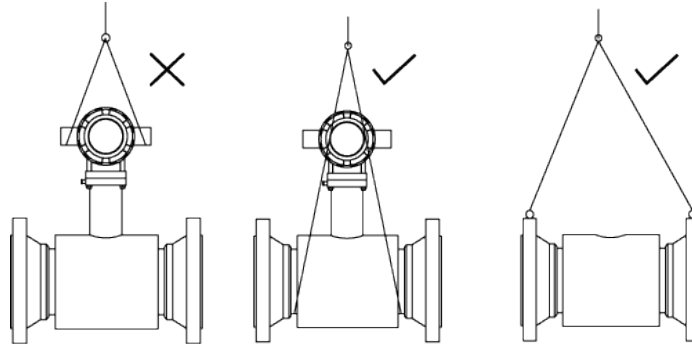

1.5.3 Storage

If this product is to be stored for a long period of time before installation, take the following precautions:

- Store your product in the manufacturer's original packing used for shipping.
- Storage location should conform to the following requirements:
 - Free from rain and water
 - Free from vibration and impact shock
 - At room temperature with minimal temperature and humidity variation
- Before storing a used flowmeter remove any fluid from the flowmeter line completely. Properties of the instrument can change when stored outdoors.

1.5.4 Nameplate

The nameplate lists the order number and other important information, such as design details and technical data



Note

Check the device nameplate to ensure that the device is delivered according to your order. Check for the correct supply voltage printed on the nameplate.

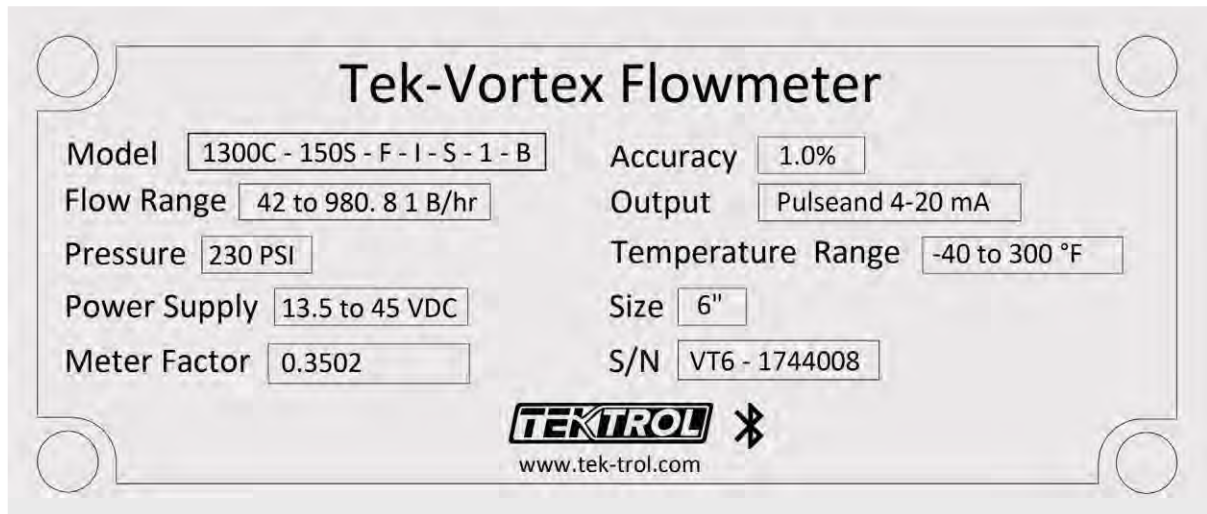

2 Product Description

This section covers the reference and specification data, as well as ordering information.

2.1 Introduction

Tek-Vor 1300C Vortex Flowmeter (also called a Vortex Shedding Flowmeter) is a versatile instrument that calculates the mass flow, volumetric flow rate, temperature, and pressure and density of any liquid, gas, or steam through a pipeline.

2.2 Measuring Principle

This flowmeter operates on the principle of Karman Vortex Street, any medium passing through the pipeline flows around the bluff body and sheds a series of alternating vortices on each side of the body. This phenomenon is referred to as Vortex Shedding. These vortices shed downstream of the bluff body and dissipate as they flow further. This pattern of vortices is called a Karman Vortex Street (also called a Von Karman Vortex Street).

A Vortex Flowmeter primarily consists of a bluff body, a sensor assembly, and a transmitter. A bluff body or a shedder is nothing but a non-streamlined object or a barrier placed perpendicular to the axis of the pipeline, around which the medium flows.

Calculation of volumetric flow rate

The frequency of the vortices, i.e., the number of vortices shed per second, is directly proportionate to the velocity of the medium. This Vortex Shedding Frequency is used to calculate the mass flow as well as the volume flow. The sensor assembly records the pressure and velocity oscillations generated on each side of the bluff body by the vortices and generate a digital linear output signal. The Vortex Shedding Frequency is calculated using the following formula:

$$f = S_t \times \frac{V}{d}$$

Where,

f = Frequency of Vortex Shedding

S_t = Strouhal Number
 V = Flow Velocity
 d = Width of the Bluff Body

The Vortex Shedding frequency is directly proportional to the velocity of any given bluff body diameter.

$$f = k \times V$$

Where,
 k = A constant for all fluids on the given design of flowmeter

Hence,

$$V = \frac{f}{k}$$

Then the volumetric flow rate can be calculated by using the formula:

$$q_v = A \times \frac{f}{k}$$

Where,
 A = Area of flowmeter bore



NOTE

Strouhal's Number is constant across a wide range of Reynold's number

2.3 Specifications

Nominal Diameter	½" to 12" (15 mm to 300 mm)		
Measurement Range in m/s (ft/sec)	Size	½" to 1"(15- 25mm)	1 1/2" to 12" (40 to 300mm)
	Fluid Flow Rate	Steam	13 to 230ft sec (4 to 70 m/sec)
		Gas	13 to 200ft sec (4 to 60m/sec)
		Liquid	1ft to 23ft sec (1 to 8m/sec)
Accuracy	±1% of Reading For Multivariable Version: Temperature ±1°F, Pressure: 0.75% FS		
Repeatability	0.3% of Reading		
Output	4 to 20mA and Pulse or 4 to 20mA with HART or RS485		
Maximum Process Pressure Limit	150# ANSI Flange, 300# ANSI Flange		
Process Temperature Range	-400F to 3000F (400C - 1500C) or 400F to 4800F (400C - 2500C) or 400F to 6600F (400C - 3500C)		
Ambient Humidity	5 to 100% RH		
Process Connection	Wafer, 150# ANSI Flange, 300# ANSI Flange		
Electrical Connection	½" NPT		
Material	304 SS, 316L SS		

2.4 Dimensional Drawings Size and Dimension for Wafer Type

Wafer Type 300°F

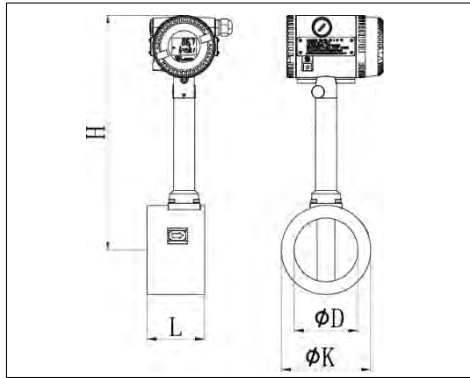

D	K	L	H
(Size) in. (mm)	(Pipe OD) in. (mm)	Meter height in.(mm)	Meter height in.(mm)
½"(15)	2.95"(75)	2.55"(65)	11.15"(283.5)
¾"(20)	2.95"(75)	2.55"(65)	11.05"(281)
1"(25)	2.95"(75)	2.55"(65)	10.95"(278.5)
1 ¼"(32)	3.15"(80)	2.55"(65)	11.15"(282.8)
1 ½"(40)	3.3"(84)	2.55"(65)	11.25"(285.8)
2"(50)	3.7"(94)	2.55"(65)	11.45"(291)
2 ½"(65)	4.15"(105)	2.55"(65)	11.75"(298.5)
3"(80)	4.7"(120)	2.55"(65)	12.05"(306)
4"(100)	5.5"(140)	3.55"(90)	12.5"(317)
5"(125)	6.5"(165)	2.55"(65)	13"(330.5)
6"(150)	7.5"(190)	2.55"(65)	13.5"(343)
8"(200)	9.45"(240)	3.35"(85)	14.5"(368)
10"(250)	11.4"(290)	3.95"(100)	15.5"(394)
12"(300)	13.4"(340)	4.7"(120)	16.5"(419)

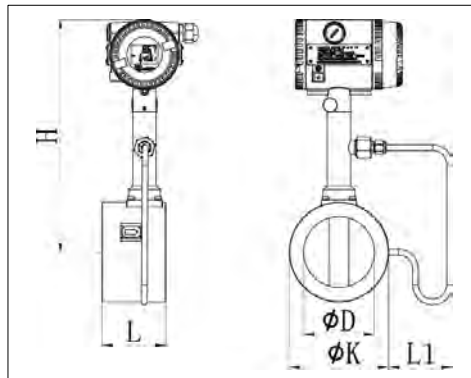

D	K	L	L1	H
(Size) in. (mm)	(Pipe OD) in. (mm)	Meter Height in.(mm)	Meter Height in.(mm)	Meter Height in.(mm)
½"(15)	2.95"(75)	2.55"(65)	3.4"(86)	11.15"(283.5)
¾"(20)	2.95"(75)	2.55"(65)	3.3"(83.5)	11.05"(281)
1"(25)	2.95"(75)	2.55"(65)	3.4"(86)	10.95"(278.5)
1 ¼"(32)	3.15"(80)	2.55"(65)	3.45"(87)	11.15"(282.8)
1 ½"(40)	3.3"(84)	2.55"(65)	3.5"(89)	11.25"(285.8)
2"(50)	3.7"(94)	2.55"(65)	3.5"(89)	11.45"(291)
2 ½"(65)	4.15"(105)	2.55"(65)	3.6"(91)	11.75"(298.5)
3"(80)	4.7"(120)	2.55"(65)	4.35"(111)	12.05"(306)
4"(100)	5.5"(140)	3.55"(90)	3.55"(90)	12.5"(317)
5"(125)	6.5"(165)	2.55"(65)	3.4"(86)	13"(330.5)
6"(150)	7.5"(190)	2.55"(65)	3.4"(86)	13.5"(343)
8"(200)	9.45"(240)	3.35"(85)	4.15"(106)	14.5"(368)
10"(250)	11.4"(290)	3.95"(100)	4.15"(106)	15.5"(394)
12"(300)	13.4"(340)	4.7"(120)	4.15"(106)	16.5"(419)

Wafer Type 480°F

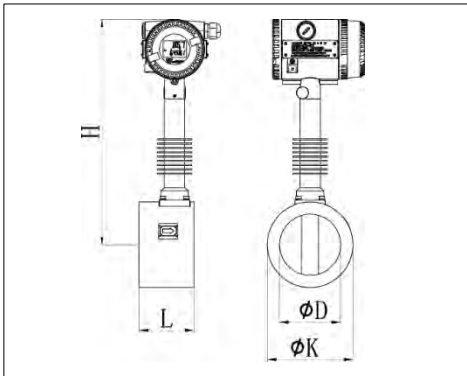

D	K	L	H
(Size) in. (mm)	(Pipe OD) in. (mm)	Meter height in.(mm)	Meter Height in.(mm)
½"(15)	2.95"(75)	2.55"(65)	13.15"(334.5)
¾"(20)	2.95"(75)	2.55"(65)	13.05"(332)
1"(25)	2.95"(75)	2.55"(65)	12.95"(329.5)
1 1/4 "(32)	3.15"(80)	2.55"(65)	13.15"(333.8)
1 ½ "(40)	3.3"(84)	2.55"(65)	13.25"(336.8)
2"(50)	3.7"(94)	2.55"(65)	13.45"(342)
2 ½ "(65)	4.15"(105)	2.55"(65)	13.75"(349.5)
3"(80)	4.7"(120)	2.55"(65)	14.05"(357)
4"(100)	5.5"(140)	3.55"(90)	14.5"(368)
5"(125)	6.5"(165)	2.55"(65)	15"(381.5)
6"(150)	7.5"(190)	2.55"(65)	21"(534)
8"(200)	9.45"(240)	3.35"(85)	22"(559)
10"(250)	11.4"(290)	3.95"(100)	23.05"(585)
12"(300)	13.4"(340)	4.7"(120)	24"(610)

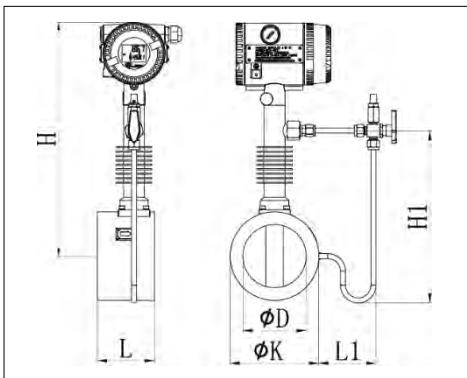

D	K	L	L1	H
(Size) in. (mm)	(Pipe OD) in. (mm)	Meter height in.(mm)	Meter height in.(mm)	Meter Height in.(mm)
½"(15)	2.95"(75)	2.55"(65)	3.4"(86)	13.15"(334.5)
¾"(20)	2.95"(75)	2.55"(65)	3.3"(83.5)	13.05"(332)
1"(25)	2.95"(75)	2.55"(65)	3.4"(86)	12.95"(329.5)
1 1/4 "(32)	3.15"(80)	2.55"(65)	3.45"(87)	13.15"(333.8)
1 ½ "(40)	3.3"(84)	2.55"(65)	3.5"(89)	13.25"(336.8)
2"(50)	3.7"(94)	2.55"(65)	3.5"(89)	13.45"(342)
2 ½ "(65)	4.15"(105)	2.55"(65)	3.6"(91)	13.75"(349.5)
3"(80)	4.7"(120)	2.55"(65)	4.35"(111)	14.05"(357)
4"(100)	5.5"(140)	3.55"(90)	3.55"(90)	14.5"(368)
5"(125)	6.5"(165)	2.55"(65)	3.4"(86)	15"(381.5)
6"(150)	7.5"(190)	2.55"(65)	3.4"(86)	21"(534)
8"(200)	9.45"(240)	3.35"(85)	4.15"(106)	22"(559)
10"(250)	11.4"(290)	3.95"(100)	4.15"(106)	23.05"(585)
12"(300)	13.4"(340)	4.7"(120)	4.15"(106)	24"(610)

Wafer Type 660°F

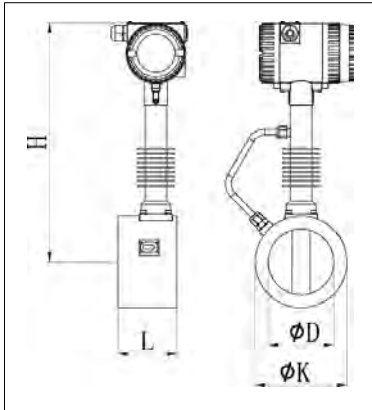

D (Size) in. (mm)	K (Pipe OD) in.(mm)	L Meter height in.(mm)	H Meter Height in.(mm)
½"(15)	2.95"(75)	2.55"(65)	18.7"(475)
¾ "(20)	2.95"(75)	2.55"(65)	18.7"(475)
1"(25)	2.95"(75)	2.55"(65)	18.7"(475)
1 ¼ "(32)	3.15"(80)	2.55"(65)	18.7"(475)
1 ½ "(40)	3.3"(84)	2.55"(65)	18.7"(475)
2"(50)	3.7"(94)	2.55"(65)	19"(482)
2 ½ "(65)	4.15"(105)	2.55"(65)	19.3"(490)
3"(80)	4.7"(120)	2.55"(65)	19.55"(497)
4"(100)	5.5"(140)	3.55"(90)	20"(508)
5"(125)	6.5"(165)	2.55"(65)	20.5"(521)
6"(150)	7.5"(190)	2.55"(65)	21"(534)
8"(200)	9.45"(240)	3.35"(85)	22"(559)
10"(250)	11.4"(290)	3.95"(100)	23.05"(585)
12"(300)	13.4"(340)	4.7"(120)	24"(610)

Neck Flange (300°F)

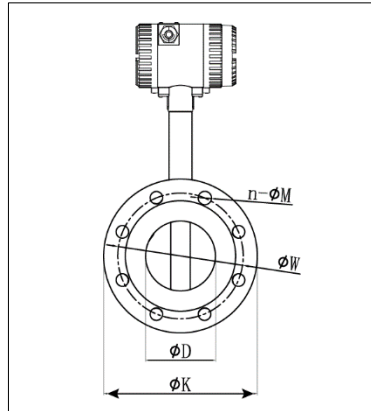

ANSI / ASME – CLASS 150

D (Size) in. (mm)	K (Pipe OD) in. (mm)	W Flange screw hole distance in. (mm)	C (Flange thickness) in.(mm)	n-ØM (Bolt hole diameter) in.(mm)	H Meter height in.(mm)	N Bolt qty
½"(15)	3.55"(90)	2.35"(60.3)	0.45"(11.6)	0.65"(15.9)	11.55"(294)	4
¾"(20)	3.95"(100)	2.75"(69.9)	0.5"(13.2)	0.65"(15.9)	11.55"(294)	4
1"(25)	4.35"(110)	3.15"(79.4)	0.6"(14.7)	0.65"(15.9)	11.55"(294)	4
1 ¼"(32)	4.6"(117.3)	3.5"(88.9)	0.65"(16.3)	0.65"(15.9)	11.55"(294)	4
1 ½"(40)	5"(127)	3.85"(98.4)	0.7"(17.9)	0.65"(15.9)	11.65"(296)	4
2"(50)	6"(152.4)	4.75"(120.7)	0.75"(19.5)	0.75"(19)	11.85"(301)	4
2 ½"(65)	7.1"(180)	5.5"(139.7)	0.9"(22.7)	0.75"(19)	12.15"(309)	4
3"(80)	7.5"(190.5)	6"(152.4)	0.95"(24.3)	0.75"(19)	12.45"(316)	4
4"(100)	9.05"(230)	7.5"(190.5)	0.95"(24.3)	0.75"(19)	12.85"(327)	8
5"(125)	10.05"(255)	8.5"(215.9)	0.95"(24.3)	0.85"(22.2)	13.45"(341)	8
6"(150)	11"(280)	9.5"(241.3)	1"(25.9)	0.85"(22.2)	13.9"(353)	8
8"(200)	13.6"(345)	11.75"(298.5)	1.15"(29)	0.85"(22.2)	14.9"(378)	8
10"(250)	16"(406.4)	14.25"(362)	1.2"(30.6)	1"(25.4)	15.9"(404)	12
12"(300)	19.1"(485)	17"(431.8)	1.25"(32.2)	1"(25.4)	16.9"(429)	12

ANSI / ASME – CLASS 300

D (Size) in. (mm)	K (Pipe OD) in. (mm)	W Flange screw hole distance in. (mm)	C (Flange thickness) in.(mm)	n-ØM (Bolt hole diameter) in.(mm)	H Meter height in.(mm)	N Bolt qty
½"(15)	3.75"(95.2)	2.65"(66.7)	0.6"(14.7)	0.65"(15.9)	11.55"(294)	4
¾"(20)	4.65"(117.5)	3.25"(82.6)	0.65"(16.3)	0.75"(19)	11.55"(294)	4
1"(25)	4.9"(125)	3.5"(88.9)	0.7"(17.9)	0.75"(19)	11.55"(294)	4
1 ¼"(32)	5.3"(135)	3.85"(98.4)	0.75"(19.5)	0.75"(19)	11.55"(294)	4
1 ½"(40)	6.15"(156)	4.5"(114.3)	0.85"(21.1)	0.85"(22.2)	11.65"(296)	4
2"(50)	6.5"(165.1)	5"(127)	0.9"(22.7)	0.75"(19)	11.85"(301)	8
2 ½"(65)	7.5"(191)	5.85"(149.2)	1"(25.9)	1"(25.9)	12.15"(309)	8
3"(80)	8.25"(210)	6.65"(168.3)	1.15"(29)	1.15"(29)	12.45"(316)	8
4"(100)	10.05"(255)	7.85"(200)	1.25"(32.2)	1.25"(32.2)	12.85"(327)	8
5"(125)	11"(280)	9.25"(235)	1.4"(35.4)	1.4"(35.4)	13.45"(341)	8
6"(150)	12.6"(320)	10.65"(269.9)	1.45"(37)	1.45"(37)	13.9"(353)	12
8"(200)	15"(381)	13"(330.2)	1.65"(41.7)	1.65"(41.7)	14.9"(378)	12
10"(250)	17.5"(445)	15.25"(387.4)	1.9"(48.1)	1.9"(48.1)	15.9"(404)	16
12"(300)	20.5"(521)	17.75"(450.8)	2"(51.3)	2"(51.3)	16.9"(429)	16

Neck Flange (300°F)

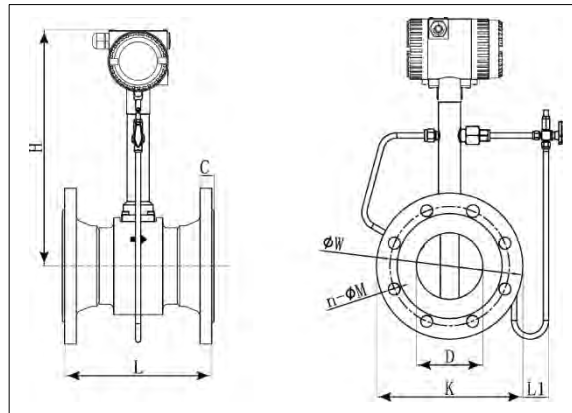

ANSI / ASME - CLASS 150

D	K	W	C	n-ØM	L1	H	N
(Size) in. (mm)	(Pipe OD) in. (mm)	Flange screw hole distance in. (mm)	(Flange thickness) in.(mm)	(Bolt hole diameter) in.(mm)	Meter Height in.(mm)	Meter height in.(mm)	Bolt qty
½"(15)	3.55"(90)	2.35"(60.3)	0.45"(11.6)	0.65"(15.9)	2.9"(73.5)	11.55"(294)	4
¾"(20)	3.95"(100)	2.75"(69.9)	0.5"(13.2)	0.65"(15.9)	2.6"(66)	11.55"(294)	4
1"(25)	4.35"(110)	3.15"(79.4)	0.6"(14.7)	0.65"(15.9)	2.5"(63.5)	11.55"(294)	4
1 ¼"(32)	4.6"(117.3)	3.5"(88.9)	0.65"(16.3)	0.65"(15.9)	2.7"(68)	11.55"(294)	4
1 ½"(40)	5"(127)	3.85"(98.4)	0.7"(17.9)	0.65"(15.9)	2.65"(67.5)	11.65"(296)	4
2"(50)	6"(152.4)	4.75"(120.7)	0.75"(19.5)	0.75"(19)	2.4"(61)	11.85"(301)	4
2 ½"(65)	7.1"(180)	5.5"(139.7)	0.9"(22.7)	0.75"(19)	1.9"(48.5)	12.15"(309)	4
3"(80)	7.5"(190.5)	6"(152.4)	0.95"(24.3)	0.75"(19)	1.8"(46)	12.45"(316)	4
4"(100)	9.05"(230)	7.5"(190.5)	0.95"(24.3)	0.75"(19)	1.55"(40)	12.85"(327)	8
5"(125)	10.05"(255)	8.5"(215.9)	0.95"(24.3)	0.85"(22.2)	1.6"(41)	13.45"(341)	8
6"(150)	11"(280)	9.5"(241.3)	1"(25.9)	0.85"(22.2)	1.4"(36)	13.9"(353)	8
8"(200)	13.6"(345)	11.75"(298.5)	1.15"(29)	0.85"(22.2)	2.1"(53.5)	14.9"(378)	8
10"(250)	16"(406.4)	14.25"(362)	1.2"(30.6)	1"(25.4)	1.9"(48)	15.9"(404)	12
12"(300)	19.1"(485)	17"(431.8)	1.25"(32.2)	1"(25.4)	1.55"(39.5)	16.9"(429)	12

ANSI / ASME – CLASS 300

D	K	W	C	n-ØM	L1	H	N
(Size) in. (mm)	(Pipe OD) in. (mm)	Flange screw hole distance in. (mm)	(Flange thickness) in.(mm)	(Bolt hole diameter) in.(mm)	Meter Height in.(mm)	Meter height in.(mm)	Bolt qty
½"(15)	3.75"(95.2)	2.65"(66.7)	0.6"(14.7)	0.65"(15.9)	2.8"(71)	11.55"(294)	4
¾"(20)	4.65"(117.5)	3.25"(82.6)	0.65"(16.3)	0.75"(19)	2.25"(57.2)	11.55"(294)	4
1"(25)	4.9"(125)	3.5"(88.9)	0.7"(17.9)	0.75"(19)	2"(51)	11.55"(294)	4
1 ¼"(32)	5.3"(135)	3.85"(98.4)	0.75"(19.5)	0.75"(19)	2.3"(59)	11.55"(294)	4
1 ½"(40)	6.15"(156)	4.5"(114.3)	0.85"(21.1)	0.85"(22.2)	2.1"(53)	11.65"(296)	4
2"(50)	6.5"(165.1)	5"(127)	0.9"(22.7)	0.75"(19)	2.15"(54.7)	11.85"(301)	8
2 ½"(65)	7.5"(191)	5.85"(149.2)	1"(25.9)	1"(25.9)	1.7"(43)	12.15"(309)	8
3"(80)	8.25"(210)	6.65"(168.3)	1.15"(29)	1.15"(29)	1.45"(36.3)	12.45"(316)	8
4"(100)	10.05"(255)	7.85"(200)	1.25"(32.2)	1.25"(32.2)	1.1"(28.5)	12.85"(327)	8
5"(125)	11"(280)	9.25"(235)	1.4"(35.4)	1.4"(35.4)	1.1"(28.5)	13.45"(341)	8
6"(150)	12.6"(320)	10.65"(269.9)	1.45"(37)	1.45"(37)	0.65"(16)	13.9"(353)	12
8"(200)	15"(381)	13"(330.2)	1.65"(41.7)	1.65"(41.7)	1.4"(35.5)	14.9"(378)	12
10"(250)	17.5"(445)	15.25"(387.4)	1.9"(48.1)	1.9"(48.1)	1.15"(28.7)	15.9"(404)	16
12"(300)	20.5"(521)	17.75"(450.8)	2"(51.3)	2"(51.3)	0.85"(21.5)	16.9"(429)	16

Neck Flange 480°F

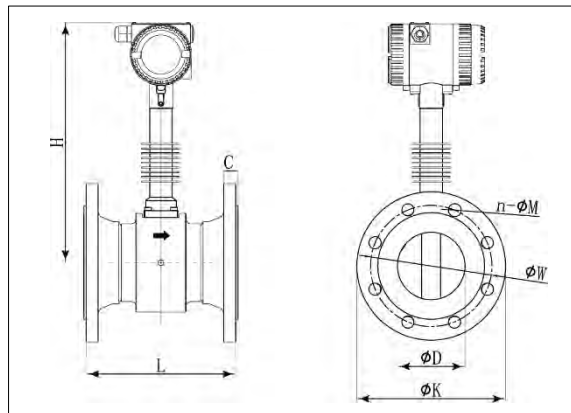

ANSI / ASME – CLASS 150

D	K	W	C	Ø-M	H	N
(Size) in. (mm)	(Pipe OD) in. (mm)	Flange screw hole distance in. (mm)	(Flange thickness) in.(mm)	(Bolt hole diameter) in.(mm)	Meter height in.(mm)	Boltqty
½"(15)	3.55"(90)	2.35"(60.3)	0.45"(11.6)	0.65"(15.9)	13.2"(335)	4
¾"(20)	3.95"(100)	2.75"(69.9)	0.5"(13.2)	0.65"(15.9)	13.2"(335)	4
1"(25)	4.35"(110)	3.15"(79.4)	0.6"(14.7)	0.65"(15.9)	13.2"(335)	4
1 ¼"(32)	4.6"(117.3)	3.5"(88.9)	0.65"(16.3)	0.65"(15.9)	13.2"(335)	4
1 ½"(40)	5"(127)	3.85"(98.4)	0.7"(17.9)	0.65"(15.9)	13.25"(337)	4
2"(50)	6"(152.4)	4.75"(120.7)	0.75"(19.5)	0.75"(19)	13.45"(342)	4
2 ½"(65)	7.1"(180)	5.5"(139.7)	0.9"(22.7)	0.75"(19)	13.8"(350)	4
3"(80)	7.5"(190.5)	6"(152.4)	0.95"(24.3)	0.75"(19)	14.05"(357)	4
4"(100)	9.05"(230)	7.5"(190.5)	0.95"(24.3)	0.75"(19)	14.5"(368)	8
5"(125)	10.05"(255)	8.5"(215.9)	0.95"(24.3)	0.85"(22.2)	15.05"(382)	8
6"(150)	11"(280)	9.5"(241.3)	1"(25.9)	0.85"(22.2)	21"(534)	8
8"(200)	13.6"(345)	11.75"(298.5)	1.15"(29)	0.85"(22.2)	22"(559)	8
10"(250)	16"(406.4)	14.25"(362)	1.2"(30.6)	1"(25.4)	23.05"(585)	12
12"(300)	19.1"(485)	17"(431.8)	1.25"(32.2)	1"(25.4)	24"(610)	12

ANSI / ASME – CLASS 300

D	K	W	C	Ø-M	H	N
(Size) in. (mm)	(Pipe OD) in. (mm)	Flange screw hole distance in. (mm)	(Flange thickness) in.(mm)	(Bolt hole diameter) in.(mm)	Meter height in.(mm)	Bolt qty
½"(15)	3.75"(95.2)	2.65"(66.7)	0.6"(14.7)	0.65"(15.9)	18.7"(475)	4
¾"(20)	4.65"(117.5)	3.25"(82.6)	0.65"(16.3)	0.75"(19)	18.7"(475)	4
1"(25)	4.9"(125)	3.5"(88.9)	0.7"(17.9)	0.75"(19)	18.7"(475)	4
1 ¼"(32)	5.3"(135)	3.85"(98.4)	0.75"(19.5)	0.75"(19)	18.7"(475)	4
1 ½"(40)	6.15"(156)	4.5"(114.3)	0.85"(21.1)	0.85"(22.2)	18.8"(477)	4
2"(50)	6.5"(165.1)	5"(127)	0.9"(22.7)	0.75"(19)	19"(482)	8
2 ½"(65)	7.5"(191)	5.85"(149.2)	1"(25.9)	1"(25.9)	19.3"(490)	8
3"(80)	8.25"(210)	6.65"(168.3)	1.15"(29)	1.15"(29)	19.55"(497)	8
4"(100)	10.05"(255)	7.85"(200)	1.25"(32.2)	1.25"(32.2)	20"(508)	8
5"(125)	11"(280)	9.25"(235)	1.4"(35.4)	1.4"(35.4)	20.55"(522)	8
6"(150)	12.6"(320)	10.65"(269.9)	1.45"(37)	1.45"(37)	21"(534)	12
8"(200)	15"(381)	13"(330.2)	1.65"(41.7)	1.65"(41.7)	22"(559)	12
10"(250)	17.5"(445)	15.25"(387.4)	1.9"(48.1)	1.9"(48.1)	23.05"(585)	16
12"(300)	20.5"(521)	17.75"(450.8)	2"(51.3)	2"(51.3)	24"(610)	16

Neck Flange (480°F)

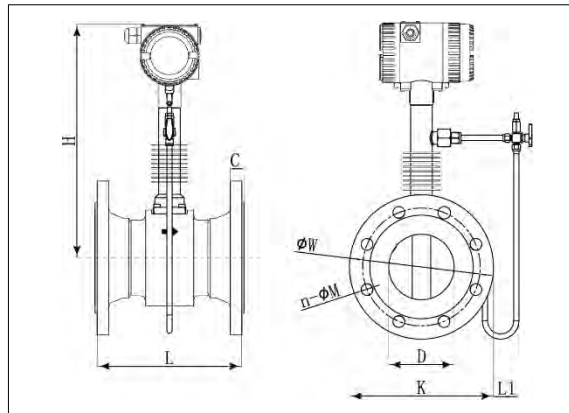

ANSI / ASME – CLASS 150

D	K	W	C	Ø-M	H	L1	N
(Size) in. (mm)	(Pipe OD) in. (mm)	Flange screw hole distance in. (mm)	(Flange thickness) in.(mm)	(Bolt hole diameter) in.(mm)	Meter Height in.(mm)	Pipe length in.(mm)	Bolt qty
½"(15)	3.55"(90)	2.35"(60.3)	0.45"(11.6)	0.65"(15.9)	13.2"(335)	2.9"(73.5)	4
¾"(20)	3.95"(100)	2.75"(69.9)	0.5"(13.2)	0.65"(15.9)	13.2"(335)	2.6"(66)	4
1"(25)	4.35"(110)	3.15"(79.4)	0.6"(14.7)	0.65"(15.9)	13.2"(335)	2.5"(63.5)	4
1 ¼"(32)	4.6"(117.3)	3.5"(88.9)	0.65"(16.3)	0.65"(15.9)	13.2"(335)	2.7"(68)	4
1 ½"(40)	5"(127)	3.85"(98.4)	0.7"(17.9)	0.65"(15.9)	13.25"(337)	2.65"(67.5)	4
2"(50)	6"(152.4)	4.75"(120.7)	0.75"(19.5)	0.75"(19)	13.45"(342)	2.4"(61)	4
2 ½"(65)	7.1"(180)	5.5"(139.7)	0.9"(22.7)	0.75"(19)	13.8"(350)	1.9"(48.5)	4
3"(80)	7.5"(190.5)	6"(152.4)	0.95"(24.3)	0.75"(19)	14.05"(357)	1.8"(46)	4
4"(100)	9.05"(230)	7.5"(190.5)	0.95"(24.3)	0.75"(19)	14.5"(368)	1.55"(40)	8
5"(125)	10.05"(255)	8.5"(215.9)	0.95"(24.3)	0.85"(22.2)	15.05"(382)	1.6"(41)	8
6"(150)	11"(280)	9.5"(241.3)	1"(25.9)	0.85"(22.2)	21"(534)	1.4"(36)	8
8"(200)	13.6"(345)	11.75"(298.5)	1.15"(29)	0.85"(22.2)	22"(559)	2.1"(53.5)	8
10"(250)	16"(406.4)	14.25"(362)	1.2"(30.6)	1"(25.4)	23.05"(585)	1.9"(48)	12
12"(300)	19.1"(485)	17"(431.8)	1.25"(32.2)	1"(25.4)	24"(610)	1.55"(39.5)	12

ANSI / ASME – CLASS 300

D	K	W	C	Ø-M	H	L1	N
(Size) in. (mm)	(Pipe OD) in. (mm)	Flange screw hole distance in. (mm)	(Flange thickness) in.(mm)	(Bolt hole diameter) in.(mm)	Meter Height in.(mm)	Pipe length in.(mm)	Bolt qty
½"(15)	3.75"(95.2)	2.65"(66.7)	0.6"(14.7)	0.65"(15.9)	13.2"(335)	2.8"(71)	4
¾"(20)	4.65"(117.5)	3.25"(82.6)	0.65"(16.3)	0.75"(19)	13.2"(335)	2.25"(57.2)	4
1"(25)	4.9"(125)	3.5"(88.9)	0.7"(17.9)	0.75"(19)	13.2"(335)	2"(51)	4
1 ¼"(32)	5.3"(135)	3.85"(98.4)	0.75"(19.5)	0.75"(19)	13.2"(335)	2.3"(59)	4
1 ½"(40)	6.15"(156)	4.5"(114.3)	0.85"(21.1)	0.85"(22.2)	13.25"(337)	2.1"(53)	4
2"(50)	6.5"(165.1)	5"(127)	0.9"(22.7)	0.75"(19)	13.45"(342)	2.15"(54.7)	8
2 ½"(65)	7.5"(191)	5.85"(149.2)	1"(25.9)	1"(25.9)	13.8"(350)	1.7"(43)	8
3"(80)	8.25"(210)	6.65"(168.3)	1.15"(29)	1.15"(29)	14.05"(357)	1.45"(36.3)	8
4"(100)	10.05"(255)	7.85"(200)	1.25"(32.2)	1.25"(32.2)	14.5"(368)	1.1"(28.5)	8
5"(125)	11"(280)	9.25"(235)	1.4"(35.4)	1.4"(35.4)	15.05"(382)	1.1"(28.5)	8
6"(150)	12.6"(320)	10.65"(269.9)	1.45"(37)	1.45"(37)	21"(534)	0.65"(16)	12
8"(200)	15"(381)	13"(330.2)	1.65"(41.7)	1.65"(41.7)	22"(559)	1.4"(35.5)	12
10"(250)	17.5"(445)	15.25"(387.4)	1.9"(48.1)	1.9"(48.1)	23.05"(585)	1.15"(28.7)	16
12"(300)	20.5"(521)	17.75"(450.8)	2"(51.3)	2"(51.3)	24"(610)	0.85"(21.5)	16

Neck Flange (660°F)

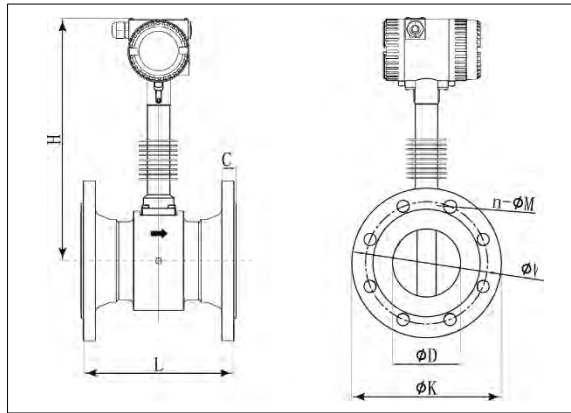

ANSI / ASME – CLASS 150

D	K	W	C	Ø-M	H	N
(Size) in. (mm)	(Pipe OD) in. (mm)	Flange screw hole distance in. (mm)	(Flange thickness) in.(mm)	(Bolt hole diameter) in.(mm)	Meter height in.(mm)	Bolt qty
½"(15)	3.55"(90)	2.35"(60.3)	0.45"(11.6)	0.65"(15.9)	18.7"(475)	4
¾"(20)	3.95"(100)	2.75"(69.9)	0.5"(13.2)	0.65"(15.9)	18.7"(475)	4
1"(25)	4.35"(110)	3.15"(79.4)	0.6"(14.7)	0.65"(15.9)	18.7"(475)	4
1 ¼"(32)	4.6"(117.3)	3.5"(88.9)	0.65"(16.3)	0.65"(15.9)	18.7"(475)	4
1 ½"(40)	5"(127)	3.85"(98.4)	0.7"(17.9)	0.65"(15.9)	18.8"(477)	4
2"(50)	6"(152.4)	4.75"(120.7)	0.75"(19.5)	0.75"(19)	19"(482)	4
2 ½"(65)	7.1"(180)	5.5"(139.7)	0.9"(22.7)	0.75"(19)	19.3"(490)	4
3"(80)	7.5"(190.5)	6"(152.4)	0.95"(24.3)	0.75"(19)	19.55"(497)	4
4"(100)	9.05"(230)	7.5"(190.5)	0.95"(24.3)	0.75"(19)	20"(508)	8
5"(125)	10.05"(255)	8.5"(215.9)	0.95"(24.3)	0.85"(22.2)	20.55"(522)	8
6"(150)	11"(280)	9.5"(241.3)	1"(25.9)	0.85"(22.2)	21"(534)	8
8"(200)	13.6"(345)	11.75"(298.5)	1.15"(29)	0.85"(22.2)	22"(559)	8
10"(250)	16"(406.4)	14.25"(362)	1.2"(30.6)	1"(25.4)	23.05"(585)	12
12"(300)	19.1"(485)	17"(431.8)	1.25"(32.2)	1"(25.4)	24"(610)	12

ANSI / ASME – CLASS 300

D	K	W	C	Ø-M	H	N
(Size) in. (mm)	(Pipe OD) in. (mm)	Flange screw hole distance in. (mm)	(Flange thickness) in.(mm)	(Bolt hole diameter) in.(mm)	Meter height in.(mm)	Bolt qty
½"(15)	3.75"(95.2)	2.65"(66.7)	0.6"(14.7)	0.65"(15.9)	18.7"(475)	4
¾"(20)	4.65"(117.5)	3.25"(82.6)	0.65"(16.3)	0.75"(19)	18.7"(475)	4
1"(25)	4.9"(125)	3.5"(88.9)	0.7"(17.9)	0.75"(19)	18.7"(475)	4
1 ¼"(32)	5.3"(135)	3.85"(98.4)	0.75"(19.5)	0.75"(19)	18.7"(475)	4
1 ½"(40)	6.15"(156)	4.5"(114.3)	0.85"(21.1)	0.85"(22.2)	18.8"(477)	4
2"(50)	6.5"(165.1)	5"(127)	0.9"(22.7)	0.75"(19)	19"(482)	8
2 ½"(65)	7.5"(191)	5.85"(149.2)	1"(25.9)	1"(25.4)	19.3"(490)	8
3"(80)	8.25"(210)	6.65"(168.3)	1.15"(29)	1.15"(29)	19.55"(497)	8
4"(100)	10.05"(255)	7.85"(200)	1.25"(32.2)	1.25"(32.2)	20"(508)	8
5"(125)	11"(280)	9.25"(235)	1.4"(35.4)	1.4"(35.4)	20.55"(522)	8
6"(150)	12.6"(320)	10.65"(269.9)	1.45"(37)	1.45"(37)	21"(534)	12
8"(200)	15"(381)	13"(330.2)	1.65"(41.7)	1.65"(41.7)	22"(559)	12
10"(250)	17.5"(445)	15.25"(387.4)	1.9"(48.1)	1.9"(48.1)	23.05"(585)	16
12"(300)	20.5"(521)	17.75"(450.8)	2"(51.3)	2"(51.3)	24"(610)	16

Neck Flange (660°F)

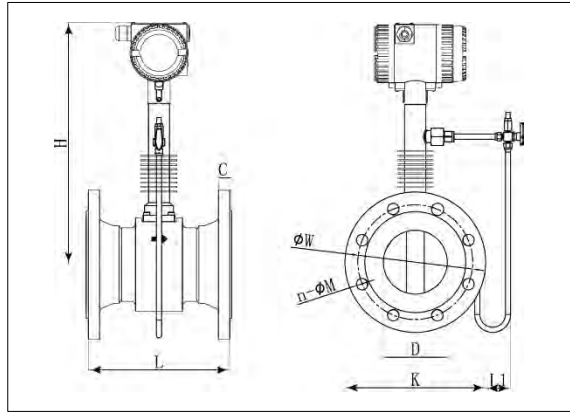

ANSI / ASME – CLASS 150

D (Size) in. (mm)	K (Pipe OD) in. (mm)	W Flange screw hole distance in. (mm)	C (Flange thickness) in.(mm)	Ø-M (Bolt hole diameter) in.(mm)	H Meter Height in.(mm)	L1 Pipe length in.(mm)	N Bolt qty
½"(15)	3.55"(90)	2.35"(60.3)	0.45"(11.6)	0.65"(15.9)	18.7"(475)	2.9"(73.5)	4
¾"(20)	3.95"(100)	2.75"(69.9)	0.5"(13.2)	0.65"(15.9)	18.7"(475)	2.6"(66)	4
1"(25)	4.35"(110)	3.15"(79.4)	0.6"(14.7)	0.65"(15.9)	18.7"(475)	2.5"(63.5)	4
1 ¼"(32)	4.6"(117.3)	3.5"(88.9)	0.65"(16.3)	0.65"(15.9)	18.7"(475)	2.7"(68)	4
1 ½"(40)	5"(127)	3.85"(98.4)	0.7"(17.9)	0.65"(15.9)	18.8"(477)	2.65"(67.5)	4
2"(50)	6"(152.4)	4.75"(120.7)	0.75"(19.5)	0.75"(19)	19"(482)	2.4"(61)	4
2 ½"(65)	7.1"(180)	5.5"(139.7)	0.9"(22.7)	0.75"(19)	19.3"(490)	1.9"(48.5)	4
3"(80)	7.5"(190.5)	6"(152.4)	0.95"(24.3)	0.75"(19)	19.55"(497)	1.8"(46)	4
4"(100)	9.05"(230)	7.5"(190.5)	0.95"(24.3)	0.75"(19)	20"(508)	1.55"(40)	8
5"(125)	10.05"(255)	8.5"(215.9)	0.95"(24.3)	0.85"(22.2)	20.55"(522)	1.6"(41)	8
6"(150)	11"(280)	9.5"(241.3)	1"(25.9)	0.85"(22.2)	21"(534)	1.4"(36)	8
8"(200)	13.6"(345)	11.75"(298.5)	1.15"(29)	0.85"(22.2)	22"(559)	2.1"(53.5)	8
10"(250)	16"(406.4)	14.25"(362)	1.2"(30.6)	1"(25.4)	23.05"(585)	1.9"(48)	12
12"(300)	19.1"(485)	17"(431.8)	1.25"(32.2)	1"(25.4)	24"(610)	1.55"(39.5)	12

ANSI / ASME – CLASS 300

D (Size) in. (mm)	K (Pipe OD) in. (mm)	W Flange screw hole distance in. (mm)	C (Flange thickness) in.(mm)	Ø-M (Bolt hole diameter) in.(mm)	H Meter Height in.(mm)	L1 Pipe length in.(mm)	N Bolt qty
½"(15)	3.75"(95.2)	2.65"(66.7)	0.6"(14.7)	0.65"(15.9)	18.7"(475)	2.8"(71)	4
¾"(20)	4.65"(117.5)	3.25"(82.6)	0.65"(16.3)	0.75"(19)	18.7"(475)	2.25"(57.2)	4
1"(25)	4.9"(125)	3.5"(88.9)	0.7"(17.9)	0.75"(19)	18.7"(475)	2"(51)	4
1 ¼"(32)	5.3"(135)	3.85"(98.4)	0.75"(19.5)	0.75"(19)	18.7"(475)	2.3"(59)	4
1 ½"(40)	6.15"(156)	4.5"(114.3)	0.85"(21.1)	0.85"(22.2)	18.8"(477)	2.1"(53)	4
2"(50)	6.5"(165.1)	5"(127)	0.9"(22.7)	0.75"(19)	19"(482)	2.15"(54.7)	8
2 ½"(65)	7.5"(191)	5.85"(149.2)	1"(25.9)	1"(25.9)	19.3"(490)	1.7"(43)	8
3"(80)	8.25"(210)	6.65"(168.3)	1.15"(29)	1.15"(29)	19.55"(497)	1.45"(36.3)	8
4"(100)	10.05"(255)	7.85"(200)	1.25"(32.2)	1.25"(32.2)	20"(508)	1.1"(28.5)	8
5"(125)	11"(280)	9.25"(235)	1.4"(35.4)	1.4"(35.4)	20.55"(522)	1.1"(28.5)	8
6"(150)	12.6"(320)	10.65"(269.9)	1.45"(37)	1.45"(37)	21"(534)	0.65"(16)	12
8"(200)	15"(381)	13"(330.2)	1.65"(41.7)	1.65"(41.7)	22"(559)	1.4"(35.5)	12
10"(250)	17.5"(445)	15.25"(387.4)	1.9"(48.1)	1.9"(48.1)	23.05"(585)	1.15"(28.7)	16
12"(300)	20.5"(521)	17.75"(450.8)	2"(51.3)	2"(51.3)	24"(610)	0.85"(21.5)	16

2.5 Model Chart

Example	Tek-Vor 1300C	050S	W	R	M	1	B	Tek-Vor 1300C-050S-W-R-M-1-B
Series	Tek-Vor 1300C							Vortex Mass Flowmeter
Size		015S 025S 040S 050S 080S 100S 150S 200S 250S 300S 015M 025M 040M 050M 080M 100M 150M 200M 250M 300M						1/2", +/- 1.0% Accuracy, Standard Vortex Meter 1", +/- 1.0% Accuracy, Standard Vortex Meter 1-1/2", +/- 1.0% Accuracy, Standard Vortex Meter 2", +/- 1.0% Accuracy, Standard Vortex Meter 3", +/- 1.0% Accuracy, Standard Vortex Meter 4", +/- 1.0% Accuracy, Standard Vortex Meter 6", +/- 1.0% Accuracy, Standard Vortex Meter 8", +/- 1.0% Accuracy, Standard Vortex Meter 10", +/- 1.0% Accuracy, Standard Vortex Meter 12", +/- 1.0% Accuracy, Standard Vortex Meter 1/2", +/- 1.0% Accuracy, Multivariable Vortex Meter 1", +/- 1.0% Accuracy, Multivariable Vortex Meter 1-1/2", +/- 1.0% Accuracy, Multivariable Vortex Meter 2", +/- 1.0% Accuracy, Multivariable Vortex Meter 3", +/- 1.0% Accuracy, Multivariable Vortex Meter 4", +/- 1.0% Accuracy, Multivariable Vortex Meter 6", +/- 1.0% Accuracy, Multivariable Vortex Meter 8", +/- 1.0% Accuracy, Multivariable Vortex Meter 10", +/- 1.0% Accuracy, Multivariable Vortex Meter 12", +/- 1.0% Accuracy, Multivariable Vortex Meter
Process Connection			W F T					Wafer (Comes with two 150# ANSI flange adaptors) 150# ANSI Flange 300# ANSI Flange
Output				I H R				4-20mA, Pulse 4-20mA, Pulse, HART (only available for direct mount) 4-20mA, Pulse, Modbus RS485
Process Temperature					S M H			300 Degrees F (150 Degrees C) (MV or Standard Vortex) 480 Degrees F (250 Degrees C) (MV or Standard Vortex) 660 Degrees F (350 Degrees C) (Standard Vortex Only)
Electronics						1 2		Direct Mount Remote Mount (comes with 15 ft. of cable)
Diagnostics							B	Bluetooth

3 Installation

This section covers instructions on installation and commissioning. Installation of the device must be carried out by trained; qualified specialists authorized to perform such works.



CAUTION

- When removing the instrument from hazardous processes, avoid direct contact with the fluid and the meter
 - All installation must comply with local installation requirements and local electrical code
-

3.1 General Notes on Installation

- **Ambient Temperature**

Please avoid installing the flowmeter at a location where temperature could dramatically change. If the meter is under heavy heat radiation, please implement effective heat insulation and venting method.

- **Atmosphere**

Please do not install the flowmeter at a location where the atmosphere contains a high level of corrosive substance. If the meter cannot be installed at a better location, please make sure there is enough venting.

- **Vibration**

The flowmeter should not be installed at a location where it could have strong vibration. If the mounting pipeline could have heavy vibration, the pipeline should be held steady by some support racks.



CAUTION

- All screws and bolts should be tightened
 - Make sure there is no leakage point on the connection
 - The process pressure should not be higher than the flowmeter's rated pressure
 - Once the meter is under pressure, please do not screw the bolts and screws
-

3.2 Safety Precautions

For person and equipment safety, please observe below provision:

- Before installation, please read this manual properly, check the safety requirements for flowmeter, relevant equipment, and environment.

- Install and maintain flowmeter by person who has the knowledge of flowmeter.
- Install flowmeter sensor and its pipe correctly, make sure the seal and safety, liquid pressure shall be no more than the maximum working pressure on nameplate.
- Prevent electric shock accident.
- Lifting equipment for flowmeter should confirm to safety provision.

3.3 Installation Condition



NOTE

When the upstream pipeline is a T-type and the flowmeter and the valve downstream of the meter is shut, fluid will flow toward pipe B, however the meter may still show a reading, as it may be detecting a pulsating pressure. In this case, please close the upstream valve V1.

- Standard Installation

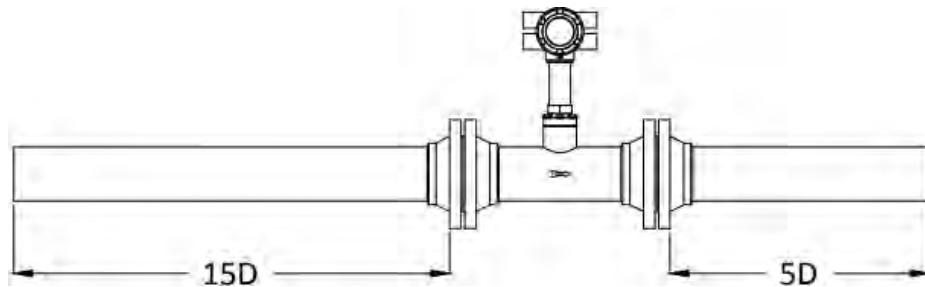

- Installation for the Pipe Reducer

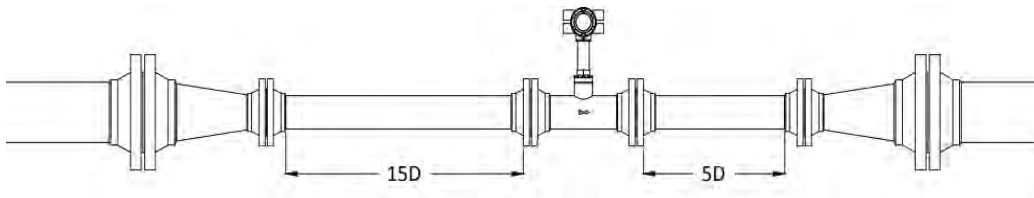

- Installation for the Pipe Expander

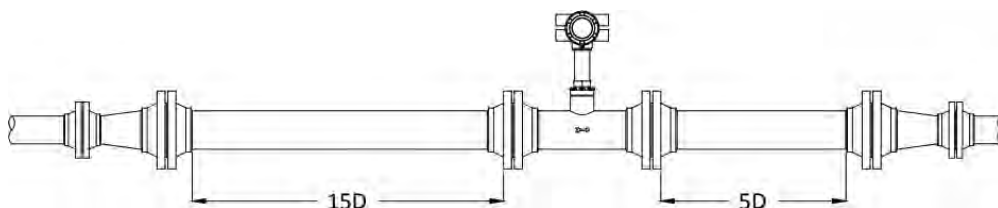

- Installation for Single Bend Pipeline

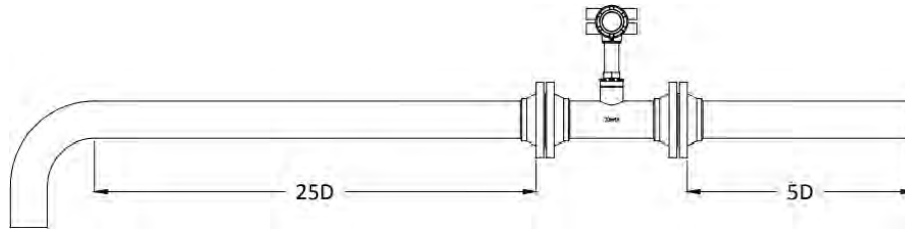

- Installation for Double Bend Pipeline

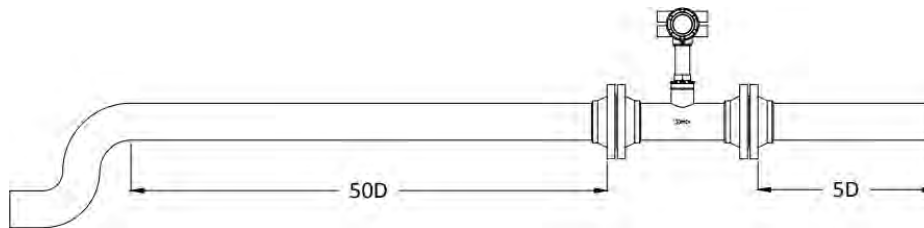

- Installation when Valve is at Downstream

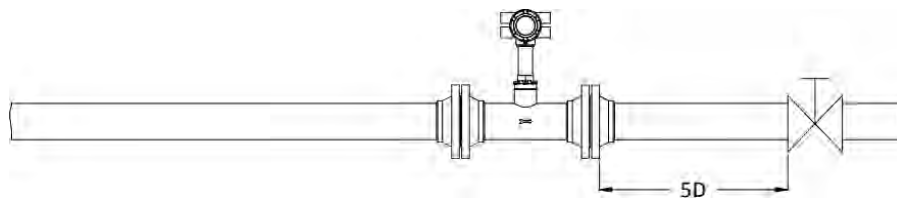

- Installation when Valve is at Upstream

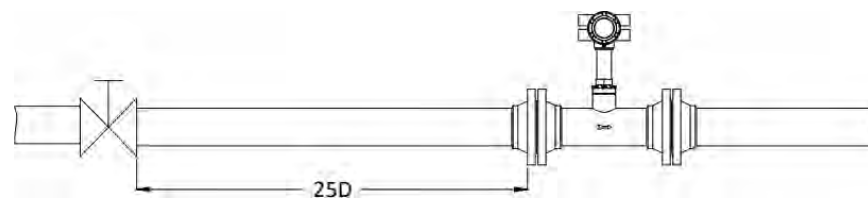

- Installation when Temperature and Pressure Sensors are at Downstream

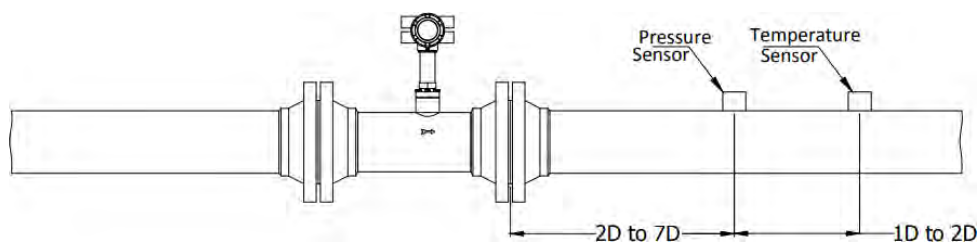

- Installation when Roots Blower, Piston Blower, or Compressor are at Upstream

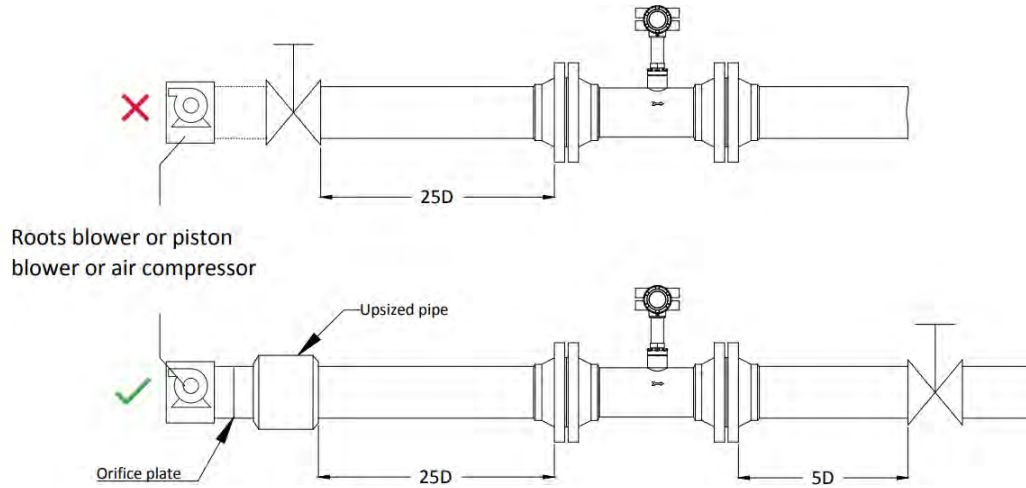

- Installation of a Flowmeter after a Piston Pump

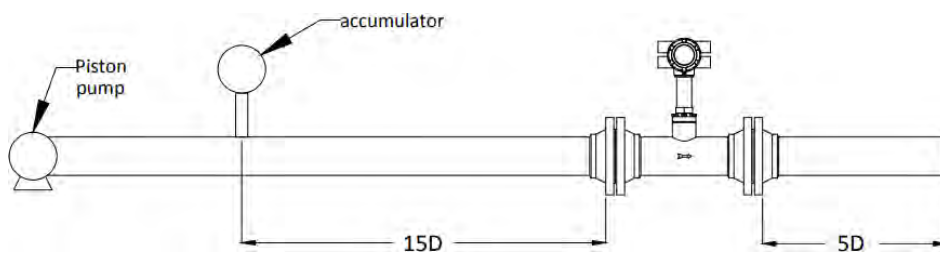

- Installation when T-type Pipeline is at Upstream

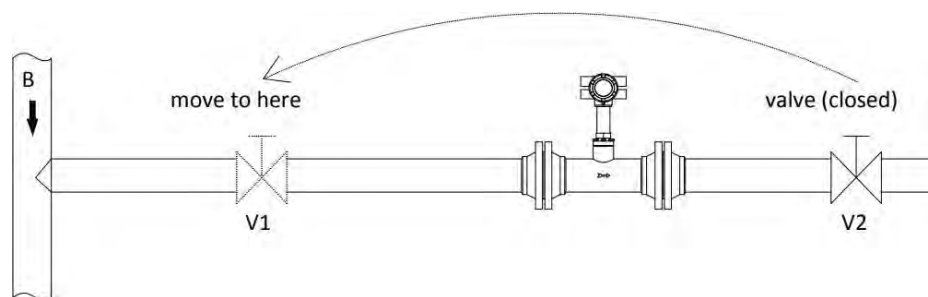

4 Electrical Installation

This section covers all electrical connection requirement. Electrical connection of the device must be carried out by trained; qualified specialists authorized to perform such work by the installation site.



WARNING

- Connect all electrical cables when the power is switched off. If the device does not have switch-off elements, then, overcurrent protection devices, lightning protection and/or energy isolating devices must be provided by the customer.
 - The device must be grounded to a spot in accordance with regulations in order to protect personnel against electric shocks.
-



NOTE

- When using the measuring device in hazardous areas, installation must comply with the corresponding national standards and regulations and the Safety Instructions or Installation or Control Drawings.
-

4.1 Terminal Board

The Tek-Vor 1300C has two different terminal boards; a 5-terminal board for standard models and a 12-terminal board for multi-variable models.

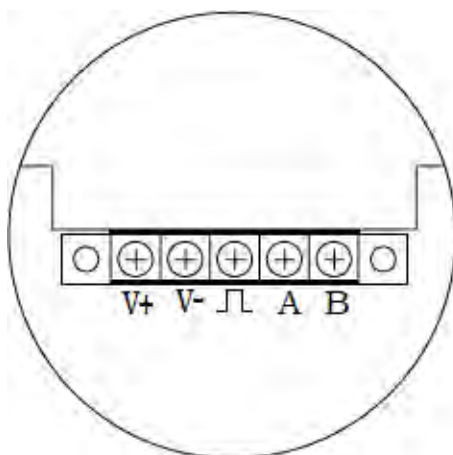

5-terminal Board

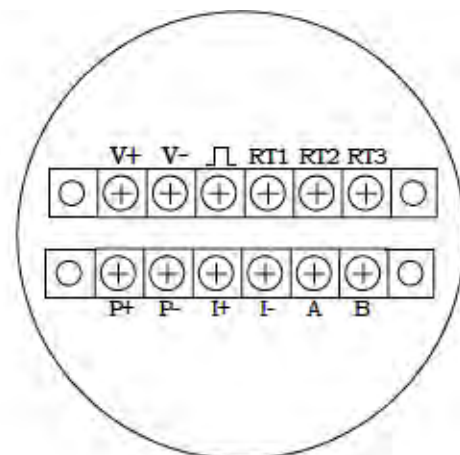

12-terminal Board

Power supply	V +
	V -
Pulse output	
RS485 communication	A+
	B-
Current	I+
	I-
Temperature sensor	RTD1, RTD2, RTD3
Pressure Sensor	P+
	P-

On the above boards, V+ and V- are for power.  is the pulse output terminal. A, B are “+” and “-” terminals for RS485 Modbus communication. I+ and I- are “+” and “-” for 3-wire or 4-wire 4to 20 mA. RT1, RT2, RT3 are for separate RTD. P+, P- are for pressure transmitters. The Tek- Vor 1300C multi-variable version has a built in RTD and pressure sensor, so there is no requirement to wire for temperature or pressure compensation.

4.2 Wiring for a 5-Terminal Board

4.2.1 Wiring for a 3-Wire Pulse Output

A 3-wire pulse output requires a power source of 13.5 to 42VDC. VFM uses a current pulse output with 50% duty ratio. If the pulse-receiving instrument requires a voltage pulse, add a resistor between “” and “V-”; the resistance should be within 500 ohms to 1000 ohms, and the power consumption should be no less than 0.5W.

***Note:- Pulse Output:** Active (Pulse, V-), **4-20 mA output:** Passive (I+, I-),

Remarks for Pulse Output: With/Without 250 ohms resistor across Pulse &V- terminals,

Remarks for 4-20 mA output: External 24VDC to I+.connect PLC/Multimeter between I- and -Ve of power supply, **Diagrams for Pulse:** Active, **Diagrams for 4-20mA:**

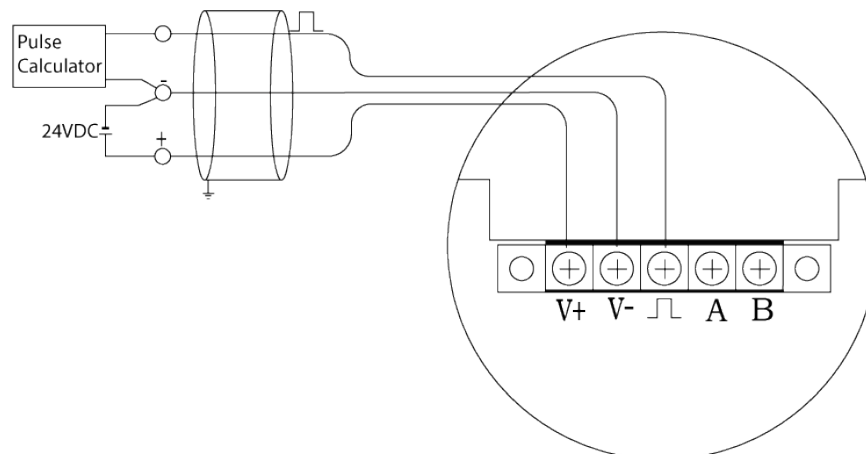

4.2.2 Wiring for a 2-Wire HART with 4 to 20mA

When there is no temperature and pressure compensation and the power source is 24VDC, the maximum load for 4 to 20mA analog is 500 ohms. When there is temperature and pressure compensation and the power source is 24VDC, the maximum load for 4 to 20mA analog is 400 ohms. When using a HART communicator, add a 250 ohms load resistor.

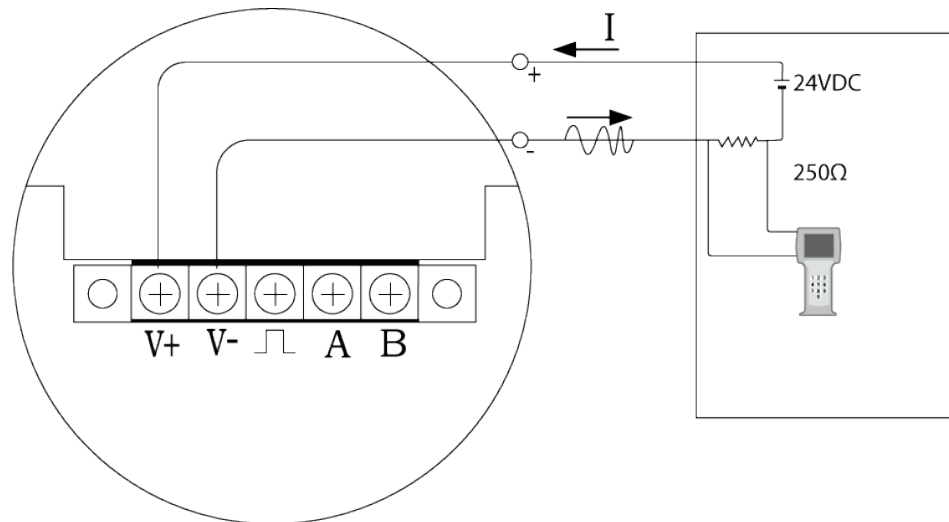

4.2.3 Wiring for RS485

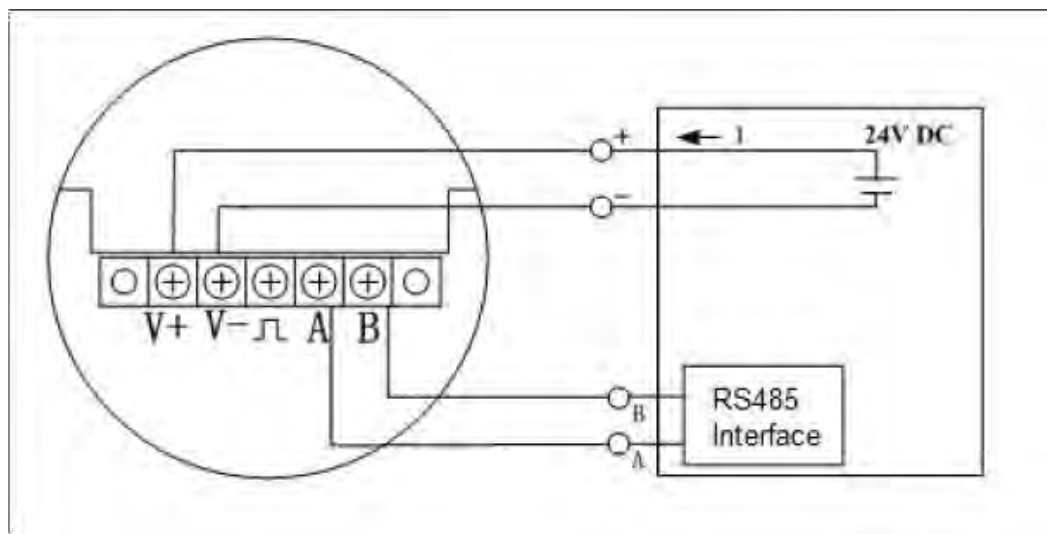

4.3 Wiring for a 12-Terminal Board

4.3.1 Wiring for a 3-Wire Pulse Output

A 3-wire pulse output requires a power source of 13.5 to 42VDC. VFM uses a current pulse output with 50% duty ratio. If the pulse receiving instrument requires a voltage pulse, add a

resistor between “” and “V-”; the resistance should be within 500Ω to 1000Ω, and the power consumption should be no less than 0.5W.

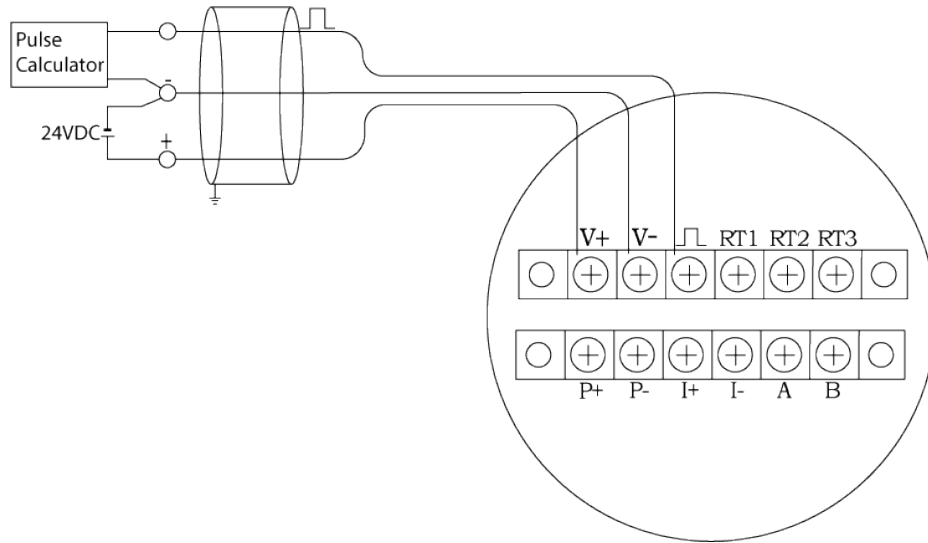

4.3.2 Wiring for a 3-Wire HART with 4 to 20mA

When the power source is 24VDC, the maximum load for 4 to 20mA analogue is 500 ohms.

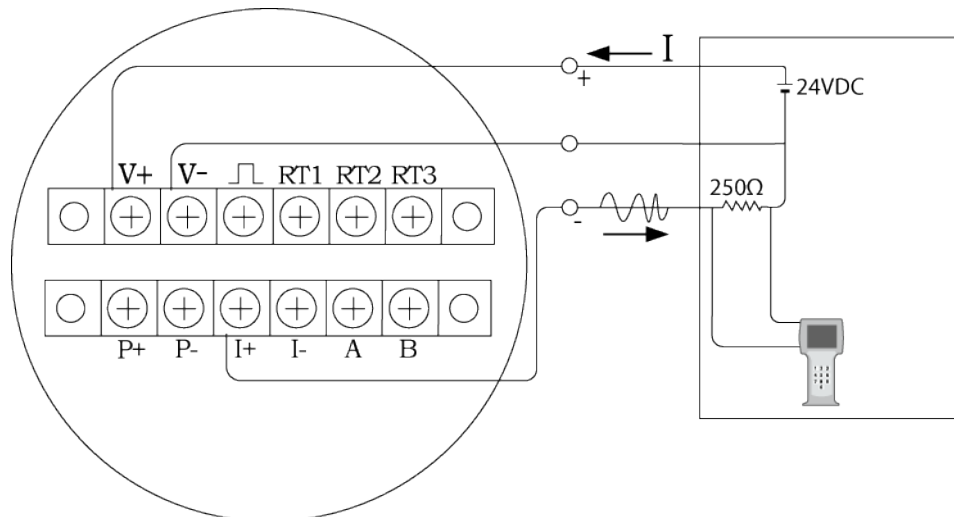

4.3.3 Wiring for a 4-Wire HART with 4 to 20mA

When the power source is 24VDC, the maximum load for 4 to 20mA analogue is 500 ohms.

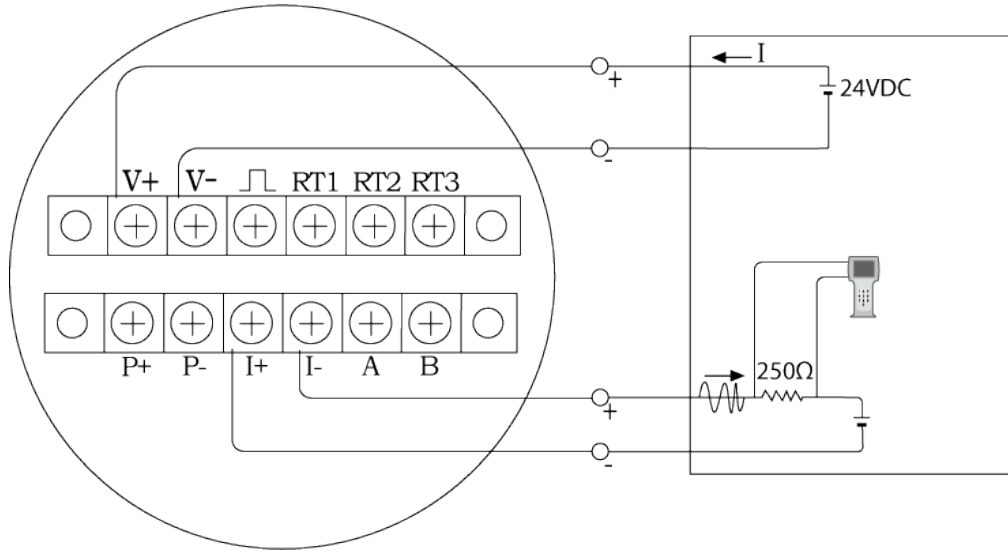

4.3.4 Wiring for RS485

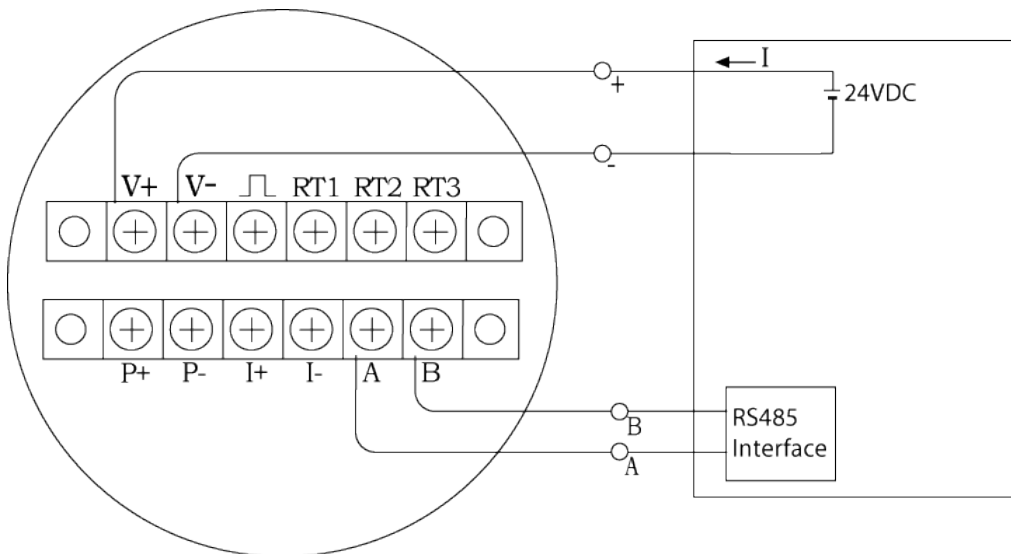

5 Operation

This section covers operation techniques and guidelines.

5.1 Display

The Tek-Vor 1300C Vortex Flowmeter provides local settings and a display panel. It can display several variables on this multifunctional LCD display. It has 3 buttons.

5.1.1 Introduction to the Multi-Functional LCD Display

The Tek-Vor 1300C Vortex Flowmeter has a display to indicate “Frequency”, “Flow Rate”, and “Total flow”. The Tek-Vor 1300C Multi-variable version or a standard Tek-Vor 1300C working with RTD and pressure transmitters can also indicate other variables such as temperature/pressure/density/mass flow”.



The LCD display has 2 areas to display the content - the upper row and the lower row. The upper row displays the flow rate/mass flow/standard flow rate. Immediately below the upper row is displayed the unit of the variables in the upper row.

The lower row display indicates other variables, such as frequency/ pressure/ temperature/ density/ total flow/ velocity. Immediately below the lower row is displayed the unit of the variables in lower row.



The Tek-Vor 1300C Multi-variable version and the Standard version with temperature and pressure compensation, can calculate and display the mass flow of both saturated steam and superheated steam.

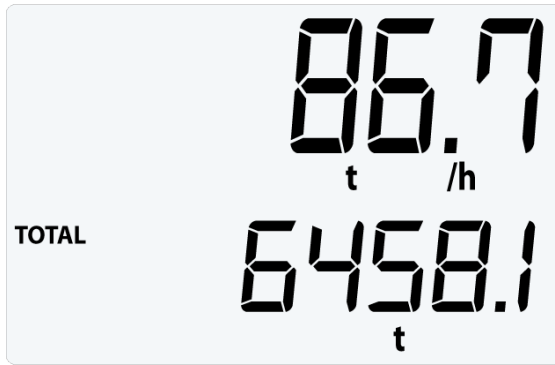

The Tek-Vor 1300C multi-variable version and the standard version with temperature and pressure compensation can display variables such as temperature/ pressure/ density. Use the “Switch” button to switch to the next variable and it will display for 30 seconds.



Below is a sample of the temperature being displayed. The lower row can also consistently display a variable through the settings. The default variable displayed on the lower row is total flow. You can also set the lower row to display several variables in circular turn.



5.1.2 Units of the Variable Displayed

Subject	Variable	Unit	Circular Display Code
TOTAL	Total Flow	m/s (ft/sec)	01
TEMP	Temperature	°F(°C)	02
PRES	Pressure	MPa or kPa	03
FREQ	Frequency	Hz	04
DENS	Density	kg/m ³	05

5.1.3 Three Button Setting

Tek-Vor 1300C vortex flowmeter has three buttons on the top of the display, which are  used as L-R button,  used as U-D button,  used as Enter button.

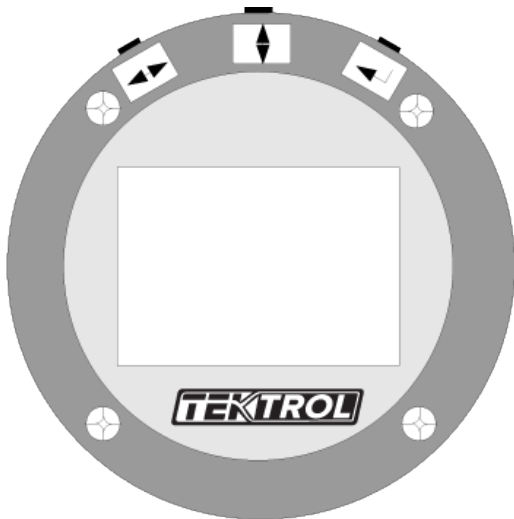

The “U-D” button is used to switch the displaying content up and down, the “L-R” button can be used for the left and right digits of total flow. The “Enter” button displays the entire digits of total flow directly.

5.1.4 Total Flow Display

The Tek-Vor 1300C can display 9 digits to the left of decimal point and 3 digits to the right of it. When there is more than 6 digits, the total flow reading will be displayed twice; first it will display digits on right, and then second the digits on left. You can use the “L-R” button to switch between the right and left digits. The left digits will be displayed with “x1000”

To check the right digits now, press the “L-R button”, the display will be



According to the above images, the total flow is 569864.581 kg.

5.1.5 Modes

The Tek-Vor 1300C Vortex Flowmeter have three different Modes:

- Working Mode
- Setting Mode
- Calibration Mode

When under the Setting mode you can set the flowmeter while the flowmeter is still processing, so setting will not have effect on the measuring parameters. The calibration of the flowmeter has been finished in manufacturer’s laboratory before delivery, including temperature and pressure calibration along with the setting of the high-limit and the low-limit of 4 to 20mA stimulation output.

5.2 Parameter Setting

The Tek-Vor 1300C Vortex Flowmeter has Digit and Code Setting functions. Use the Code Setting function to set parameters such as fluid type, compensation type, and output signal. Use the Digit Setting function to set parameters related to a number such as pipe size, flow range factor.



NOTE

Tek-Vor 1300C Vortex Flowmeters have been set according to requirement before delivery. Please do not change the setting unless it is necessary and under correct instruction

5.2.1 Code Setting

To enter the Code Setting in working status, press the “Enter” button, and the “U-D” button at the same time.

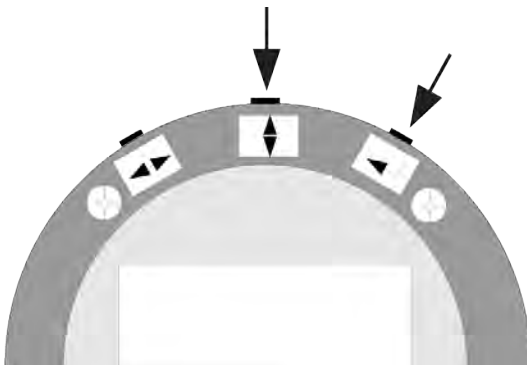

When in the code setting function, the upper row will display the reference number for the code setting, and the lower row will display the contents of this parameter. The digit that is flashing is the digit under the setting. In the diagram below, this is shown as C01=02, which means the fluid type is liquid.



When in the code setting function, the user can now use “L-R” to select which digits on the display are to be set, and “R-D” to switch the digit to between 0 and 9. When “Enter” is pressed, it will set the lower row. Press “Enter” again to check if the setting is available. If the

setting is available, the setting made will be cancelled and the display will not flash. If this happens, press “L-R” or “U-D” to set it again. When the display is not flashing, press “Enter” to save and go to the next setting. If the user wants to quit the code setting function, hold down “Enter” and press “U-D” at the same time.

5.2.2 Digit Setting

To enter the Digit Setting function in working status, hold down “Enter” and press “L-R” at the same time.

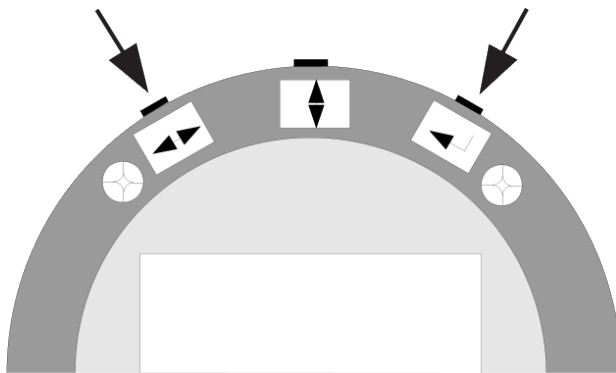

When in the Digit Setting function, the upper row will display the reference number of the digital setting and the lower row will display the contents of this parameter. In the diagram below, the digit that is flashing is the digit under the setting. This means D001=1.60000; the maximum pressure is 1.6 (unit according to other settings).



When in the Digit Setting function, the user can use “L-R” to select which digit on the display panel are to be set and use “R-D” to switch the digit to between 0 and 9. The first press of “Enter” sets the lower row. Press “Enter” again to check if the setting is available. If the setting is available, the setting made will be cancelled and the display will not flash. If this happens, press “L-R” or “U-D” to set it again. When the display is not flashing, press “Enter” to save and go to the next setting.

If want to quit the digital setting function, again hold down “Enter” and press “U-D” at the same time.

5.2.3 Setting Address

- **Code Setting Address**



NOTE

If the unit of flow rate is changed or the measurement is changed from the flow rate to mass flow, users can reset the total flow to 0 or record the current total flow:

Total flow= (number of times over total flow) * (maximum display of total flow) + (Current total flow reading)

Code Setting Address	Item	Code	Description of Code
01	Fluid	01	Gas
		02	Liquid
02	Density Compensation	00	Volume Flow Display, No Density Compensation
		01	Density Preset
		02	Pressure Compensation (for Saturated Steam Pressure Not Larger than 20MPa)
		03	Temperature Compensation (for Saturated Steam)
		04	Temperature and Pressure Compensation (for Superheated Steam)
		05	$\rho=A+BP$ (Pressure Compensation)
		06	$\rho=A+BT$ (Temperature Compensation)
		07	AGA-NX-19 to Calculate Compressibility Factor
		08	Temperature and Pressure Compensation to get for Normal Condition Flow Rate of Gas
		09	AGA-8 to Calculate Compressibility Factor
05	Output	01	Pulse
		02	4 to 20mA or HART at 4 to 20mA
		03	200-1000HZ Frequency Output, Set Output in C06

		04	Frequency Output for Total Flow, Set Factor in D013
06	200-1000Hz Output Parameter	00	Flow Rate
		01	Temperature
		02	Pressure
07	Damping	01 to 99	1 to 99 Seconds
08	Instrument Number	00 to 99	For Modbus
		00 to 15	For HART Communication
09	Baud Rate	01	1200 No Parity 1 Stop Bit
		02	1200 Even Parity 1 Stop Bit
		03	2400 No Parity 1 Stop Bit
		04	2400 Even Parity 1 Stop Bit
		05	4800 No Parity 1 Stop Bit
		06	4800 Even Parity 1 Stop Bit
		07	9600 No Parity 1 Stop Bit
		08	9600 Even Parity 1 Stop Bit
		09	19200 No Parity 1 Stop Bit
		10	19200 Even Parity 1 Stop Bit
		11	1200 Odd Parity 1 Stop Bit
		12	2400 Odd Parity 1 Stop Bit
		13	4800 Odd Parity 1 Stop Bit
		14	9600 Odd Parity 1 Stop Bit
		15	19200 Odd Parity 1 Stop Bit
		16	38400 No Parity 1 Stop Bit
		17	38400 Even Parity 1 Stop Bit
		18	38400 Odd Parity 1 Stop Bit
		19	57600 No Parity 1 Stop Bit
		20	57600 Even Parity 1 Stop Bit
		21	57600 Odd Parity 1 Stop Bit
		22	115200 No Parity 1 Stop Bit
		23	115200 Even Parity 1 Stop Bit
		24	115200 Odd Parity 1 Stop Bit
10	Time Unit for Flow Rate	00	/s
		01	/min
		02	/h
11	Mass Unit	01	Kg
		02	Ton
		03	Lb
12	Volume Unit for Flow Rate	01	m ³
		02	L
		03	ft ³
		04	US gal
		05	UK gal
13	Pressure Unit	01	MPa

		02	kPa
		03	Psi
		04	Bar
14	Temperature Unit	01	°C
		02	°F
		03	K
15	Right Digits Number for Total Flow	00 to 05	00 : No Right Digits for Total Flow 01 to 05 : 1 to 5 Right Digits for Total Flow
16	1st Row Display Parameter	01	Flow Rate
		02	Percentage of Flow Rate to Flow Range
17	Lower Row Display Parameter	00	No Display
		01	Total Flow
		02	Temperature
		03	Pressure
		04	Density
		05	Frequency
18	Density Unit	01	Kg/m ³
		02	lb/ft ³
30	Time Space for Circle Display	00 to 30	1 to 30 : 1 to 30 Seconds Between the Display of Different Parameter
38	Sequence of Float (under RS485 Communication)	01	LL_LH_HL_HH
		02	HH_HL_LH_LL
		03	LH_LL_HH_HL
		04	HL_HH_LL_LH
47	Password Function	0	Off
		1	On
48	Set Password	0	Keep the Password
		1	Change the Password
49	Spectrum Analyzing Checking	0	Working Status
		12	Spectrum Analyzing Checking
50	Total Flow Reset	0	Reset Total Flow to 0
		1	Default
55	Times of Over Total Flow	00 to 99	For Reading Only
60	Restore to Backup Date	6	Restore to Backup Date
61	Save Setting Backup	16	Save Current Setting for Backup

- Digit Setting Address

Digit Setting Address	Item	Code	Description of Code
001	Max Pressure	[-99999, 999999]	Max Input/Output Pressure
002	Min Pressure	[-99999, 999999]	Min Input/Output Pressure
003	Max Temperature	[-99999, 999999]	Max Input/Output Temperature
004	Min Temperature	[-99999, 999999]	Min Input/Output Temperature
005	Pre-set Density	[0, 999999]	When C02=01, the Flowmeter will use this Density, Unit According to Setting
008	K Factor	[0, 999999]	K Factor According to Calibration Result, unit is Pulses/Litre. Flow=3.6xFreq/K
009	Max Flow Rate	[0, 999999]	Unit is same as Flow Rate, Max/Min Flow Rate of 4 to 20mA and 200 to 1000Hz Output
010	Min Flow Rate	[0, 999999]	
013	Pulse Factor for Total Flow	[0, 999999]	Used when Freq. Output of Total Flow
014	Ambient Pressure	[0, 999999]	Unit According to Setting
015	Pipe Size	[0, 999999]	Unit is mm
021	Cut off Small signal	[0, 999999]	Unit is Hz
030	Specific Density of Compressibility Factor	[0.55, 0.90]	For Calculation of Compressibility Factor of Natural Gas
031	Mol % of N ₂ and H ₂	[0, 0.1]	For Calculation of Compressibility Factor of Natural Gas
032	Mol % of CO ₂	[0, 0.3]	For Calculation of Compressibility factor of Natural Gas
033	Higher Heating Value	[20, 48]	KJ/Mol, for Calculation of Compressibility Factor of Natural Gas



NOTE

Maximum frequency output=10KHz. The pulse factor for total flow should be set properly according to the current total flow

5.2.4 Example of Setting

For Tek-Vor 1300C Vortex Flowmeter, measure gas in a 2" (DN50) pipe;
K factor= 7.802P/L, density pre-set, mass flow display unit is kg/h. 4 to 20mA output with a flow range of 0 to 4000kg/hr.

Code Setting	Address	Code	Description
	01	01	Gas
	02	01	Density Pre-set
	05	02	4 to 20mA Analog Output
Digit Setting	005	2.0000	Density=2
	008	7. 802	K Factor=7.802 P/L
	009	4000	Flow Rate of 20mA
	010	0	Flow Rate of 4mA
	015	50	Pipe Size=50mm

5.2.5 Password Setting Instruction

Select the code setting, set C47=01, confirm and then enter the password setting interface:

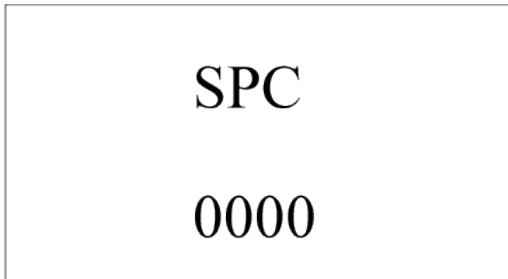

To set a new password, enter the correct password twice; the password will only become active if both entries are correct; otherwise users have to enter the password again. If the power is cut off during a password setting process, the password will revert to 2000 as default. When a password becomes active, users will have to enter the correct password before the flowmeter can be set. If the user enters 3 times consecutively, the display will revert to the normal display.

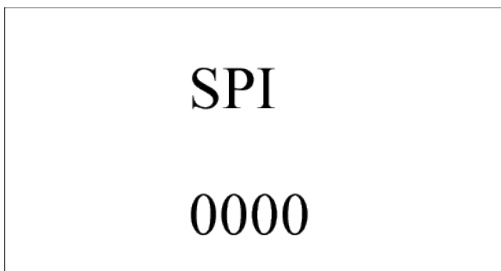

5.3 Communication using RS485 MODBUS

- **Interface Regulation**

1. The communication interface should be RS485, the range of Baud rate should be 1200 to 115200
2. The wiring terminal for communication is “A” and “B”. Refer to the Electrical Installation Section for Wiring Terminal information
3. The communication should comply with MODBUS-RTU statute

The combination of a communication signal: Address code - function code – data segment – CRC calibration code. The distance between two characters should not be longer than one character, or it will be considered the beginning of a new message or the end of an old message. The message is combined with hexadecimal arrays.

a. Address of the Displayed Date

Register Address	Usage	Nature	Date Type
0-1	Flow Rate	Read Only	Float
2-3	Frequency	Read Only	Float
4-5	Reserved	Read Only	Float
6-7	Pressure	Read Only	Float
8-9	Temperature	Read Only	Float
10-11	Density	Read Only	Float
12-13	Reserved	Read Only	Float
14-15	Reserved	Read Only	Float
16-17	Reserved	Read Only	Float
18-19	Reserved	Read Only	Float
20-21	Reserved	Read Only	Float
22-23	Reserved	Read Only	Float
24-25	Total Flow	Read Only	Float

The displayable date including flow rate, frequency, pressure, temperature, density and total flow, if the meter does not have density compensation, then the reading of pressure and temperature will both be 0. Using function code 03 according to the address above and shifting can read the date of the parameters in above chart.

b. Addresses of Code Setting

Resister	Usage	Range	Nature	Date Type
1000	Fluid Type C01	1-2	Read Only	Short
1001	Density Compensation C02	0-9	Read/Write	Short
1004	Output C05	1-4	Read/Write	Short
1005	200-1000Hz Output Parameter C06	1-3	Read/Write	Short
1006	Damping C07	1-99	Read/Write	Short
1007	Instrument Number C08	Hart (0 to 15) MB (1 to 99)	Read	Short
1008	Baud Rate C09	1-24	Read	Short
1009	Unit of Time C10	0-2	Read/Write	Short
1010	Mass Unit C11	1-3	Read/Write	Short
1011	Volume Unit C12	1-5	Read/Write	Short
1012	Pressure Unit C13	1-4	Read/Write	Short
1013	Temperature Unit C14	1-3	Read/Write	Short
1014	Right Digits Number for Total Flow C15	0-5	Read/Write	Short
1015	1st Row Display Parameter C16	1-2	Read/Write	Short
1016	Lower Row Display Parameter C17	0-5	Read/Write	Short
1017	Density Unit C18	1-2	Read/Write	Short
1029	Time Space for Circle Display C30	0-30	Read/Write	Short
1030	First Parameter Displayed in Circle Display C31	0-5	Read/Write	Short
1031	Second Parameter Displayed in Circle Display C32	0-5	Read/Write	Short

1032	Third Parameter Displayed in Circle Display C33	0-5	Read/Write	Short
1033	Fourth Parameter Displayed in Circle Display C34	0-5	Read/Write	Short
1034	Fifth Parameter Displayed in Circle Display C35	0-5	Read/Write	Short
1035	C36	0-1	Read/Write	Short
1036	C37	0-10	Read/Write	Short
1037	Sequence of Float C38	1-4	Read/Write	Short
1046	Password Function C47	0-1	Read	Short
1047	Set Password C48	0-1	Read	Short
1048	Spectrum Analyzing Checking C49	0-12	Read/Write	Short
1049	Total Flow Reset to 0 C50	0-1	Read/Write	Short
1050	C51	0-0	Read/Write	Short
1051	C52	0-99	Read/Write	Short
1052	C53	0-0	Read/Write	Short
1053	C54	0-0	Read/Write	Short
1054	Times of Over Total Flow C55	0-0		Short
1059	Restore to Backup Date C60	0-99	Read/Write	Short
1060	Save Setting Backup C61	0-99	Read/Write	Short

Use the function codes 04 and 06 to access the address for code setting above.

c. Addresses of Digit Setting

Resister	Usage	Restriction of modification	Nature	Date type
2000 to 2001	D001 Max Pressure	-1e5 to 1e6	Read/Write	Float
2002 to 2003	D002 Min Pressure	-1e5 to 1e6	Read/Write	Float
2004 to 2005	D003 Max Temperature	-1e5 to 1e6	Read/Write	Float
2006 to 2007	D004 Min Pressure	-1e5 to 1e6	Read/Write	Float
2008 to 2009	D005 Density	0 to 1e6	Read/Write	Float
2014 to 2015	D008 K Factor	0 to 1e6	Read/Write	Float
2016 to 2017	D009 Max Flow rate	0 to 1e6	Read/Write	Float
2018 to 2019	D010 Min Flow rate	0 to 1e6	Read/Write	Float
2024 to 2025	D013 Factor for Total Flow Output	0 to 1e6	Read/Write	Float
2026 to 2027	D014 Ambient Pressure	0 to 1e6	Read/Write	Float
2028 to 2029	D015 Pipe Size	0 to 1e6	Read/Write	Float
2040 to 2041	D021 Cut off Small Signal	0 to 1e6	Read/Write	Float
2058 to 2059	D030 Specific Density	[0.55, 0.90]	Read/Write	Float
2060 to 2061	D031 mol% of N ₂ and H ₂	[0, 0.1]	Read/Write	Float
2062 to 2063	D032 mol% of CO ₂	[0, 0.3]	Read/Write	Float
2064 to 2065	D033 Higher Heating Value	[20, 48]	Read/Write	Float

The chart above indicates the register address, usage of the register, restriction of modification, read/write nature, and date type. The registers above are all holding registers; the supporting function codes are 03,04,06, and 16.

- **Command**

Function codes 03 and 04 are the codes supported for reading the registers. Function code 06 is for writing one register. Function code 16 is for writing multiple registers. Function code 06 is only supported for writing a short date. Function code 16 is supported for writing both a short date and a float date.

a. Function Code 03 – Read Register

Request	Response
01: Address	01: Address
03: Function Code	03: Function Code
00: Register Address Higher	04: Quantity of Bit
00: Register Address Lower (display the address)	80: Date 1
00: Register Number Higher	04: Date 2
02: Register number lower	80: Date 3
CRCL: CRC Parity code lower	80: Date 4
CRCH: CRC parity code higher	CRCL: CRC Parity code lower
	CRCH: CRC parity code higher



NOTE

To read a float date, both the quantity of the register address and its value have to be even, or response will be “error:

Function code 04 – Same as function code 03

b. Function Code 06 – Write One Register

Request	Response
01: Address	01: Address
06: Function code	06: Function code
00: Register address higher	00: Register address higher
01: Register address lower (code setting address)	01: Register address lower
00: Value higher	00: Value higher
04: Value lower	04: Value lower
CRCH: CRC parity code higher	CRCH: CRC parity code higher
CRCL: CRC Parity code lower	CRCL: CRC Parity code lower

c. Function Code 16 – Write Multiple Registers

Request	Response
01: Address	01: Address
10H: Function code	10H: Function code
00: Register address higher	00: Register address higher
01: Register address lower (digital setting address)	01: Register address lower
00: Quantity of register higher	00: Quantity of register higher
02: Quantity of register lower	02: Quantity of register lower
04: Quantity of values	CRCH: CRC parity code higher
86H: Value 1	CRCL: CRC Parity code lower
00: Value 2	
00: Value 3	
48H: Value 4	
CRCH: CRC parity code higher	
CRCL: CRC Parity code lower	



Function code 16 is supported to write both a short date and a float date. However, for a float date, the first register address and the quantity of the registers must both be even, or writing will not be allowed

- **Calculation of CRC Parity Code**

Request	Response
01: Address	N1 CRC=OFFFH is Initial Value
10: Function code	N2 XOR Operation the CRCL and N1
00: Register Address Higher	N3 CRC Move 1 Bit Right, if Move Out is 1 Bit
01: Register Address Lower	N4 CRC=CRC XOR A001H
00: Register Quantity Higher	N5 if Move Out is 0, CRC=CRC
04: Register Quantity Lower	N6 Move Right for 8 Times to Finish the N1 Calculation
04: Date Quantity	N7 ...
80: Date 1	N8 XOR Operation the CRCL and N11
04: Date 2	N9 CRC move 1 bit Right, if Move Out is 1 Bit
80: Date 3	N10 CRC=CRC XOR A001H
80: Date 4	N11 if Move Out is 0, CRC=CRC
CRCL: CRC Parity Code Lower	Move Right for 8 Times to Finish the N11 Calculation
CRCH: CRC Parity Code Higher	Get the CRC Calibration Value

5.4 Bluetooth Access

5.4.1 How to download the application

- Visit Apple's application store
- Search "Tek-trol Bluetooth" or "Tek-Bluetooth" to find our app profile
- Download the application



5.4.2 Access the application

- Open application
- Enter login information (ID: 20000000007, Verify code:341234)
- This will take you to "device list" where your phone will automatically sync with your product (you must be close enough)

5.4.3 Utilize the application

Follow prompts and menu to navigate through the many features of our Bluetooth application!



6 Maintenance

This section covers maintenance techniques and guidelines.

6.1 How to Rotate Transmitter Head

- Before rotating the transmitter, please take out the tightening screw under the transmitter
- Rotate transmitter head up to 180° and tighten the screw

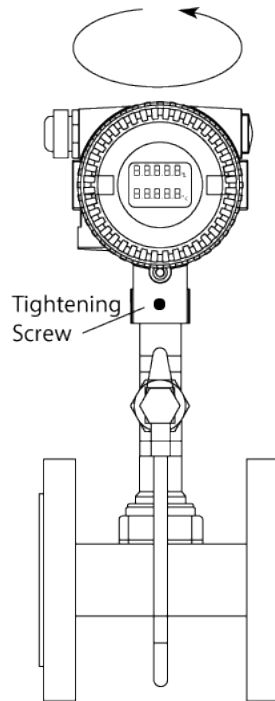

6.2 Replace a Transmitter Circuit Board

- Make sure the power is off before replacing the transmitter
- Remove the front cover
- Loosen the 4 screws on the circuit board
- Remove all the plugs on the circuit board, then remove the circuit board
- Put the new circuit board in and put the plug on
- Tighten the 4 screws on the board, fix the front cover back on

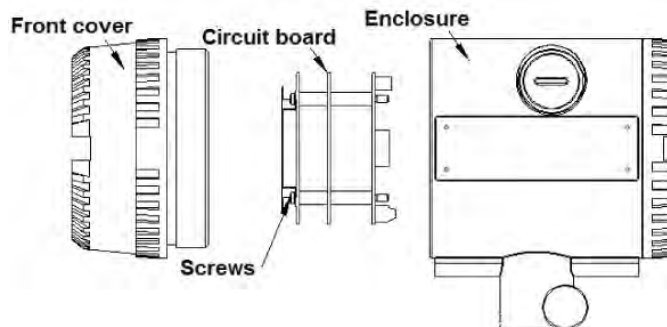

6.3 Replace the Pressure Sensor

- Make sure the pressure valve on the meter is off before replacing the pressure transmitter
- Loosen the nut that is holding the pressure sensor
- Remove the front cover, loosen the circuit board and remove the wiring of the pressure sensor
- Remove the enclosure
- Loosen the gasket and sealing nut
- Slowly take out the pressure sensor and the wire
- After installing the pressure sensor, follow the reverse process of instruction

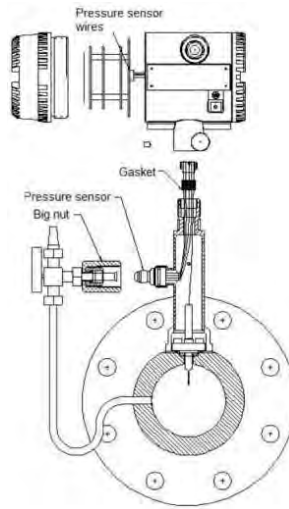

7 Troubleshooting

This section provides troubleshooting techniques for most common operating problems.

7.1 Troubleshooting Table

Error	Reason	Troubleshooting	Repair
No Display	Power Supply Failure	Test the voltage on the power source with a universal meter	Re-wire the power or use a new power
	Power is Not Wired	Test the voltage on the power source with a universal meter	Wire the power
	Cable if Broken	Check for a break off point on the cable	Check the cable and re-wire
	Wrong Wiring	Check if wired to the correct terminal	Re-wire
Displayed Flow Rate is 0 While there is Flow in the Pipe	Flow Rate is Lower than the Meter's Lower Limit	Increase the flow rate to check	Increase the flow rate or replace with a new proper flowmeter
	The Flow Rate of Small Signal Cut-off Function is too High	Check the small signal cut off setting	Set the small signal cut off to a proper value

	Energy Threshold Value is too High	Check if the Energy threshold value is too high in spectrum analyzing checking mode	Set the Energy threshold value to a proper value
	Transmitter Function Failure	Replace the transmitter with another transmitter of same type to check	Replace the transmitter
	Sensor is Damaged	Increase the flow rate to check first, then install the transmitter to another flowmeter in same type to check.	Replace the sensor
	Pipeline Blocked, or Sensor Jammed.	If all above possibilities are eliminated, please check the pipe line and installation.	Re-install the flowmeter
The Flowmeter has Flow Reading with No Flow in the Pipe	Power Frequency Interference	Check the frequency display on meter is stable at the value that same as the power frequency	Re-wire the meter with shielded cable according to requirement.
The Flow Rate Reading Fluctuates Significantly	High Voltage Instrument or High Frequency Interference close to the Flowmeter	Check if there is high voltage instrument or high frequency interference close to the flowmeter	Re-locate the flowmeter
	Heavy Vibration on the Pipeline	Locate the vibration on the pipeline by touching it with hand	Re-locate the flowmeter
	Valve not Closed Properly - Flow Leaks into the Pipe	Check pressure and check if valve is closed and sealed	Repair the valve
	The Gasket and the Pipe are not Concentric	Check the position of the gasket	Re-install the gasket
	The Flowmeter Pipe Body and the Pipeline are not Concentric	Check if the flowmeter pipe body and the pipe line are not concentric	Re-install the meter
	Straight Pipe Length not enough or the Inner Diameter of Flowmeter Pipe Body do not Match the Pipeline	Check the straight pipe length and the diameter of the pipeline	Re-locate the flowmeter
	Heavy Vibration on the Pipeline	Locate the vibration on the pipeline by touching it with hand	Tighten the pipeline where the flowmeter is installed
	Fluid has not Filled the Pipeline fully	Check the fluid status and the location of the meter.	Re-locate the flowmeter
	Two Phases Flow	Check if there is two-phase flow according to	If the fluid is liquid-solid two-phase flow,

		the pressure and temperature of the fluid.	need to install a filter at upstream of the flowmeter. If the fluid is liquid-gas two phase flow, need to install a getter at upstream of the flowmeter.
	Transmitter Failure	Replace the transmitter with another transmitter of same type to check	Replace the transmitter
A Big Difference Between the Flow Reading and the Process Flow Rate	There is big difference between the flow reading and the process flow rate	Check the density compensation devices and the setting	Fix density compensation
	Wrong Estimated Flow Rate Before use of the Meter	Use another flowmeter to confirm the actual flow rate	
	Setting incorrect	Check the settings of meter K factor, upper and lower limit of flow rate	Set the meter correctly



NOTE

Select the Code Setting, set C49=12. Press the “U-D” button to check the current energy of the vortex flow signal and vibration signal. E1 is the energy of the vortex flow signal; set the energy threshold value lower than the displayed value. E.1 is the energy of vibration; set the energy threshold value lower than the displayed value. Set above value in D017 (energy threshold of the vortex flow signal) and D018 (energy threshold of vibration), then set C49 back to 00

7.2 Self-Diagnostic Messages

Error code	Problem	Repair
Err-003	Temperature Sensor Disconnected	Check Temperature Sensor
Err-004	Pressure Sensor Disconnected	Check Pressure Sensor
Err-005	About to Over Total Flow	This is a Reminder Message
Err-006	Display Value Over Limit	The Value is Over the Physical Limit of the Display

Err-011	Superheated Steam Temperature is Over Limited	Reduce the Steam Temperature
Err-012	Superheated Steam Pressure is Over Limited	Reduce the Steam Pressure
Err-013	Button is Pressed and Hold for too Long Time	Check the Button Circuit
Err-014	Reset Code Setting Failed	Check EEPROM
Err-015	Reset Digit Setting Failed	Check EEPROM
Err-016	Read Total Flow Error	Check EEPROM
Err-017	Temperature Calibration Setting is Wrong	Check the Record of Temperature Calibration
Err-018	Pressure Calibration Setting is Wrong	Check the Record of Pressure Calibration
Err-020	Flow Rate Limit Setting is Incorrect	Check the Flow Rate Limit Setting
Err-021	Temperature Limit Setting is Incorrect	Check the Temperature Limit Setting
Err-022	Pressure Limit Setting is Incorrect	Check the Pressure Limit Setting
Err-023	Communication Connection Error	Check the Communication Link
Err-024	Setting is Incorrect when Using <code>aga_nx_19</code> to Calculate the Compressibility Factor	Check if the Setting for Compressibility Factor is Correct
Err-025	Frequency Output for Total Flow is over Limit	Reset the Total Flow Frequency Output Factor
Err-026	3V Power Source Failure	Check the Circuit Board



TEKMATION LLC reserves the right to change the designs and/or materials of its products without notice. The contents of this publication are the property of TEKMATIION and cannot be reproduced by any other party without written permission. All Rights reserved. Copyright © 2021 TEKMATIION LLC
DOI:TEK/TFS/ML/240520/1300/02
TEKMATION LLC



www.tek-trol.com

Tek-Trol LLC

796 Tek Drive Crystal Lake,
IL 60014, USA



+1 847-857-6076



tektrol@tek-trol.com



www.tek-trol.com

Tek-Trol is a fully owned subsidiary of TEKMATIION LLC. We offer our customers a comprehensive range of products and solutions for process, power and oil & gas industries. Tek-Trol provides process measurement and control products for Flow, Level, Temperature & Pressure Measurement, Control Valves & Analyzer systems. We are present in 15 locations globally and are known for our knowledge, innovative solutions, reliable products and global presence.

Flow | Level | Temperature | Pressure | Valves | Analyzers | Accessories | TekValSys