



Technology Solutions

# TEK-FLUX 1400B

## Insertion Electromagnetic Flow Meter



FLOW



[www.tek-trol.com](http://www.tek-trol.com)

Flow | Level | Temperature | Pressure | Valves | Analyzers | Accessories | TekValSys

## Introduction

Tek-Flux 1400B Electromagnetic Flowmeters are used to measure the flow rate of a variety of conductive liquids. It functions according to the fundamental principle of Faraday's law of Electromagnetic Induction, which describes the relationship between an electrical conductor and the voltage it generates when moving within a magnetic field.

## Measuring Principle

In an Electromagnetic Flowmeter, a magnetic field is generated by a pair of diametrically placed electrical coils mounted external to the flow tube. As the conductive liquid passes through this Electromagnetic field, an electrical voltage is induced in the liquid, which is directly proportional to its velocity. This induced voltage is perpendicular to the directions of both - the liquid flow and the Electromagnetic field.

A pair of diametrically placed electrodes mounted along the inner wall of the flow tube and in the direction of the induced voltage, sense this induced voltage. The sensed voltage is further processed by the Transmitter to indicate the flow rate and generate a standard output signal proportional to the measured flow rate.

## Operation

The flux density of the Electromagnetic field and the distance between the Electrodes are constant for a given flow meter. The induced voltage is therefore only a function of the liquid velocity.

$$E = K.B.V.D$$

Where -

E = Induced voltage

B = Magnetic field strength

K = Flow tube (meter) constant

v = Mean flow velocity

D = Distance between the electrodes

And the volumetric flow is calculated as –

$$qv = (\pi \times D^2/4) \times v$$

Therefore,

$$qv = (\pi \times E \times D) / 4 K B$$

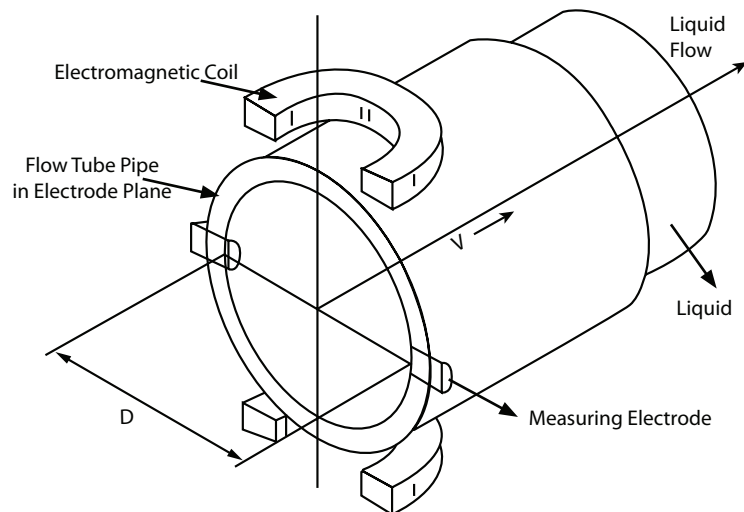

The induced voltage is not affected by the physical properties of the liquid like temperature, viscosity, pressure, density and conductivity, as long as the conductivity of the measured liquid is above a minimum threshold.

## Features

- Adjustable depth
- Can be used in pipes from 4" to 80"
- Comes with isolation valve
- No moving parts
- Multiple signal outputs

## Applications

Tek-Flux 1400B can be successfully deployed in a wide range of industrial liquid flow measurement applications. The major industry sectors include, but not limited to:

- Chemical and Process Industries
- Pharmaceutical Industries
- Sugar and Beverage Industries
- Mining and Dredging Industries
- Water and Waste Water Management

## Dimensional Drawing

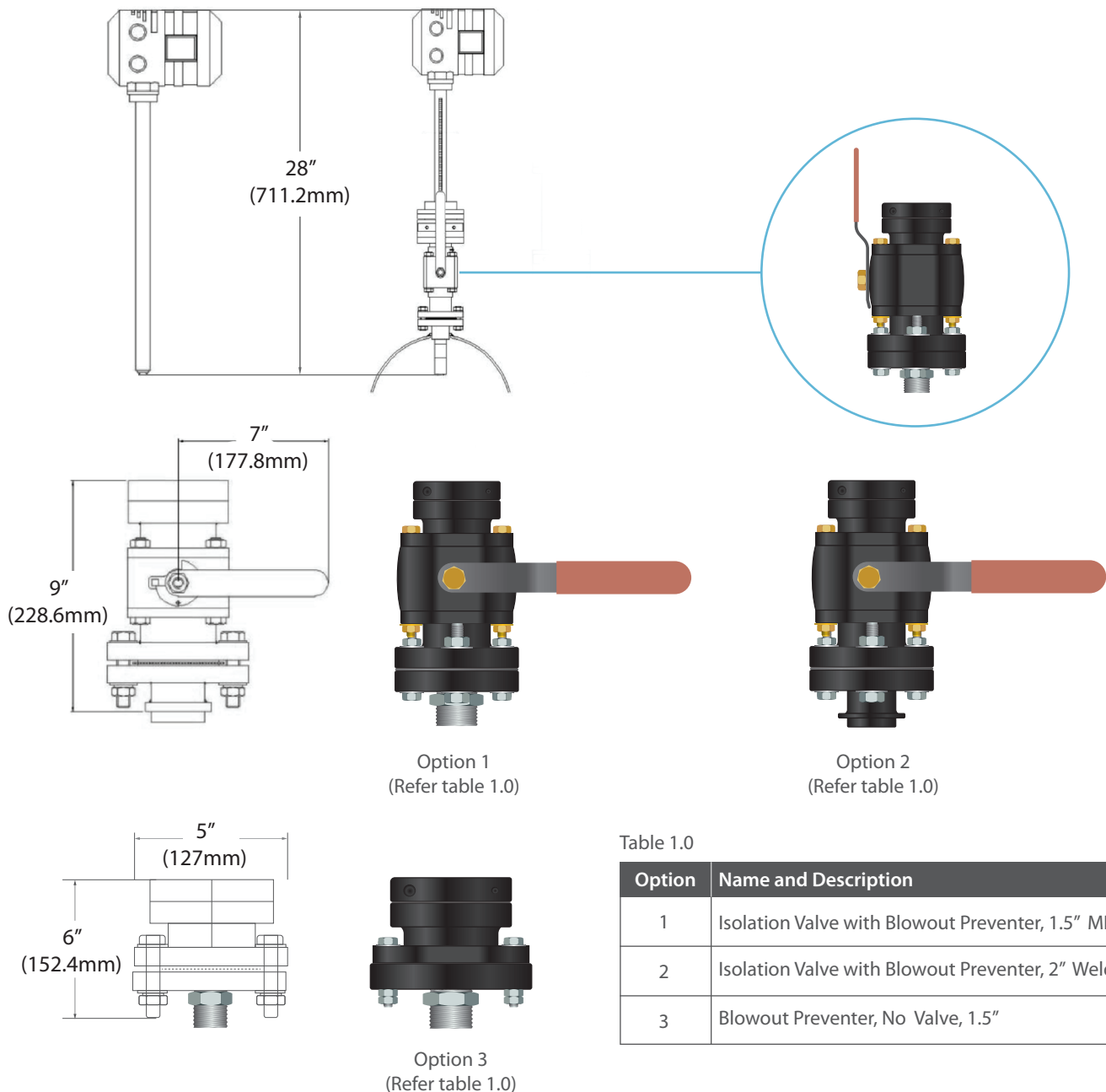
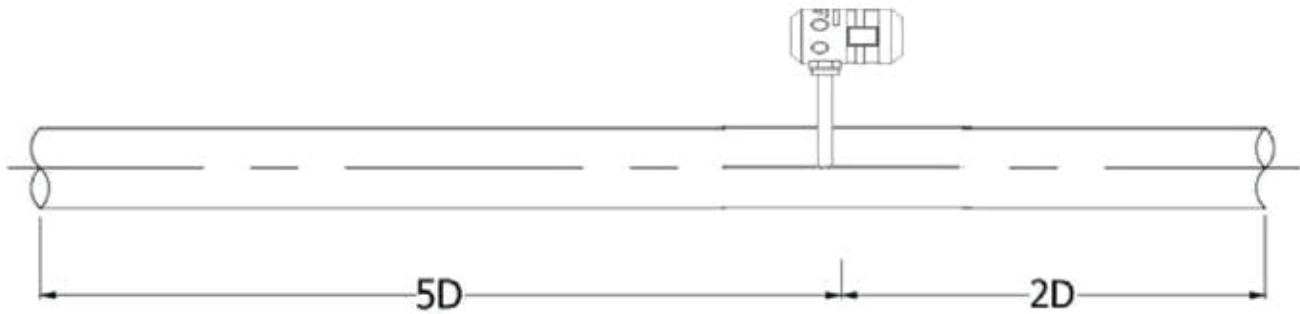
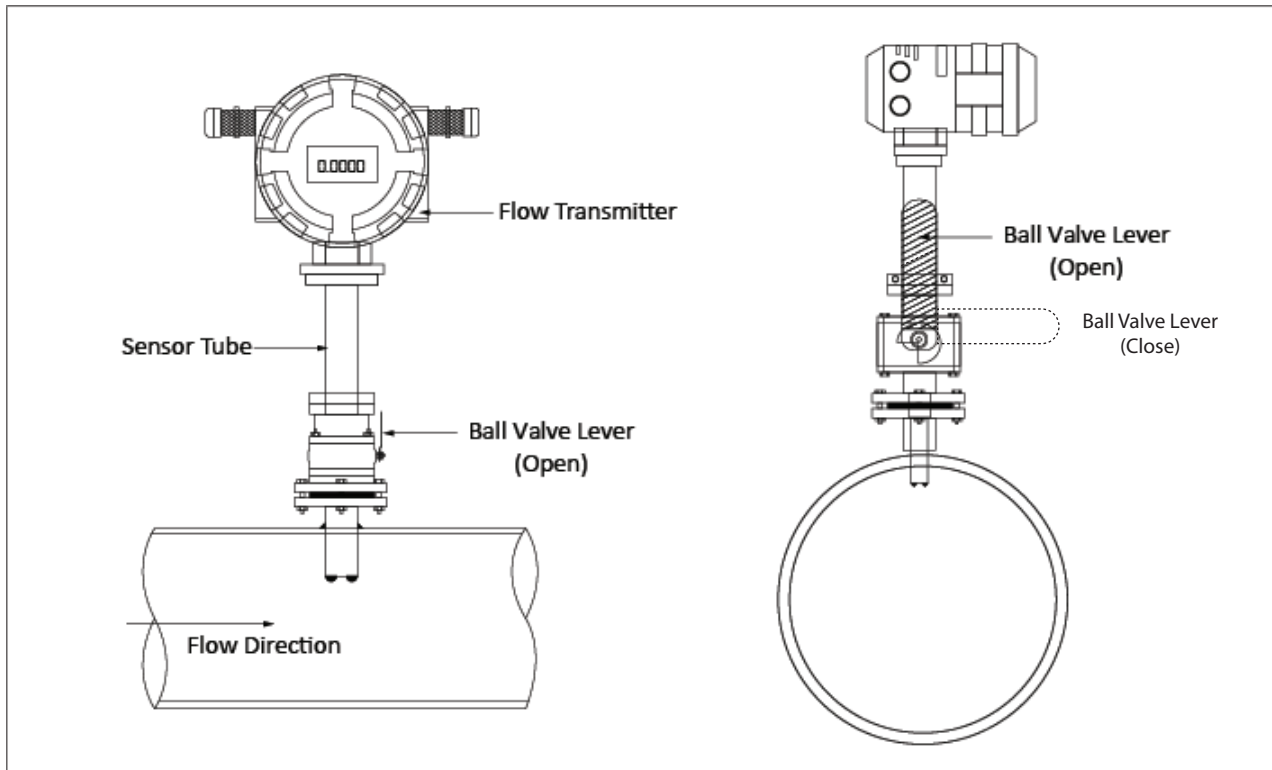

Table 1.0

Option	Name and Description
1	Isolation Valve with Blowout Preventer, 1.5" MNPT
2	Isolation Valve with Blowout Preventer, 2" Weldolet
3	Blowout Preventer, No Valve, 1.5"

## Protecting the Transmitter



At flowmeter upst ream, there should be straight pipe no less than  $5D$  and no less than  $2D$  at flowmeter downstream. ( $D$  is the inner diameter of flowmeter)

## Specifications

<b>Nominal Diameter</b>	4" to 80"	
<b>Working Process Pressure</b>	250psi	
<b>Electrode Material</b>	Hastelloy C	
<b>Wetted Material</b>	316 SS, Hastelloy C, PTFE	
<b>Flow Sensor Rating</b>	IP66, NEMA4X	
<b>Minimum Liquid Conductivity</b>	10 $\mu$ siemens	
<b>Accuracy of Measured Value</b>	$\pm$ 1% of span	
<b>Repeatability</b>	$\pm$ 0.2% of Span	
<b>Measuring Range</b>	0.65 to 39 ft/sec Bi-directional	
<b>Display Version</b>	Integral	
<b>Display Type</b>	16 characters x 2 row LCD, 5 Digit Flow rate and 8 Digit Totalizer	
<b>Units</b>	<b>Flow Rate</b>	<b>Totalizer</b>
	LPS, LPM, LPH, LPD Mlps, Mlpm, Mlph, Mlpd cc/s, cc/m, cc/h, cc/d m <sup>3</sup> /s, m <sup>3</sup> /m, m <sup>3</sup> /h, m <sup>3</sup> /d kg/s, kg/m, kg/h, kg/d t/s, t/m, t/h, t/d gps, gpm, gph, gpd Mgps, Mgpm, Mgph, Mgpd lgps, lgpm, lgph, lgpd lMgps, lMgpm, lMgph, lMgpd ft <sup>3</sup> /s, ft <sup>3</sup> /m, ft <sup>3</sup> /h, ft <sup>3</sup> /d lb/s, lb/m, lb/h, lb/d bbl/d, bbl/h, bbl/s	L, MI, m <sup>3</sup> MI L, MI, cc, m <sup>3</sup> L, MI, m <sup>3</sup> kg, t T G, ft <sup>3</sup> Mg lg, ft <sup>3</sup> lMg g, lg, ft <sup>3</sup> lb bbl
<b>Current Output</b>	4 to 20 mA and Pulse	
<b>Digital Output</b>	Modbus RS485 or HART	
<b>Power Supply</b>	18 to 60 VDC or 80 to 300 VAC	
<b>Electrical Connection</b>	1/2" NPT	
<b>Operating Temperature</b>	-20°F to 250°F (-28°C to 120°C)	
<b>Process Connection</b>	1.5" MNPT or 2" Weldolet	

## Sensor Installation

The flow meter can be installed at any arbitrary location in the pipeline as long as the installation requirements are satisfied. At the same time, care should be exercised when selecting the installation site to assure that moisture cannot enter into the connection area.

- A ball valve assembly with Weld Neck Flange will be supplied in advance.
- A hole of 1.96" diameter is to be made on the pipe line. The Weld Neck Flange is to be welded into the Pipe Line for flow meter installation.
- Put a gasket between Weld neck Flange and Ball Valve Assembly.
- Mount Ball Valve Assembly on the Weld Neck Flange by aligning Weld Neck Flange and Ball Valve Assembly Bottom Flange. Ensure Ball Valve Lever Alignment is with respected to the Flow direction as shown in the figure.
- The Ball Valve Assembly Mounting Bolts are provided (M 10 X 3.93") The mounting bolts are to be tightened. Follow diametrically opposite tightening Sequence.
- Loosen the Collete Clamping Screws provided on the periphery of collect at the Top of Ball Valve Assembly.
- According to the theory of velocity profiles for fully developed turbulent flow in the pipe line, the average velocity point is located at a distance of  $1/8 D$  from the pipe wall where  $D$  is the internal pipe diameter.
- We insert up to 10% of Pipe Diameter.
- Before Sensor is inserted, the insertion length is marked on the Sensor.
  - a) Measure the length of Assembly from Pipe Surface to Collete Top. (Say  $X$ )
  - b) Say Insertion Length is  $Y$ .
  - c) Say Pipe Thickness is  $Z$ .
  - d) Now mark the length of  $X + Y + Z$  starting from Electrodes and up.
- Now open Ball Valve lever fully. Slowly insert the Flow meter's Sensor, passing through the hole.
- Up to the length marked on the Sensor. The Flow Transmitter direction should be as per the drawing.
- Once, the Insertion Length is achieved, tighten the Collete Clamping Screws.
- For the flow meter installation in a pit, for proper installation, commissioning and maintenance of the flow meter, the pit dimensions have to be at least 6.5ft X 6.5ft.
- Kindly ensure that the pit is covered with the protective cover. The pit should be waterproof so that in rainy season it should not get flooded or submerged in water.

## Transmitter Installation

### Integral Type Transmitter

- In case of an Integral Type Flow Meter, the Transmitter comes pre-mounted atop the Flow Sensor and therefore gets physically installed along with the Flow Sensor/sensor.
- The images below show the Integral Type Transmitter mounted on the Flow Sensor.

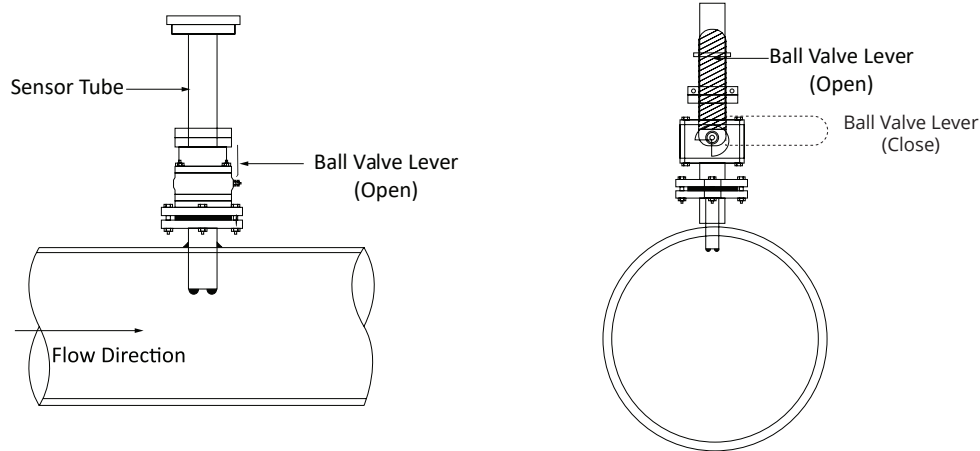

### Protecting the Transmitter

Provide a weather-shade/ canopy to protect the Transmitter from direct exposure to sunlight, rain or any other dropping fluids. This will help enhance the useful life of the Transmitter.

## Electrical Connection

### Instructions for Connecting Cables

Always use cables of the following specifications.

- Power: 3 core, 0.039 inch<sup>2</sup>, PVC/ PTFE sheathed cable
- Current Output: 2 core, 0.039 inch<sup>2</sup>, PVC/PTFE sheathed cable
- Coil and Electrodes (in case of Remote Type Flow Meter): as supplied with Flow Sensor

## Model Chart

Example	Tek-Flux 1400B	1	S	HC	1	1	T	1	#	Tek-Flux 1400B-1-S-HC-1-1-T-1
Series	Tek-Flux 1400B									Insertion Electromagnetic Flow Meter
Transmitter		1 2								Direct Mount Remote Mount
Output			S							4-20mA, Pulse, HART, RS485
Electrodes				HC						Hastelloy C
Insertion Length					1					20" Probe
Power Supply						1 2				18 - 28 VDC 80 - 300 VAC/VDC
Electrode Cap							T			PTFE
Valve Options								1 2 3		Isolation Valve with Blowout Preventer, 1.5" MNPT Process Connection Isolation Valve with Blowout Preventer, 2" Weldolet Process Connection Blowout Preventer, No Valve, 1.5" MNPT Process Connection
Options									IP68	IP68 Submersible Sensor Rating

## Popular Model

Model	Description
1400B-1-S-HC-1-1-T-1	Insertion Electromagnetic Flow Meter, 20" Probe

# Customer Service & Support



TEK-TROL LLC reserves the right to change the designs and/or materials of its products without notice. The contents of this publication are the property of TEK-TROL LLC and cannot be reproduced by any other party without written permission. All rights reserved. Copyright © 2021 TEK-TROL LLC  
TEK-TROL LLC  
DOC # TEK/TIPS/CAT/240520/14008/r04.6



[www.tek-trol.com](http://www.tek-trol.com)

## **Tek-Trol LLC**

796 Tek Drive Crystal Lake,  
IL 60014, USA



+1 847-857-6076



[tektrol@tek-trol.com](mailto:tektrol@tek-trol.com)



[www.tek-trol.com](http://www.tek-trol.com)

Tek-Trol is a fully owned subsidiary of TEKMATIION LLC. We offer our customers a comprehensive range of products and solutions for process, power and oil & gas industries. Tek-Trol provides process measurement and control products for Flow, Level, Temperature & Pressure measurement, Control valves & Analyzer systems. We are present in 15 locations globally and are known for our knowledge, innovative solutions, reliable products and global presence.