



Technology Solutions

TEK-FLUX 1400C

Utility Electromagnetic Flow Meter



FLOW



Battery Powered



NSF

Introduction

Tek-Flux 1400C Utility Electromagnetic Flow Meter is widely used for high-pressure applications with highly accurate and reliable measurements. Tek-Flux 1400C is used to measure flow rate for various conductive liquids. This Inline battery-powered magmeter is specially designed for applications where availability of electricity and power supply is unavailable. The Tek-Flux 1400C Magmeter provides 5 years battery life, which minimize the maintenance and enhance the productivity of smart measurements in field instruments.

Measuring Principle

Tek-Flux 1400C Utility Electromagnetic Flow Meter operates on the principle of Faraday's Law of Electromagnetic Induction. It describes the relationship between an electrical conductor and the voltage generated by a magnetic field. The induced voltage is directly proportional to the velocity of fluid flowing through a magnetic field and passes through the transmitter. The transmitter converts this voltage into a quantifiable flow velocity, where the velocity determines the volumetric flow rate of the fluid.



Fig 1: Tek-Flux 1400C Utility Electromagnetic Flow Meter

In an Electromagnetic Flow Meter, a magnetic field is generated by a pair of diametrically placed electrical coils. These electrical coils are mounted externally to the flow tube. As the conductive liquid passes through this Electromagnetic field, the magnetic field's force causes the negatively and positively charged particles of the liquid to separate. This separation causes an induced voltage between the electrodes and the sensor. This induced voltage is directly proportional to the velocity and perpendicular to both the liquid flow and the electromagnetic field direction. The sensed voltage is further processed by the transmitter to provide a standardized output signal or displayed in an appropriate engineering unit.

Operation

The flux density of the electromagnetic field and the distance between the electrodes are constant. Therefore, the induced voltage is the function of liquid velocity as below:

$$E = K \times B \times v \times D$$

1

Where,

E = Induced Voltage

K = Flow tube Constant

B = Magnetic Field Strength

v = Mean Flow Velocity

D = distance between Electrode

Volume flow is calculated by following equation:

$$Q = \bar{V} \times D^2 \times \pi/4$$

2

From Equation 1 and 2

$$Q = \frac{K \times D \times \pi}{K \times B \times 4}$$

Hence, induced voltage or e.m.f is not affected by the physical properties of liquids such as temperature, pressure, density, and conductivity above the minimum threshold level of measured liquid. When the pipe is completely full of liquid, the flow meter provides reliable and accurate measurements. The electromagnetic field coil assembly is excited by the pulsed DC technique, which eliminates the noise and provides zero correction automatically.

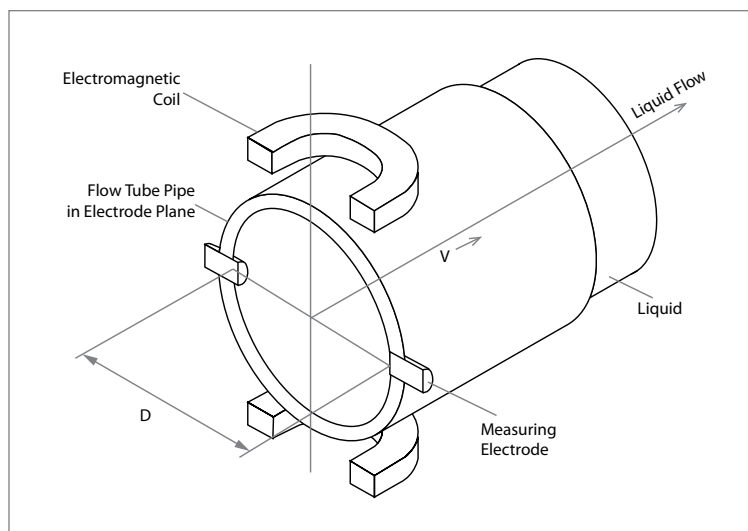

Fig 2: Measuring Principle of Tek-Flux 1400C

Benefits

- No moving parts.
- Provide easy maintenance.
- Coil assembly is hermetically sealed welded construction.
- Integral or remote transmitter.
- Field interchangeable electronics.
- High linearity.
- Absolute zero stability.
- Eliminates noise.
- Battery Powered Device.
- Meters batching and blending totalization.
- Self-diagnostic functions.
- High turndown ratio up to 100:1.
- A backlight LCD with menu setting control and password protection.
- Autoflow compensation.
- Ensure empty pipe detection.
- Ensure zero-point stability and high reliability.

Applications

- Chemical and Petrochemical.
- Fertilizers.
- Pharmaceutical.
- Food and Drug.
- Sugar and Beverage.
- Paper and Pulp.
- Water and Wastewater.
- Dredging.
- Mining.

Specifications

Battery Powered

Accuracy	±0.5% (Standard)
Repeatability	±0.2% of Span
Nominal Diameter	2" to 12" (50 to 300mm)
Nominal Pressure	150# ANSI or 300# ANSI Flange
Working Temperature	Direct: -40 to 250°F (-40 to 120°C) Remote: -40 to 350°F (-40 to 180°C)
Electrode material	316 SS
Sensor Lining	Polypropylene
Display Version	Integral (Optional: Remote)
Measuring tube material	SS 304 Carbon Steel
Transmitter Material	Die Cast Aluminium
End connection	ANSI Flange
Measuring Range	0.7 to 39ft/s (0.2 to 12 m/s) Bidirectional

Output	Pulse and RS485 Modbus
Power Supply	Battery Powered 5 years' Battery Life
Protection Class for Sensor	Std. IP65
Protection Class for Transmitter	IP67
Installation	Inline flanged

• **Line Powered**

Accuracy	±0.5% (Standard); Optional 0.3%	
Measuring Range	0.2 to 12 m/sec Bi-directional	
Repeatability	±0.2% of Span	
Process Pressure	150# ANSI or 300# ANSI Flange	
Process Temperature	Integral: -40 to 250°F (-40 to 120°C) Remote: -40 to 350°F (-40 to 180°C)	
Operating Temperature	-40°F to 131°F (-40°C to 55°C)	
Operating Humidity	5-95% RH non-condensing	
Size	½" to 28" (10mm to 700mm)	
Output	4-20mA, Pulse, HART Modbus RS485	
Power Supply	16 to 60VDC or 80 to 300VAC/DC	
Protection Class	IP65 (Standard), IP68 (Optional for Flow Tube with Remote Transmitter)	
End Connection	ANSI Flange	
Electrode Material	316 SS	
Measuring Tube Material	SS304	
Housing Material	Carbon Steel	
Sensor Lining	Polypropylene	
Display Version	Integral or Remote	
Display Type	16 characters x 2 row LCD, 5 Digit Flow rate and 8 Digit Totalizer	
Units	Flow Rate	Totalizer
	LPS, LPM, LPH, LPD Mlps, Mlpm, Mlph, Mlpd cc/s, cc/m, cc/h, cc/d m³/s, m³/m, m³/h, m³/d kg/s, kg/m, kg/h, kg/d t/s, t/m, t/h, t/d gps, gpm, gph, gpd Mgps, Mgpm, Mgph, Mgpd lgps, lgpm, lgph, lgpd IMgps, IMgpm, IMgph, IMgpd ft³/s, ft³/m, ft³/h, ft³/d lb/s, lb/m, lb/h, lb/d bbl/d, bbl/h, bbl/s	L, MI, m³ MI L, MI, cc, m³ L, MI, m³ kg, t T G, ft³ Mg lg, ft³ IMg g, lg, ft³ lb bbl
Cable Length	30ft (Standard), Up to 150ft Maximum	
Terminal Connector	18 AWG to 22 AWG wire	

Flow Range

- Velocity range - 0.7 ft/sec for minimum and 40 ft/sec for maximum

Line Size	USGPM		m ³ /hr		LPM		LPS	
	Min.	Max.	Min.	Max.	Min.	Max.	Min.	Max.
½" (15)	0.56	33.61	0.13	7.63	2.12	127.21	0.04	2.11
¾" (20)	1	59.75	0.23	13.56	3.77	226.15	0.06	3.77
1" (25)	1.56	93.35	0.35	21.19	5.89	353.36	0.1	5.88
1¼" (32)	2.55	152.95	0.58	34.91	9.65	578.96	0.16	9.65
1½" (40)	3.98	238.98	0.9	54.28	15.08	904.63	0.25	15.07
2" (50)	6.22	373.4	1.41	84.82	23.56	1413.19	0.39	23.56
2½" (65)	10.52	631.06	2.39	143.28	39.82	2389.2	0.66	39.8
3" (80)	15.93	955.92	3.62	217.08	60.31	3618.55	1.01	60.3
4" (100)	24.89	1493.63	5.65	339.24	94.23	5653.99	1.57	94.22
5" (125)	38.9	2333.8	8.84	530.16	147.24	8834.38	2.45	147.24
6" (150)	56.01	3360.66	12.72	763.32	212.03	12721.5	3.53	212.02
8" (200)	99.58	5974.51	22.6	1356	376.93	22616	6.28	376.93
10" (250)	155.59	9335.18	35.2	2112	588.96	35337.5	9.82	588.96
12" (300)	224.04	13442.65	50.89	3053.16	848.1	50886	14.14	848.1

Dimensional Drawings

- **Battery Powered**

Material of Construction	
Pipe Material	Carbon Steel
Electrode Material	316 SS
Flanges	Carbon Steel
Coil Housing	Carbon Steel
Flow Transmitter	Die Cast Aluminium
Liner	Polypropylene

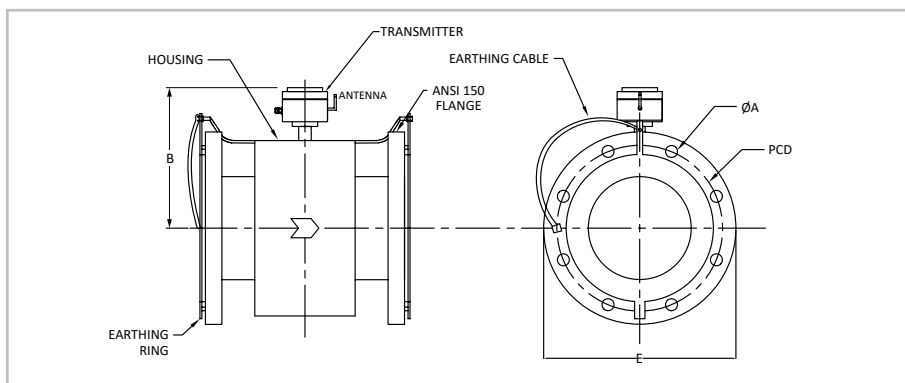

Fig 3: Battery Powered

Line Size in (mm)	D in (mm)	B in (mm)	E in (mm)	Flange OD	PCD	Ø A X NO. OF HOLES
2"(50)	8" (200)	9 ½" (239)	7" (175)	6" (150)	4 ¾" (121)	Ø19 X 4
2 ½" (65)	8" (200)	9 ¾" (245)	7 ½" (187)	7 ¼" (180)	5 ½" (140)	Ø19 X 4
3" (80)	8" (200)	10 ⅛" (253)	8 ⅛" (203)	7 ½" (190)	6" (152)	Ø19 X 4
4"(100)	10" (250)	10 ¾" (268)	9 ¼" (234)	9 ¼" (230)	7 ½" (190)	Ø19 X 8
5" (125)	10" (250)	11 ½" (287)	10 ¾" (272)	10 ¼" (255)	8 ¾" (216)	Ø23 X 8
6" (150)	12" (300)	12 ¼" (305)	12 ¼" (308)	11 ¼" (280)	9 ½" (241)	Ø23 X 8
8" (200)	14" (350)	13 ¼" (331)	14 ¼" (359)	13 ¾" (345)	12" (298)	Ø23 X 8
10" (250)	16" (400)	14 ¼" (358)	16 ½" (413)	16 ¼" (405)	14 ½" (362)	Ø25 X 12
12" (300)	20" (500)	14 ¾" (368)	19 ½" (485)	19 ½" (485)	17 ¼" (432)	Ø25 X 12

- Line Powered**

Flow Tube with Metal body

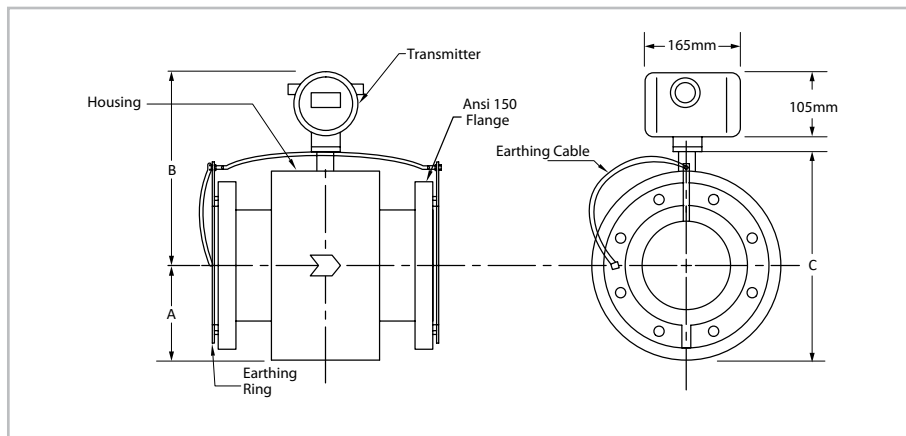

Fig 4: Integral Type

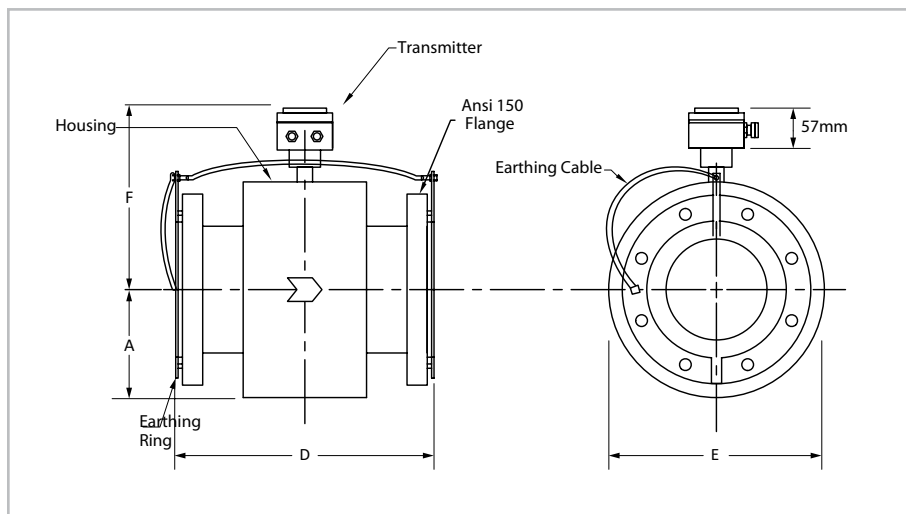

Fig 5: Remote Type

Line Size in (mm)	A in (mm)	B in (mm)	C in (mm)	D in (mm)	E in (mm)	F in (mm)
½" (15)	2 ¼" (58)	9 ¼" (233)	6 ½" (165)	8" (200)	4 ½" (115)	6 ½" (165)
¾" (20)	2 ¾" (70)	9 ¾" (245)	7 ½" (190)	8" (200)	5 ¼" (140)	7" (177)
1" (25)	2 ¾" (73)	9 ⅞" (248)	7 ¾" (195)	8" (200)	5 ¾" (145)	7 ¼" (180)
2" (50)	3 ½" (88)	10 ½" (263)	9" (225)	8" (200)	7" (175)	7 ¾" (195)
2 ½" (65)	3 ¾" (94)	10 ¾" (269)	9 ½" (237)	8" (200)	7 ½" (187)	8" (201)
3" (80)	4 1/8" (104)	11" (277)	10 1/8" (253)	8" (200)	8 1/8" (203)	8 ¼" (209)
4" (100)	4 ¾" (117)	11 ¾" (292)	11 ¼" (284)	10" (250)	9 ¼" (234)	9" (224)
5" (125)	5 ½" (136)	12 ½" (311)	12 ¾" (322)	10" (250)	10 ¾" (272)	9 ¾" (243)
6" (150)	6 ¼" (154)	13 ¼" (329)	14 ¼" (358)	12" (300)	12 ¼" (308)	10 ½" (261)
8" (200)	7 ¼" (180)	14 ¼" (355)	16 ¼" (409)	14" (350)	14 ¼" (359)	11 ½" (287)
10" (250)	8 ¼" (207)	15 ¼" (382)	18 ½" (463)	16" (400)	16 ½" (413)	12 ½" (314)
12" (300)	9 ¾" (243)	15 ¾" (392)	20 ½" (510)	20" (500)	19 ½" (485)	13" (324)
14" (350)	10 ¾" (268)	17" (423)	22 ¾" (567)	20" (500)	21 ½" (535)	14 ¼" (355)
16" (400)	12" (298)	18" (448)	24 ¾" (621)	24" (600)	23 ¾" (595)	15 ¼" (380)
18" (450)	12 ¾" (318)	19" (474)	26 ¾" (666)	24" (600)	25 ½" (635)	16 ¼" (406)
20" (500)	14" (350)	20" (499)	29" (724)	24" (600)	28" (700)	17 ¼" (431)
24" (600)	16 ¼" (408)	23 ¼" (582)	34 ½" (865)	24" (600)	32 ½" (815)	20 ½" (514)
28" (700)	18" (448)	23 ½" (590)	35 ¼" (883)	28" (700)	35 ¾" (895)	20 ¾" (522)
32" (800)	20 ¼" (508)	26" (650)	40" (1000)	32" (800)	40 ½" (1015)	23 ¼" (582)
36" (900)	22 ¼" (558)	27 ¼" (683)	42 ¾" (1066)	36" (900)	44 ½" (1115)	24 ½" (615)
40" (1000)	24 ¼" (615)	29" (724)	48 ½" (1214)	40" (1000)	49 ¼" (1230)	26 ¼" (655)

Approximate Weight Chart							
Line Size (inch)	Line Size (mm)	Net Weight (lb)	Net Weight (kg)	Gross Weight with packaging (lb)	Gross Weight with packaging (kg)	Box Dimension in inch (for 1 Magmeter)	Box Dimension in mm (for 1 Magmeter)
1/2	15	11	5	26	12	23.6*15.4*17.4	600*390*440
3/4	20	13	6	26	12		
1	25	13	6	26	12		
1.25	32	18	8	31	14		
1.5	40	18	8	31	14		
2	50	22	10	35	16		
2.5	65	29	13	42	19		

3	80	33	15	46	21	23.6*15.4*17.4	600*390*440
4	100	44	20	64	29		
5	125	57	26	70	32		
6	150	68	31	84	38		
8	200	99	45	154	70	24.6*23.2*22.8	625*540*580
10	250	136	62	209	95	26.8*23.4*25.2	675*590*635
12	300	211	96	286	130	29.7*26.2*28.2	750*660*710
14	350	253	115	330	150	34.7*27.3*28.6	875*690*720
16	400	341	155	418	190	35.7*32.5*31.74	900*820*800
18	450	352	160	440	200	36.9*31.4*32.7	930*790*825
20	500	506	230	616	280	37.7*34.5*32.9	950*870*830
24	600	682	310	814	370	44.4*41.26*33.73	1120*1040*850
28	700	836	380	990	450	45.8*39.7*36.5	1155*1000*920
32	800	1122	510	1298	590	46.4*46.4*51.42	1170*1170*1050
36	900	1320	600	1540	700	50.8*50.8*46.0	1280*1280*1160
40	1000	1892	860	2134	970	64.7*57.2*48.4	1630*1440*1220

Installations

Flow tube must be full of liquid to avoid erratic measurement results. Ensure the Electrodes axis is horizontal within ± 15 degrees. Ensure straight pipe lengths on both sides of the flow tube (5D at upstream and 3D at downstream from the center of the flow tube).

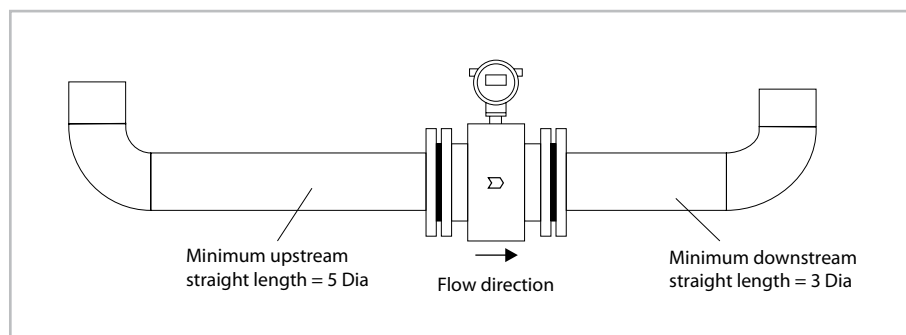

Fig 6: Straight Run Requirement

Flow tube may be installed in horizontal pipelines preferably, with a slight upward gradient in the direction of flow.

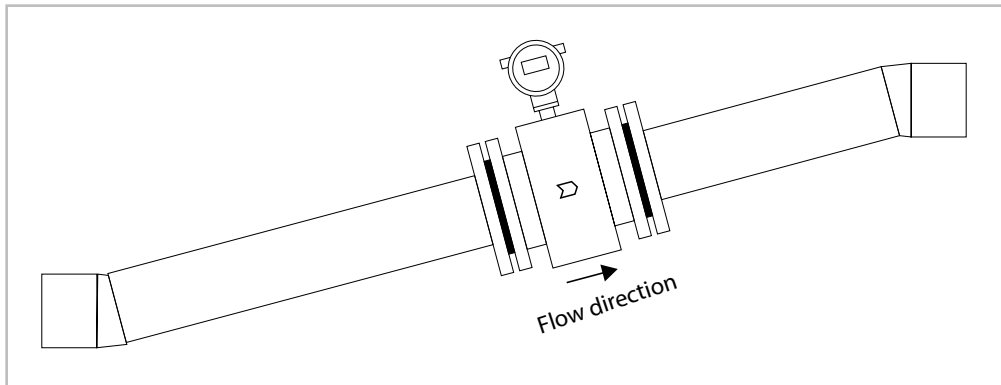

Fig 7: Horizontal Installation

Never install the flow tube in an empty or partially full pipeline. Never install the flow tube in vertical pipelines, where the liquid flow direction is downward.

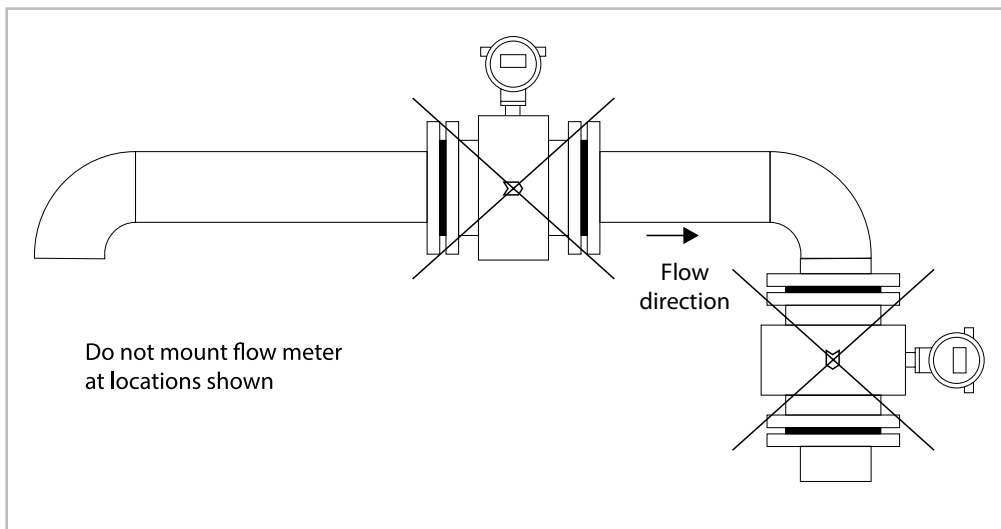

Fig 8: Vertical Installation with Liquid in the Downward Direction

Model Chart

Example	Tek-Flux 1400C	080	1	S	SS	1	2	PY	NSF	Tek-Flux 1400C-80-1-S-SS-1-2-PY-NSF
Series	Tek-Flux 1400C									Utility Magmeter
Size		15 25 40 50 65 80 100 150 200 250 300 450 500 600 700								½" 1" 1 ½" 2" 2 ½" 3" 4" 6" 8" 10" 12" 18" 20" 24" 28"
Transmitter			1 2							Direct Mount Remote Mount (comes with 30 ft. of cable)
Output				B S						Pulse, Modbus RS-485 (Battery Powered) 4-20mA HART, Pulse, Modbus RS-485
Electrodes					SS X					316 SS Consult Factory
Process Connection						1 3				150# ANSI Flange 300# ANSI Flange
Power Supply							1 2 3			Battery 16 to 60VDC 80 to 300 VAC/VDC
Liner								PY		Polypropylene
Options									IP68 NSF EA	IP68 Submersible Sensor Rating (Remote Only) NSF Approved Extended Accuracy (0.3%)

Customer Service & Support



TEK-TROL LLC reserves the right to change the designs and/or materials of its products without notice. The contents of this publication are the property of TEK-TROL LLC and cannot be reproduced by any other party without written permission. All rights reserved. Copyright © 2022 TEK-TROL LLC
TEK-TROL LLC
DOC # TEK/ITPS/CAT2.40520/1400C/01.4



www.tek-trol.com

Tek-Trol LLC

796 Tek Drive Crystal Lake,
IL 60014, USA



+1 847-857-6076



tektrol@tek-trol.com



www.tek-trol.com

Tek-Trol is a fully owned subsidiary of TEKMATIION LLC. We offer our customers a comprehensive range of products and solutions for process, power and oil & gas industries. Tek-Trol provides process measurement and control products for Flow, Level, Temperature & Pressure measurement, Control valves & Analyzer systems. We are present in 15 locations globally and are known for our knowledge, innovative solutions, reliable products and global presence.