



TEK-DP 1610A

Single Chamber Orifice Fitting

Instruction Manual

Document Number: IM-1610A

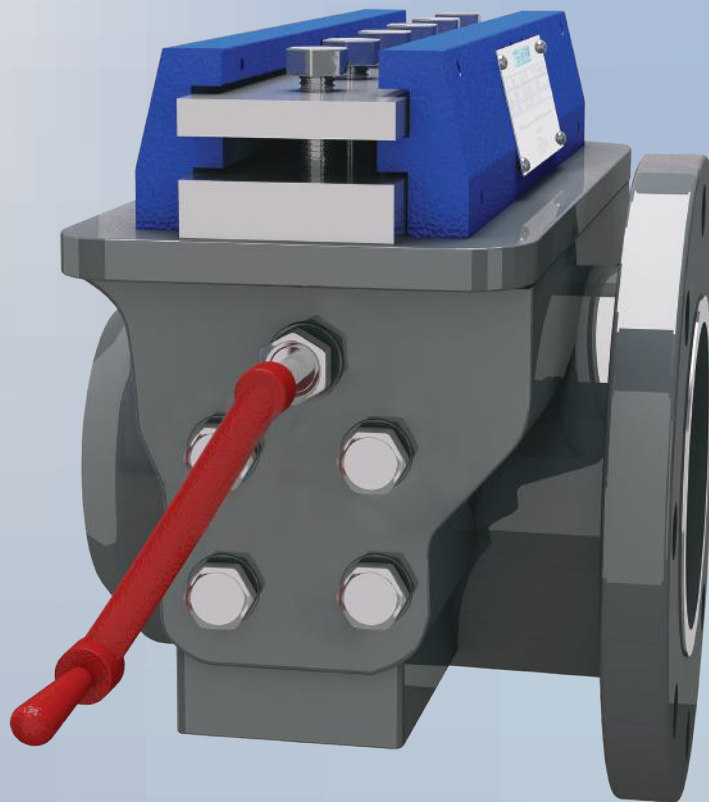

www.tek-trol.com

NOTICE

Read this manual before working with the product. For personal and system safety, and for optimum product performance, make sure you thoroughly understand the contents before installing, using, or maintaining this product.

For technical assistance, contact

Customer Support

796 Tek-Drive

Crystal Lake, IL 60014

USA

Tel: +1 847 857 6076, +1 847 655 7428

© COPYRIGHT Tek-Trol LLC 2016

No part of this publication may be copied or distributed, transmitted, transcribed, stored in a retrieval system, or translated into any human or computer language, in any form or by any means, electronic, mechanical, manual, or otherwise, or disclosed to third parties without the express written permission. The information contained in this manual is subject to change without notice.

Table of Contents

1	Safety Instructions.....	2
1.1	Intended Use	2
1.2	Safety Instructions from the Manufacturer	2
1.2.1	Disclaimer	2
1.2.2	Product Liability and Warranty	2
1.2.3	Information Concerning the Documentation	3
1.3	Safety Precautions.....	3
1.4	Packaging, Transportation and Storage.....	4
1.4.1	Packaging.....	4
1.4.2	Transportation	4
1.4.3	Storage	4
1.4.4	Nameplate	4
2	Product Description.....	5
2.1	Introduction	5
2.2	Measuring Principle.....	6
2.3	Operation.....	7
2.4	Technical Specification.....	7
2.5	Dimensional Drawings	8
3	Installation.....	9
3.1	Considerations to be taken before Installation	9
3.2	Single Chamber Orifice Fitting Installation.....	9
3.3	Line Pressure Test	10
3.4	Orifice Plate Installation	11
4	Operation	12
4.1	Plate Removal	12
4.2	Plate Replacement	13
5	Maintenance.....	14

1 Safety Instructions

1.1 Intended Use

The Tek-DP 1610A Single Chamber Orifice Fitting containing an orifice plate is used as a mean of generating a differential pressure in a range of gas/liquid flow measurement applications. Built on the oldest and proven differential pressure measurement technique, the Tek-DP 1610A Single Chamber Orifice Fittings are constructed to allow ease of orifice plate replacement, reliable measurement and exceptional performance.

Tek-Trol provides a comprehensive orifice metering solution by assembling orifice fittings with upstream/downstream meter runs, an orifice plate and a flow conditioner (or a straightening vane) in accordance with the latest AGA 3 and ISO 5167 standards. Tek-Trol supplies a complete orifice metering system or the individual components as per customer's requirement. All components of orifice meters are available in a complete range of materials, sizes, and pressure ratings to meet the application needs.

1.2 Safety Instructions from the Manufacturer

1.2.1 Disclaimer

No part of this document may be reproduced in any form or by any means, electronic or mechanical, including photocopying, without the express written permission of Tek-Trol LLC. All pertinent state, regional and local safety regulations must be observed when installing and using this product. For reasons of safety and to help ensure compliance with documented system data, only the manufacturer should perform repairs to components.

Before installation, commissioning, and operation, ensure that the appropriate model has been selected in terms of measuring range, design, and specific measuring conditions. Non-observance can result in serious injury and/or damage to the equipment.

1.2.2 Product Liability and Warranty

Tek-Trol warrants these products for a period of two years from the date of shipment and 18 months from the date of installation. All products manufactured by the seller are free from defects of material and workmanship when used within the service, range, and purpose for which they were manufactured.

Seller will, at its option, repair, replace, or refund the purchase price of parts if found to be defective in material or workmanship provided that Seller receives a written notice of such defect requesting repair, replacement, or refund within the warranty period and provided that any instructions thereafter given by Seller are complied with. This warranty does not extend to anyone other than the original Buyer from the Seller.

1.2.3 Information Concerning the Documentation

The information provided in this documentation contains general descriptions and/or technical characteristics of the performance of the products contained herein. This documentation is not intended as a substitute and is not to be used for determining suitability or reliability of these products for the specific user applications. It is the duty of any such user or integrator to perform the appropriate and complete risk analysis, evaluation, and testing of the products with respect to the relevant specific application or use thereof. Neither Tek-Trol LLC nor any of its affiliates or subsidiaries shall be responsible or liable for misuse of the information contained herein. If you have any suggestions for improvements or amendments or have found errors in this publication, please notify us.

1.3 Safety Precautions

Read these instructions carefully and look at the equipment to become familiar with the device before trying to install, operate, service, or maintain it. The following special messages may appear throughout this documentation and on the equipment to warn of potential hazards or to call attention to information that clarifies or simplifies the procedure.



WARNING

Indicates a potentially dangerous situation that can result in serious injury or death, if not avoided.



CAUTION

Indicates a potentially dangerous situation that can result in minor injuries or damage to equipment or the environment, if not avoided.



NOTE

Indicates useful tips, recommendations and information for efficient and trouble-free operation.

1.4 Packaging, Transportation and Storage

1.4.1 Packaging

Do not remove packaging until just before mounting the instrument. It is recommended to store the packaging, as it will provide optimum protection during transport (e.g. change in location, sending for repair).

The original manufacturer's package consists of

1. Tek-DP 1610A Single Chamber Orifice Fitting (1 Unit)
2. Accessories: Orifice plate carrier, orifice plate (1 Unit)
3. Documentation: Instruction Manual, Quick Start Guide

1.4.2 Transportation

Check the Tek-DP 1610A Single Chamber Orifice Fitting for any damage that may have been caused during transport. Obvious damages must be reported immediately.

- Avoid impact shocks to the device and prevent it from getting wet during transportation.
- Verify local safety regulations, directives, and company procedures with respect to hoisting, rigging, and transportation of heavy equipment.
- Transport the product to the installation site using the original manufacturer's packing whenever possible.

1.4.3 Storage

Permissible storage temperature at the place of storage: -22 °F to 176 °F
Store the Tek-DP 1610A Single Chamber Orifice Fitting and all other components (gaskets, bolts, screws etc.) in the original packing material.

1.4.4 Nameplate

The nameplate lists the order number and other important information, such as design details and technical data.



Check the device nameplate to ensure that the device is delivered according to your order.

		
Line Bore	ASNC Rating	C.W.P.
Model Number	Serial Number	Material ASTM
Plate Seal Gap	Plate Thickness	Trim
<p>WARNING: Pressurized unit- STAY CLEAR OF OPENING WHILE OPERATING- SAFETY FIRST</p> <p>www.tek-trol.com 796 Tek Drive Crystal Lake, IL60014 USA Tel: +1 8478576076, +1 8476557428 Fax: +1 8476556147</p>		

2 Product Description

This section covers the reference and specification data, as well as the ordering information.

2.1 Introduction

The Tek-DP 1610A Single Chamber Orifice Fittings are the single chamber devices used for securely holding an orifice plate in the fluid flow line to achieve precise flow measurement. These fittings allow ease of orifice plate replacement or inspection in a depressurized flow line without physically removing the meter from the line.

The Tek-DP 1610A Single Chamber Orifice fittings are best used in the applications where replacing the orifice plate under pressure conditions is risky and a nominal shutdown time is acceptable. The single chamber fittings are manufactured in accordance with ANSI, AGA/API, and ASTM standards for pressure tap integrity, positive plate seal, seal protrusion and eccentricity. These single chamber orifice fittings can be installed in vertical or horizontal lines and are available in a wide range of pipe sizes from 2" to 48".

The plate removal procedure does not require removal of the flange bolts or spreading of flanges. This prevents potential leakage of process fluid and safeguards the operators.



Fig.1. Single Chamber Orifice

For the smaller models of size 2" to 6", by removing bolts and a camping bar, the operator can easily pull the orifice plate from the fitting, inspect and replace in a short time. However, 8" and larger models incorporate a rack and pinion gear system to handle the sizable weight of large orifice plates and carriers.

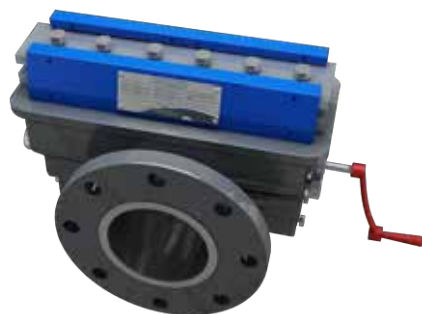

Fig.2. Rack and Pinion Gear System



Fig.3. Carrier Plate

The Tek-DP 1610A Single Chamber Orifice Fittings allow an accurate and secured positioning of the plate every time it is replaced after inspection ensuring the unchanged meter performance. The standard O-ring seals used in these fittings provide superior sealing capability by eliminating the requirement of gasket maintenance and possibility of screw breakage. However, gaskets are available to use when required.

2.2 Measuring Principle

The Tek-DP 1610A Single Chamber Orifice Fittings work on the principle of differential pressure measurement. The orifice plate placed inside the Single Chamber Orifice Fitting is responsible to create obstruction to the flow of fluid. Based on Bernoulli's theory of conservation of mass and energy in a closed pipe, the obstruction to the flow of fluid leads to an increase in the flow velocity (i.e. $V_2 > V_1$), thereby creating a pressure drop. The fluid flow rate depends on the static pressures at upstream and downstream, minimum cross sectional area and temperature. It is calculated by applying the law of conservation of mass and energy.

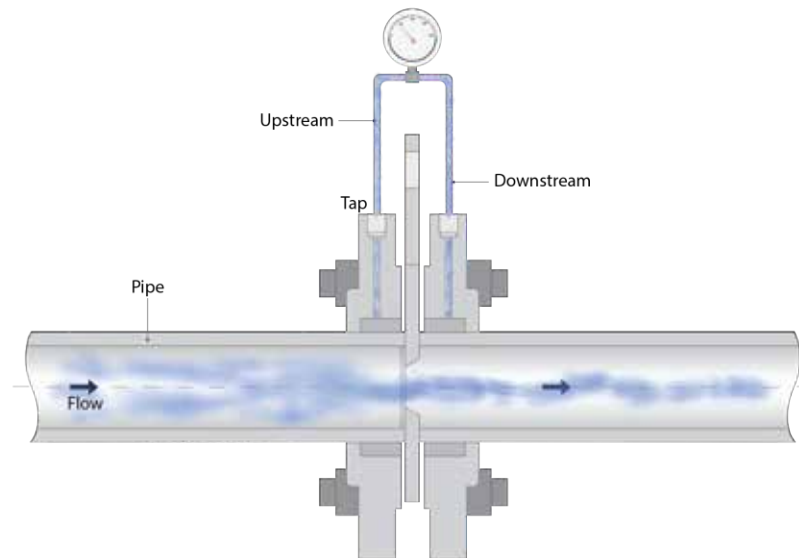

Fig.4. Differential Pressure Measurement

The relation between the differential pressure and flow rate is represented as the below expression,

$$\Delta p \propto Q^2$$

The differential pressure generated, Δp , is proportional to the square of mass flow rate, Q . In simple terms, for a given size of restriction, higher the differential pressure, Δp , higher is the flow rate, Q .

2.3 Operation

The complete orifice meter assembly is comprised of an orifice plate that is positioned between the two flanges with the help of an orifice plate carrier and other essential components such as the flow conditioner, pressure taps and the transmitter. The orifice plate acts as a restriction to the flow of the fluid.

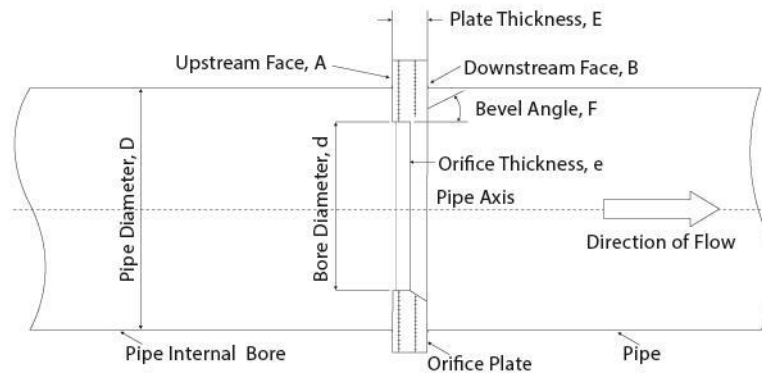

Fig.5. Operation of an Orifice Flowmeter

The fluid in motion passes through an abrupt obstruction created by the orifice plate. This results in a sudden pressure drop, which varies with the flow rate. As the fluid converges to pass through the bore, its velocity increases. The flow continues to converge at the downstream of the plate until it reaches the vena contracta point (the point of maximum convergence) and then expands to rejoin the pipe wall. The pressure taps measure static pressures of the upstream and downstream flow. The differential pressure is proportionate to the flow rate and can be determined by the equations defined in defined in AGA 3 and ISO 5167 standards.

2.4 Technical Specification

Body Materials	A216 WCB, A216 WCC, A352 LCC, A358 CF8M, A995 Gr4A, A995 Gr6A, Custom materials available
Internal Parts	AISI 4130 Carbon Steel, 316 or A351 Stainless Steel
Tap Connections	Two ½" NPT per side standards, 4 pairs available as option
Fitting Sizes and ANSI Class	2" to 48", 150 to 2500 ANSI, Larger sizes available on request
Operating Temperature	Standard -20 °F to 100 °F (-28 °C to 37 °C), optional -40 °F to 1200 °F (-40 °C to 648 °C)
Orientation	Vertical or Horizontal
Process Media	Liquids and Gases
Line Bore I.D. Tolerance	In conformance with AGA-3 and ISO-5167 Latest Edition
Eccentricity Repeatability	In conformance with AGA-3 and ISO-5167 Latest Edition

2.5 Dimensional Drawings

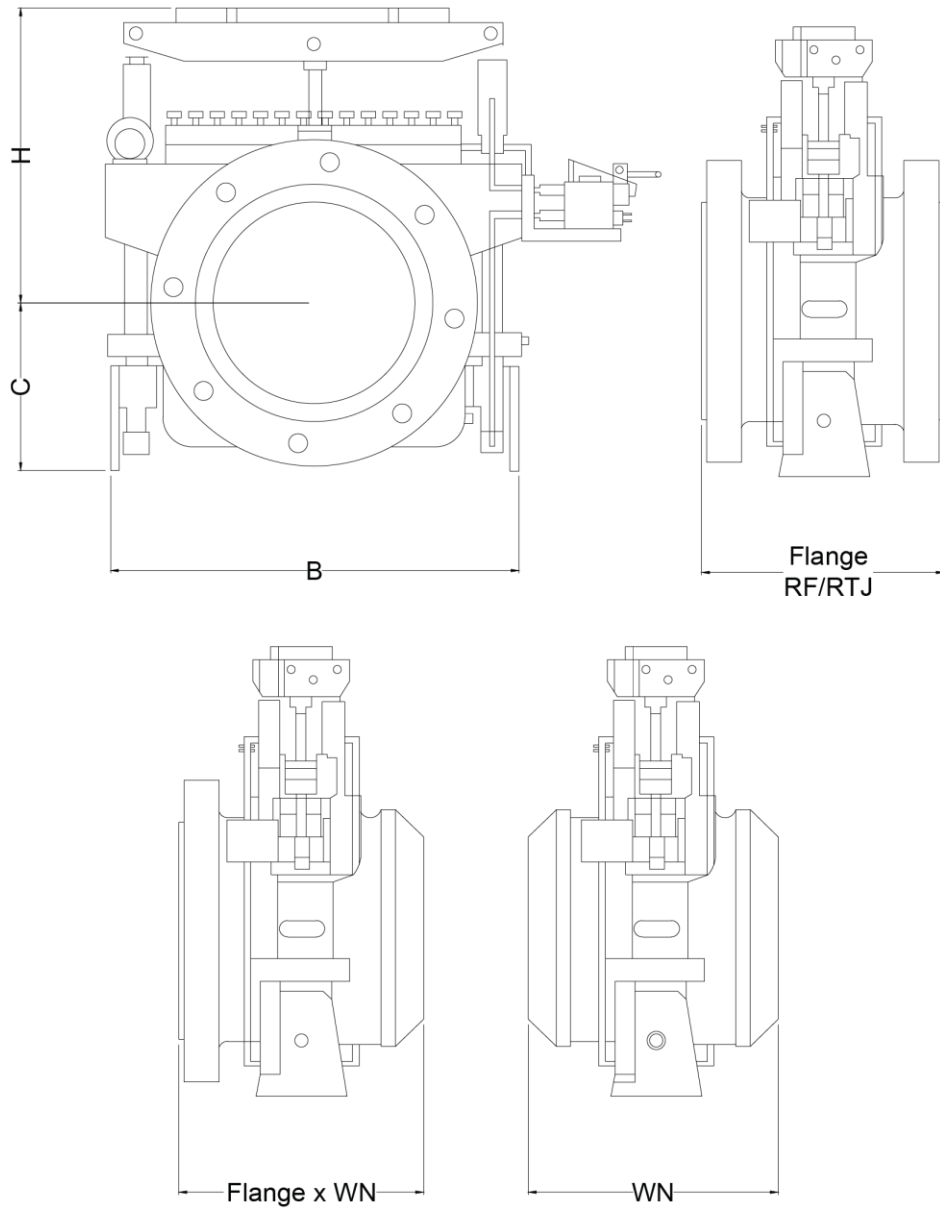

Fig.6. Dual Chamber Orifice Flowmeter

3 Installation

This section covers instructions on installation and commissioning of the instrument. Trained, and qualified specialists authorized to perform such work must carry out installation of the device.



CAUTION

- Ensure that the operating staff is competent and trained to operate this pressurized equipment.
 - Ensure that the installation personnel confirm the maximum allowable operating pressure of each item in the system before pressurizing the system.
-

3.1 Considerations to be taken before Installation

The Tek-DP 1610A Single Chamber Orifice Fitting is an essential element of the orifice measurement system. Other elements of the orifice measurement system include an orifice plate, a meter tube, a flow conditioner, and a data-recording device (DP transmitter). The Tek-DP 1610A Single Chamber Orifice Fitting is typically installed between the upstream and downstream orifice meter runs, in compliance with the AGA-3 / API 14.3 and ISO 5167-1 specifications to ensure adequate length and precise alignment. In addition to these standards, follow the installation guidelines recommended in section 3.2 to obtain the best measurement performance.

When installing only a Tek-DP 1610A Single Chamber Orifice Fitting in an existing system, it is the responsibility of the product owner and product operating personnel to ensure the compatibility of the meter assembly and the fitting prior to service.

3.2 Single Chamber Orifice Fitting Installation

- A. Identify the fitting location and install it in the piping system with due consideration of the following
 - Internal/external pressure
 - Ambient and operating temperatures
 - External factors such as wind, rain, lightning
 - Possible damage from external fire
 - Reaction forces resulting from supports and piping, etc.
 - Corrosion or erosion due to process fluids
- B. Clear all foreign material such as dirt, welding chips, scale, grease from the piping, fitting surfaces, internal cavities and connections that may have collected during manufacturing, shipment, storage or line installation.
- C. It is possible to install the fitting in either horizontal or vertical position. Use of vertical mount is recommended for wet gas measurement to prevent moisture formation against the orifice plate.

- D. For the installation in either direction, ensure that the flow arrow on the outer surface of the fitting corresponds to the direction of flow in the pipeline.
- E. Install the Single Chamber Orifice Fitting between the upstream and downstream meter run sections. Place the fitting in line with the two 1/2" NPT flange taps, positioning the instruction plate facing upward.
- F. Install the sealing bar gasket, sealing bar and clamping bar. Tighten all bolts and screws to the adequate torque.
- G. Provide sufficient operating clearance for the fitting: Top clearance for removal of the orifice plate and side clearance for operating the pinion gear system. Also, provide adequate clearances for all secondary equipment such as process taps, drain plug.

3.3 Line Pressure Test

After installing the Tek-DP 1610A Single Chamber Orifice Fitting into the process line, it is recommended to perform a line pressure test and a leak test.

- A. Install a pressure gauge on the orifice metering system to detect the fluid pressure inside the line. Select an appropriate pressure gauge rated for the maximum operating pressure of the system.
- B. Slowly pressurize the system with the process fluid at a rate of 1 psig per second and then stop pressurization when the pressure reaches 20 psig. Hold the system at this pressure for 5-7 minutes.
- C. During the hold-period, apply a leak-detection solution all over the system including the connections, taps and joints.
- D. If leakage is detected, then mark the leak area and depressurize the system to zero (0) psig.
- E. Repair the leak spot by tightening screws and connectors. Repeat the leak test until no leakage is detected. If the leakage persists even after several attempts, contact Tek-Trol representative immediately.
- F. Once the leak test is complete without leaks detected, start pressurizing the line at the rate of 10 psig per second until the pressure reaches the maximum operating pressure of the system. Hold the system at this pressure of 10 minutes.
- G. During the hold-period, apply a leak-detection solution all over the system including the connections, taps and joints.
- H. If leakage is detected, then mark the leak area and depressurize the system to zero (0) psig.
- I. Repair the leak spot by tightening screws and connectors. Repeat the leak test until no leakage is detected. If the leakage persists even after several attempts, contact Tek-Trol representative immediately.
- J. Once the line pressure test is complete successfully, slowly depressurize the system until the gauge reads zero (0) psig.

The Tek-DP 1610A Single Chamber Orifice Fitting is now ready for orifice plate installation and operation in a fully pressurized line.

3.4 Orifice Plate Installation

The Tek-DP 1610A Single Chamber Orifice Fitting is shipped with the plate-carrier installed within and the orifice plate (if ordered) is shipped in a separate package.

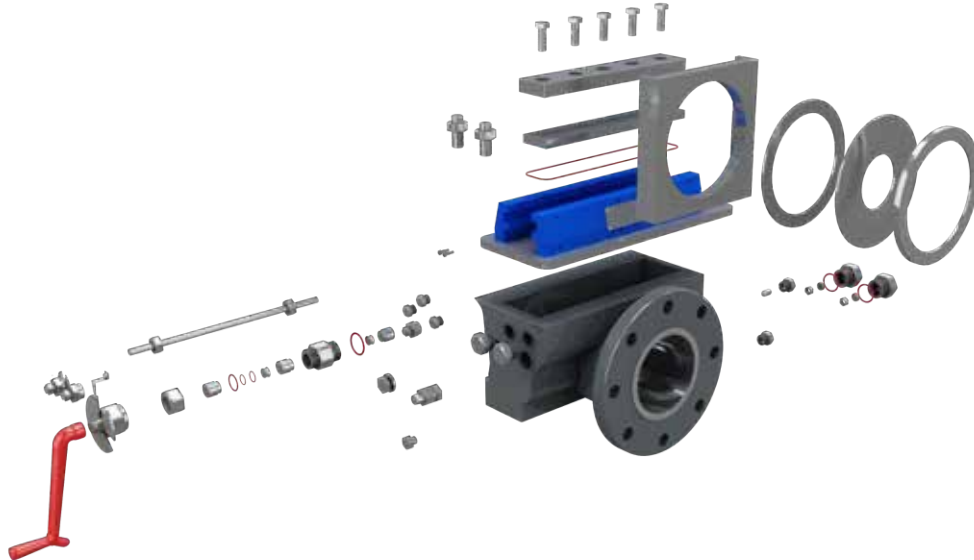

Fig. 8. Single exploded View

- A. Ensure that the orifice metering system is completely depressurized to being orifice plate installation and the pressure inside the Single Chamber Orifice Fitting and adjacent components is equivalent to atmospheric pressure.
- B. Loosen the clamping bar screws; do not remove the clamping bar completely.
- C. Lightly tap the sealing bar to break the sealing bar gasket seal.
- D. Slide out the clamping bar from the fitting body and lift out the sealing bar along with the gasket.
- E. For orifice plates of size 2" to 6", insert the plate directly into the orifice plate carrier taking into account the flow direction of the system.
- F. For orifice plates of size 8" and above, rotate the plate carrier spindle to lift the plate carrier above the chamber and position the plate carrier stop to hold it in place for plate installation.
- G. Securely install the orifice plate into the plate carrier taking into account the flow direction of the fluid.
- H. Rotate the plate carrier spindle to lower the orifice plate carrier into the fitting body.
- I. Install a new sealing bar gasket, sealing bar, and clamping bar to secure the assembly.
- J. Tighten clamping bar screws.

The Tek-DP 1610A Single Chamber Orifice Fitting is now ready for operation in a fully pressurized line.

4 Operation

This section covers operation techniques and guidelines.



CAUTION

- The metering system might be under extreme high pressure. Carefully depressurize the line completely before attempting to remove the seal bar.
 - Carefully follow the instructions below to avoid accidental propulsion of fluid from the body.
 - Never place any part of your body over the meter body when the sealing bar gasket, sealing bar and clamping bar removed from the fitting.
-

The Tek-Dp 1610A Single Chamber Orifice Fitting enables accurate placement of an orifice plate in a pipeline in minimum shut-downtime.

The Tek-Dp 1610A Single Chamber Orifice Fitting is in normal operating mode when:

- The plate carrier and orifice plate are concentric to the flow pipeline
- The chamber is pressurized
- The clamping bar is tightly secured

A differential pressure transmitter is installed in the pressure taps to read the differential pressure generated across the orifice plate. Performance of the differential pressure transmitter depends on the orifice plate condition. Therefore, it is essential to inspect the orifice plate regularly for particulate deposition and general wear. Accurate plate replacement is critical for proper functioning of the orifice meter.

Follow the instructions below for safe and secured removal and replacement of the orifice plate every time.

4.1 Plate Removal

- A. Shut down the line supplying the process fluid to the Single Chamber Orifice Fitting.
- B. Depressurize the fitting to ambient pressure.
- C. Loosen the clamping bar screws; do not remove the clamping bar completely.
- D. Lightly tap the sealing bar to break the sealing bar gasket seal.
- E. Slide out the clamping bar from the fitting body.
- F. Lift out the sealing bar and the sealing bar gasket.
- G. Rotate the plate carrier spindle to raise the plate carrier.
- H. For orifice plates of size from 2" to 6", pull out the orifice plate from the plate carrier.
- I. For orifice plates of size 8" and above, rotate the plate carrier spindle to lift the plate carrier above the chamber and position the plate carrier stop to hold it in place for plate removal.
- J. Extract the orifice plate for inspection or replacement.

4.2 Plate Replacement

- A. Securely install the orifice plate into the plate carrier taking into account the flow direction of the fluid.
- B. Ensure that the orifice plate bevel faces downstream.
- C. Ensure that the o-ring seal or gasket is clean and install it in the plate carrier.
- D. Reinsert the plate carrier assembly into the fitting manually (for 2" to 6" sizes) or by rotating the plate carrier spindle (for 8" and above).
- K. Replace the sealing bar gasket, sealing bar and camping bar to secure the assembly.
- L. Tighten camping bar screws.
- E. Ensure that the meter taps, drain plugs are properly tighten.
- F. Slowly depressurize the line and ensure no leakage is encountered.

The Tek-DP 1610A Single Chamber Orifice Fitting is now ready for service in a fully pressurized line.

5 Maintenance

This section covers maintenance techniques and guidelines.

When using the Tek-DP 1610A Single Chamber Orifice Fitting, the product operator must perform a regular maintenance procedure scheduled by the product owner for prolonged service and measurement accuracy of the system. The recommended maintenance procedure is:

- A. Inspect the single chamber orifice fitting and the meter tubes by visually assessing the entire system for wreckage or damage.
- B. Tighten all the connectors and fasteners to avoid possible leakages.
- C. Inspect the piping, connectors, pressure taps, gaskets and bolts for erosion or corrosion, if any, due to process media. Replace the corroded parts to avoid future damage to the system.
- D. Apply a light coat of lubricant on the orifice seal ring for trouble-free installation and extraction of the plate carrier assembly.
- E. Lubricate the side valve, then open and close several times.
- F. Rotate the plate carrier spindle on regular interval even if plate replacement is not required.
- G. Perform a blow down operation to clear off the chamber of foreign materials, if any.



TEKMATION LLC reserves the right to change the designs and/or materials of its products without notice. The contents of this publication are the property of TEKMATON and cannot be reproduced by any other party without written permission. All rights reserved. Copyright © 2016 TEKMATON LLC
DOC#TEK/TPS/MNL/1610A/2405/0102
TEKMATION LLC



www.tek-trol.com

Tek-Trol is a fully owned subsidiary of TEKMATON LLC. We offer our customers a comprehensive range of products and solutions

for process, power and oil & gas industries. Tek-Trol provides process measurement and control products for Flow, Level, Temperature & Pressure Measurement, Control Valves & Analyzer systems. We are present in 15 locations globally and are known

for our knowledge, innovative solutions, reliable products and global presence.

Tek-Trol LLC

796 Tek Drive Crystal Lake, IL 60014 USA
Tel.: +1 847 857 6076 Fax: +1 847 655 6147
Email: tektrol@tek-trol.com
www.tek-trol.com

Flow | Level | Temperature | Pressure | Valves | Analyzers | Accessories | TekValSys