



Technology Solutions

TEK-DP1610B

Dual Chamber Orifice Fitting



FLOW

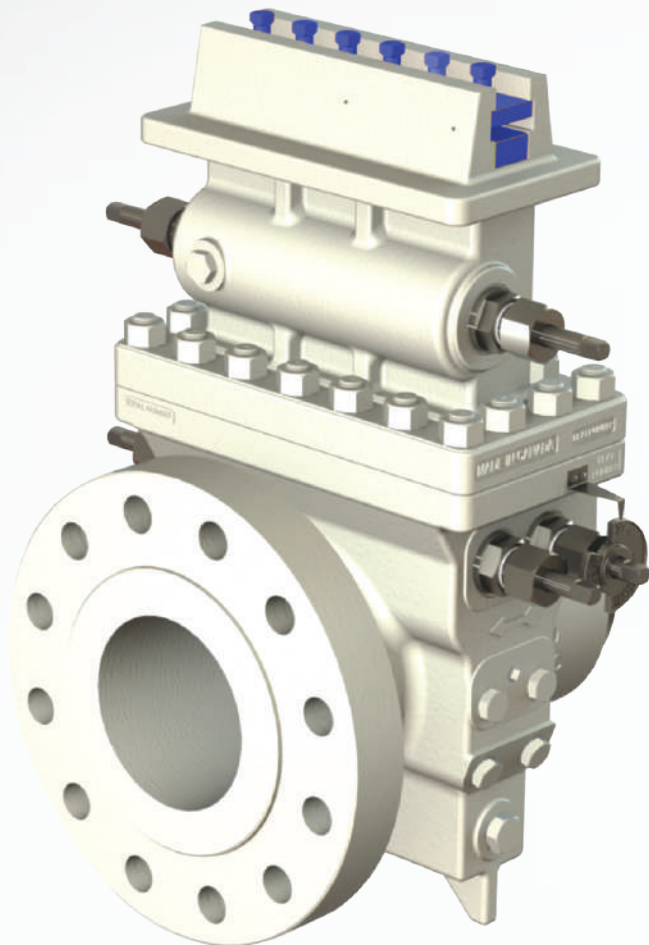

www.tek-trol.com

Flow | Level | Temperature | Pressure | Valves | Analyzers | Accessories | TekValSys

*Combining safety with convenience
Measurement made easy*

Features

Easy plate removal and replacement

- No need to shut down pipeline

High-pressure solution for up to ANSI 2500 rating

- Rated to 10,000 psi (698 bar)

Maintenance can be performed at any time

- No need to wait for annual shutdown

Economical orifice installation

- Plate serviceable without removing fitting from pipeline

Pressures up to ANSI 2500 rating

- For pipe sizes up to 12" (1ft.)

Comprehensive testing and documentation package

- Supplied as standard

Introduction

Tek-Trol's Dual Chamber Orifice is a proven system for safely and quickly inspecting and changing orifice plates.

The Tek-DP 1610B is a high-quality fitting that is a pivotal component in an orifice measurement system. These dual-chamber orifice fittings are built to meet or exceed ASME and ANSI standards as well as ISO-5167, AGA-3/API-14.3. This is ideal for the Oil and Gas industry as well as any industry where accurate flow measurement is required.

Dual chamber orifice fittings such as the Tek-DP 1610B have an extra chamber into which the orifice plate is first withdrawn; this chamber has a single isolation from the pipeline. This means that the flow in the pipeline does not have to be stopped to enable removal and refitting of the orifice plate and, although the second chamber must be vented, there is no requirement to vent the pipeline section.

Each fitting has been designed and optimized utilizing FEA (Finite Element Analysis). The fittings are also pressurized to 150 % of the specified working pressure.

The Tek-DP 1610B is designed and manufactured in compliance with ASME 16.34 and ASME 16.5, ASTM specifications, AGA-3 Latest Edition and ISO-5167.

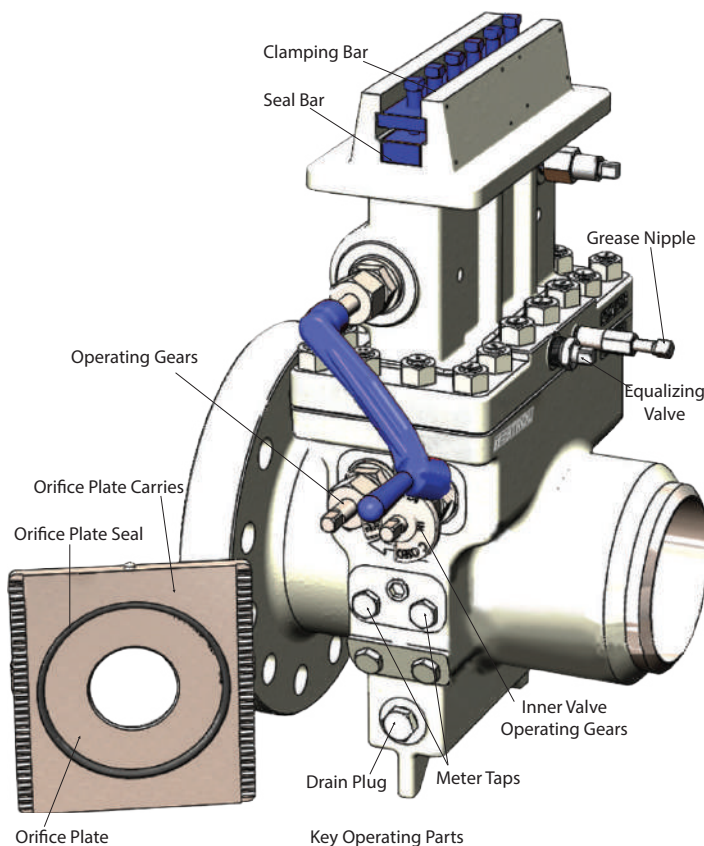

Measuring Principle

The Tek-DP 1610B Smart Orifice Meters work on the principle of differential pressure measurement. Based on Bernoulli's theory of conservation of mass and energy in a closed pipe, the obstruction to the flow of fluid leads to an increase in the flow velocity (i.e. $V_2 > V_1$), thereby creating a pressure drop. The fluid flow rate depends on the static pressures at upstream and downstream, minimum cross sectional area and temperature. It is calculated by applying the law of conservation of mass and energy.

The relation between the differential pressure and flow rate is represented as the below expression-

$$\Delta p \propto Q^2$$

The differential pressure generated, Δp , is proportional to the square of mass flow rate, Q . In simple terms, for a given size of restriction, higher the differential pressure, Δp , higher is the flow rate, Q .

1610B Dual Chamber Orifice Fitting

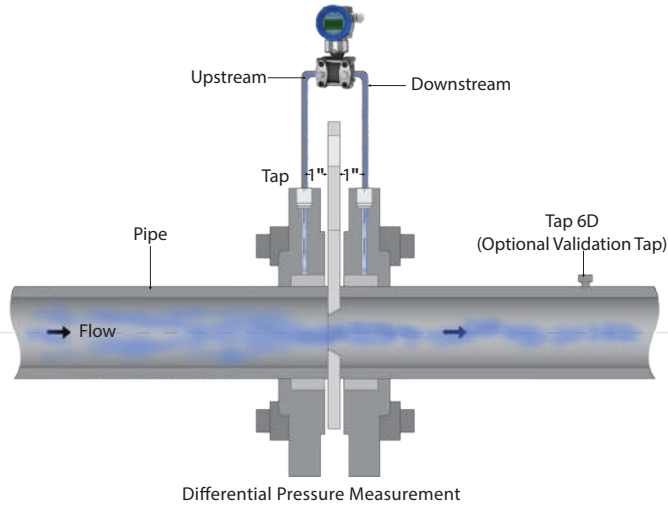

Operation

The complete orifice meter assembly is comprised of an orifice plate that is positioned between the two flanges with the help of an orifice plate carrier and other essential components such as the flow conditioner, pressure taps, and the transmitter. The orifice plate acts as a restriction to the flow of the fluid.

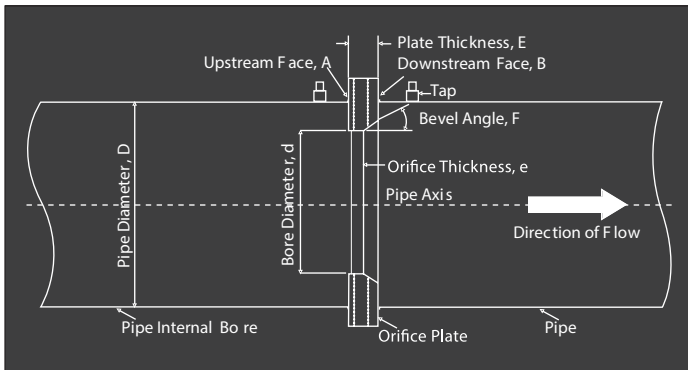

Operation of an Orifice Flow Meter

The fluid in motion passes through an abrupt obstruction created by the orifice plate. This results in a sudden pressure drop, which varies with the flow rate. As the fluid converges to pass through the bore, its velocity increases. The flow continues to converge at the downstream of the plate until it reaches the vena contracta point (the point of maximum convergence) and then expands to rejoin the pipe wall. The pressure taps measure static pressures of the upstream and downstream flow. The differential pressure is proportionate to the flow rate and can be determined by the equations defined in defined in AGA 3 and ISO 5167 standards.

The Tek-DP 1610B Dual Chamber Orifice Fittings are highly reliable dual chamber devices constructed for flow measurement in oils, gases and liquids. The field-proven dual chamber technology ensures extremely simple, fast and safe method of changing orifice plates under pressure without flow interruption. These orifice fittings are pivotal in the processes where a shutdown time is impractical.

Tek-trol's Dual Chamber Orifice Fittings strictly comply with the latest AGA 3/API 14.3 concentricity requirements. Its three-point plate centering mechanism ensures accurate and repeatable plate positioning with minimum eccentricity. The first chamber of the dual chamber orifice fittings holds the orifice plate securely in the flow line, whereas the second chamber provides room to withdraw the orifice plate for inspection. With the help of a spindle, the operator can easily move the orifice plate from the first chamber to the second chamber without interrupting the pressurized line.

Tek-Trol's precisely designed soft seat valve seals provide a bubble-tight seal between the upper and lower chambers and eliminate the need of frequent lubrication. The soft seals eliminate the need for expensive piping by passes or additional valves and fittings required in case of conventional orifice flange installations.

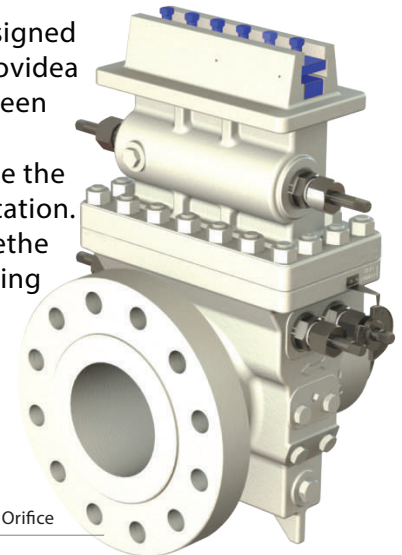

Dual Chamber Orifice

Tek-Trol's Dual Chamber Orifice Fittings undergo a quality check for pressure tap integrity, positive plate seal, seal protrusion and eccentricity. The Tek-DP 1610B Dual Chamber Orifice Fittings are available in a wide selection of sizes from 2" to 48" and materials to fulfill most flow application needs. Special corrosion resistant and other optional casting materials are available for corrosive fluids and other challenging conditions. The Tek-DP 1610B Dual Chamber Orifice Fittings are well-known for their high accuracy and superior performance in globally competitive costs.

Features

- Highly reliable and field-repairable
- Ensures fast and safe plate replacement
- Requires no breaking apart or depressurized the flow line
- No operational downtime
- Eliminates liquid or gas leakage possibility
- Offers versatility of line sizes

Applications

- Oil and gas custody transfers
- Water, wastewater treatment plants
- Shale liquid production
- Chemically active and corrosive liquid transfers

Technical Specifications

Body Configuration

Flange x Flange, Flange x Weld, Weld x Weld
Flanges to FF, RF, and RTJ are available in the following format: ANSI 16.5 or 16.47, Techlok and SPO, Grayloc, API 6A or to specific client specification

Measurement Standards

ISO 5167, API MPMS14.3.2 (AGA-3)

Internal Components

Stainless steel 316/316L, Stainless steel A351 CF8M, Carbon steel AISI430

Temperature Rating

As ratings of material and flanges fitted

Design Codes

ASME B31.8 Gas Transmission And Distribution Piping
NACE Mr-01-75
ASME B31.1 Power Piping
ASME B31.3 Liquid Petroleum Transportation Piping Systems PED 97/23/EC – Pressure Equipment Directive

Standard Materials

Body casting: ASTM A216 WCB, WCC ASTM A352 LCC
ASTM A351 CF8M
ASTM A995 Gr.4a, Gr.6a
Other materials are available on request

Flanged Pressure Taps

Pressure tap ID for 2" & 3" fitting : 3/8" ID while for 4" and larger fittings: 1/2". Tolerance $\pm 1/64$ ". Two pairs 1/2" NPT standard with additional one/two pair TT taps as optional. Tap hole center location : @u/s end 1" from upstream face of plate and @d/s end 1" from ASTM A194 downstream end of plate. 4 (Zinc coated), ASTM A320 L7 (Zinc coated) downstream end of plate

External Bolting

Other materials are available on request, including optional coatings such as PTFE, Xylan and Xylar

Seals

Seal bar: HNBR O-ring (standard), gasket (optional)
Shafts: PTFE packing (standard), HNBR O-ring (optional)
Inner valves Grease seal (standard);
HNBR O-ring (optional) Orifice plate

Type 'K' 2000 edition formed HNBR seal on a 316 SS retainer ring. Dual ring HNBR O-rings standard on A 316 SS retainer ring PTFE snap seal two-piece virgin PTFE assembly

Orifice Plates

Industry-standard orifice plate thicknesses as per the guidelines set out within ISO 5167 and API 14.3.

Maximizing Performance

To ensure absolute metering accuracy, it is recommended that industry practice is followed and meter tubes are purchased and manufactured to complement the orifice fitting. This ensures egocentricity between the pipe and the fitting and eliminates uncertainties associated with misalignment.

Pressure Rating

Size: 2" to 12" (0.16 ft to 1 ft)
ANSI pressure class: 150, 300, 600, 900, 1500
Size: 14" to 24" (1.16 ft to 2 ft)
ANSI pressure class: 150, 300, 600, 900, 1500

Double Block and Bleed (DBB)

The Double Block and Bleed (DBB) option when selected enables the dual isolation feature to ensure safe removal of the orifice plate while the line remains pressurized and the product continues to flow and complies with the HSG253 publication for the *safe isolation of plant and equipment*. The DBB option uses two independent chamber seals to ensure maximum safety during live orifice plate changes or routine inspections. Valve isolation is provided by using a double block and bleed arrangement and independent pressure gauges are integrated into the chambers to provide a visual display of the pressures in each chamber, enabling operators to see whether the process is properly isolated.

Dimensional Drawing

Dual Chamber Fitting

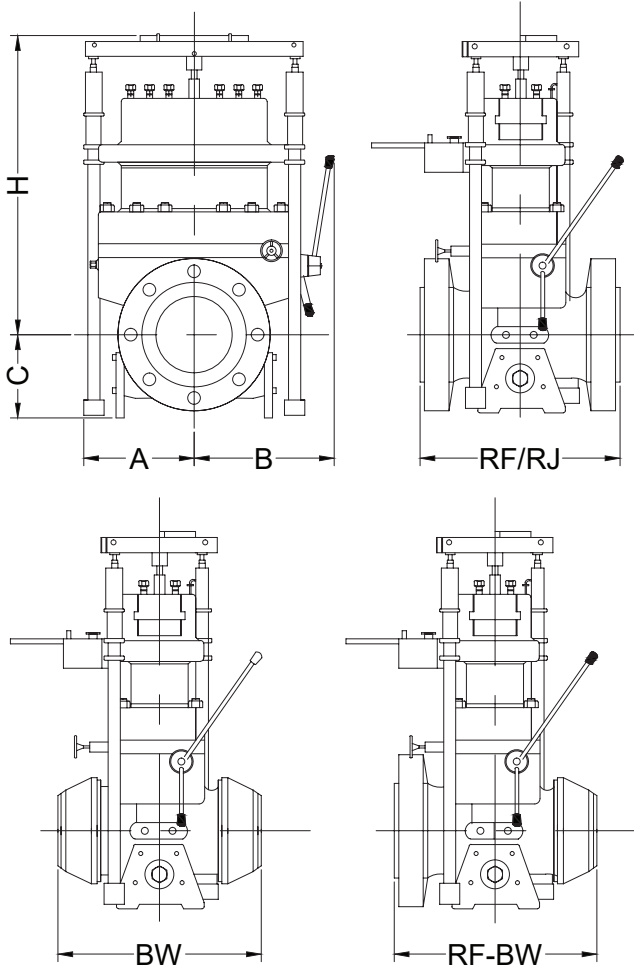

AGA 3 Report

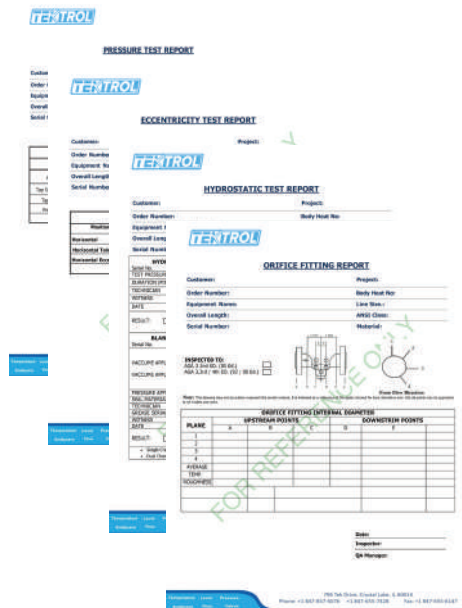

Tek-Trol can supply the following items for a complete metering solution:

- Orifice fitting with meter tube including straightening vane/profiler
- DP transmitters and process transmitters
- Flow computers and enclosure
- Spare parts for service and commissioning
- Product service training

Installation Guidelines

- Install the orifice meter between the upstream and downstream meter run sections. Place the fitting in line with the two flange taps, positioning the instruction plate facing upward.
- It is possible to install the fitting in either horizontal or vertical position. Ensure that the flow arrow on the outer surface of the fitting corresponds to the direction of flow in the pipeline.
- Use of vertical mount is recommended for wet gas measurement to prevent moisture formation against the orifice plate.
- Ensure that the lower cavity of the fitting is free of dust and debris, before inserting the orifice plate into the fitting.

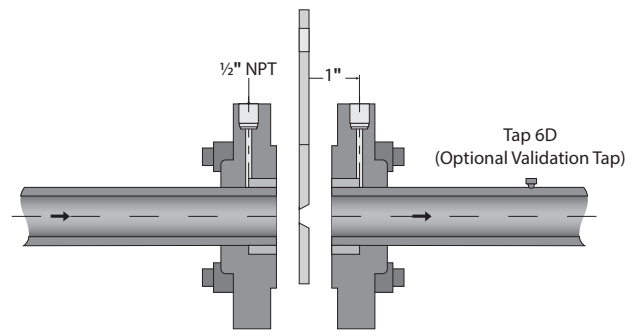

The location, size and construction of the orifice meter pipe taps can affect the meter's accuracy. Tek-Trol Orifice Fittings are supplied are offered with two 1/2" NPT taps per side are standard, two additional 1/2" NPT taps can be provided as optional to connect additional field devices.

Taps sizes for 2" and 3" fitting are 0.375" inside diameter and for 4" and larger sizes these taps are center bored to .500" inside diameter. Fittings are manufactured with Tap located 1" from the face of the orifice plate with accuracy/ tolerance in line with AGA 3 requirements .

Orifice Plates and Seals

Tek-Trol's Orifice Plates and Seals play a key role in maintaining the performance and durability of orifice flow meters. Tek-Trol's all orifice plates comply with AGA-3/API 14.3 or ISO 5167-1 standards to ensure maximum accuracy. The orifice plates are responsible to create a restriction in the fluid flow path for generating a differential pressure, which is measured across the plate through two taps located on the Single Chamber Orifice Fitting near the constriction. Types of orifice plates include conical, quadrant-edge, and square-edged entrant concentric, eccentric, and segmental orifice plates.

Tek-Trol's orifice plates and seals are compatible with all orifice fitting variants- Single Chamber, Dual Chamber and Orifice Flange Unions. The seals, crucial to maintain the leak-proof connections, are available in all plate sizes and types (soft seat valve seals, O-ring seals). All universal orifice plates are manufactured within the strict tolerances as specified in AGA3 latest edition along with AGA3 compliant Orifice Inspection Plate reports.



Universal Type Orifice Plate

The Universal Type Series provides orifice plates without a handle, which are manufactured for use in orifice plate holders in case of Single Chamber and Dual Chamber Orifice Fittings. Tek-Trol's fail-safe concentric design of universal type orifice plates eliminates the possibility of improper plate orientation and positioning. Tek-Trol supplies orifice plates in standard 304SS and 316SS corrosion-resistant material in a range of plate sizes from 1" to 48" to fulfil application needs. The orifice plates are also available in custom materials such as Duplex, Super Duplex, Monel, Inconel, and Hastelloy. The seals, crucial to maintain the leak-proof connections, are available in all plate sizes and types (soft seat valve seals, O-ring seals).

Features

- Robust design, Easy to install & Cost effective
- Proven leak-proof connection when used with seals
- Available in all sizes and materials
- Separable seals for 8" and below sizes
- Special DVS bonded seals for 10" and above sizes

Technical Specifications

Size

1" to 48", Larger line size available on customer request

Material

SS304L, SS316L, Duplex, Super Duplex, Monel, Inconel, and Hastelloy (Other material available on application)

Bore

Concentric, Eccentric, Quadrant

Surface Finish

Better than 25micro inches as per AGA3

Universal Orifice Plates

Line Size (In)	Plate O.D.	Plate Thickness (In)
¾	1.125	⅛
1	1.312	⅛
1½	2	⅛
2	2.437	⅛
2½	2.812	⅛
3	3.437	⅛
4	4.406	⅛
6	6.437	⅛
8	8.437	¼
10	10.687	¼
12	12.593	¼
14	14	¼
16	16	⅜
18	18	⅜
20	20	⅜
24	24	½
26	26	½
30	30	½

Bonded Plates

Line Size (In)	Plate O.D.	Plate Thickness (In)
12	12.079	¼
14	14.563	¼
16	16.563	⅜
18	18.563	⅜
20	20.563	⅜
24	24.500	½
26	26.750	½
30	30.750	½
34	35.228	½
26	38	½
42	44	¾



Meter Runs

Tek-Trol's standard and custom fabricated meter runs are compatible with all orifice fitting models to meet specific performance needs of challenging metering applications. These meter runs adhere to the highest quality specifications set by AGA-3/API 14.3 and ISO 5167-1 to ensure adequate length, precise alignment, and smooth finish for enhanced measurement reliability.

Tek-Trol's meter-runs are manufactured to meet the appropriate upstream/downstream straight pipe length, surface requirements, roundness, and flow tolerance. As manufactured in a single unit, these pre-assembled meter runs allow rapid installation and reduce start up costs. These rigorously tested and inspected meter-runs are exceptionally accurate, extremely reliable, and ready for service.

Tek-Trol's two section meter runs are compatible with all styles of orifice fittings and plate holders. These accurate, dependable instruments have a section of meter tube on either sides of the orifice fitting. Each tube adheres to an upstream and downstream of the minimum length prescribed by API 14.3. Longer upstream meter tube provides adequate length for stabilizing the flow before it passes through the orifice plate.

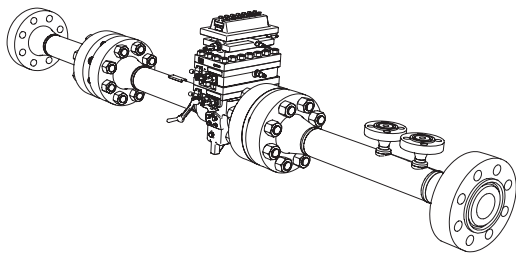

Tek-Trol's three section meter runs incorporate an additional component, a flow conditioner, which helps reducing the overall upstream meter tube length. The flow conditioner plate inserted on the upstream effectively minimizes swirls and turbulence to ensure steady flow profile. These meter runs are utilized in highly turbulent flow and congested places where maintaining the standard upstream length is impossible.

Tek-Trol can provide custom meter run packages that meet specific application needs like pipe size from 1" to 48", pipe materials such as A216 WCB, A216 WCC, A352 LCC, and operating pressure from 150 ANSI to 2500 ANSI.

Material Selection

Tek-trol uses special cold drawn seamless tubing or honed pipe in the fabrication of meter tubes. The strict requirements for internal roundness and surface finish preclude the use of standard commercial pipe in most cases. Daniel maintains a large inventory of this special pipe to rapidly complete your order.

Fabrication

Fabrication of your instrument includes attaching the orifice fitting to the meter tube to make an integral primary measuring element. For welding operations, Daniel uses automatic welding machines and rotating positioners. Highly skilled, "code qualified" welders are employed to turn out highest quality on each job. Special internal jigs and fixtures are used to insure smooth inlet and outlet surfaces without steps or offsets. All welds receive expert grinding by experienced craftsmen.

Inspection/Testing

Tek-Trol maintains rigid inspection procedures during manufacturing of meter tubes. Micrometer and internal surface roughness readings recorded and supplied with each meter tube. Customer or third party inspectors are welcome to verify these readings. Radiography of welds is another service that is available.

Meter Tube Tolerances

The I.D. for the upstream should be within $\pm 0.25\%$ within the initial diameter from the plate. The rest of the upstream should be within $.5\%$ with the result being a maximum difference of $.5\%$ between any 2 diameters. The tolerances of downstream can be 1% of upstream. I.D. roughness varies with size and beta ratio. Designing of meter tubes should be for the maximum allowable beta ration. All Tek-trol standard meter tubes are manufactured to meet tolerances recommended by API. Chapter 14, Section 3, Part 2 (14.3) April 2000/AGA. #3. The tubing and pipes allocated for meter tubes should have a uniformed internal surface that is smooth and meets the standard diameter/roundness tolerances.

Features

- Ensure optimum compatibility with all products
- Eliminates the measurement inaccuracies recorded in small orifice line installations
- Inserts sufficient pipe length to reduce distortions due to pipe roughness
- Eliminates the possibility of plate misalignment
- Avoids possible leak points



Technical Specifications

Body Materials

A216 WCB, A216 WCC, A352 LCC, A358 CF8M, A995 Gr4A, A995 Gr6A, Custom material available on request

Internal Parts

AISI 4130 Carbon Steel, 316 or A351 Stainless Steel

Pipe Sizes

1" to 48", Custom size available on request

Operating Pressure

150# to 2500# ANSI

Operating Temperature

Standard at -20 °F to 100 °F (-28 °C to 37 °C),
Optional -40 °F to 1200 °F (-40 °C to 648 °C)

Orientation

Vertical or horizontal

Process Products

Liquids and Gases

Meter Tube Surface Roughness

For meter runs with nominal diameters of 12" or smaller:

- The maximum meter-tube roundness shall not exceed 300 micro inches Ra if the diameter ratios are equal to or less than 0.6.
- The maximum meter-tube roundness shall not exceed 250" Ra if the diameter ratios are equal to or less than 0.6.
- The maximum roundness shall not be less than 34" for all diameter ratios.

For meter runs with nominal diameters larger 12":

- The maximum meter-tube roundness shall not exceed 600 micro inches Ra if the diameter ratios are equal to or less than 0.6.
- The maximum meter-tube roundness shall not exceed 500 micro inches Ra if the diameter ratios are equal to or less than 0.6.
- The maximum roundness shall not be less than 34" for all diameter ratios.

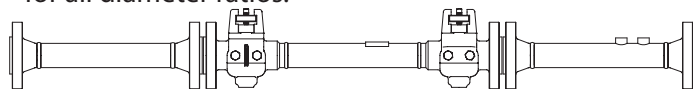

Features

- Ensure optimum compatibility with all products
- Eliminates the measurement inaccuracies recorded in small orifice line installations
- Inserts sufficient pipe length to reduce distortions due to pipe roughness
- Eliminates the possibility of plate misalignment
- Avoids possible leak points

Technical Specifications

Design Code

ISO-5167, API 14.3 (AGA-3)

Configuration

2 Pc or 3 Pc design

Surface Finish

- For meter runs with nominal diameters of 12" or smaller: 250 micro inches with a minimum roughness of not be less than 34 micro inches
- For meter runs with nominal diameters larger than 12": 500 micro inches or better with minimum roughness not less than 34 micro inches for all Beta ratio.

Line Size

2" to 48" (Larger line size available on application)

Pressure

150# to 2500# (Higher pressure available on application)

Pipe Material

Carbon Steel, Stainless Steel, Duplex, Low Temp Steel and other material available

Studs, Nuts

Carbon steel, Stainless with/without Teflon/ Hot Dip Galvanized options.

AGA 3 Report

TEKTROL
INSPECTION REPORT FOR AGA METER TUBE

Customer: _____ Project: _____
 Order Number: _____ Body Heat No: _____
 Equipment Name: Single Chamber Orifice Fittings Line Size: _____
 Overall Length: _____ ANSI Class: _____
 Social Number: _____ Material: _____

METER TUBE LENGTH Overall Length: _____ U.S. Length: _____ U.S. Length: _____ Flute To Orifice / Area: _____ Flute to First O.D. DIM: _____

ROUNDNESS CHECK
 Dia From Flute Injection Steel = _____ Largest Number within 20' Diameter of Orifice Hole (MUST BE SMALLER THAN 10)
 O.D. & Dia = _____ Smallest Number within 20' Diameter of Orifice Hole (MUST BE BIGGER THAN 10)
 I.D. & Dia = _____ Largest Secondary Measurement (Outside Flute)
 Dia = U = _____ Smallest Upstream Measurement (Outside Flute)
 Dia = V = _____ Largest Downstream Measurement (MUST BE SMALLER THAN V)
 Dia = W = _____ Smallest Downstream Measurement (MUST BE BIGGER THAN W)

PLANE	UPSTREAM POINTS						DOWNSTREAM POINTS					
	U1	U2	U3	U4	U5	U6	D1	D2	D3	D4	D5	D6
1												
2												
3												
4												
AVERAGE												
TOP												
ROUNDNESS												

Date: _____
 Inspector: _____
 QA Manager: _____

TEKTROL
 796 Tok Drive, Crystal Lake, IL 60014
 Phone: +1 847-857-8876 +1 847-855-7628 Fax: +1 847-855-8347

Flow Conditioners

Tek-Trol's Flow Conditioner Range is meticulously manufactured for converting an irregular upstream flow to a predictable downstream flow. These flow conditioners are available from 2" to 48" pipe sizes and in a variety of materials such as duplex, 304SS and 316SS, making these suitable for all applications including extremely corrosive environments. Properly selected and installed flow conditioners eliminate swirls and turbulence; making the flow profile much more reliable. The complete flow conditioner range is suitable and essential for any fluid measurement scenario including water, crude oil, petroleum, air, light hydrocarbons and natural gas for providing stable downstream flow. This design fully develops the flow profile and significantly reduces upstream pipe length requirements.

Tek-Trol offers flange type, inserting type and ring type of flow conditioners in compliance with AGA3/API 14.3 standards to adapt with various configurations.

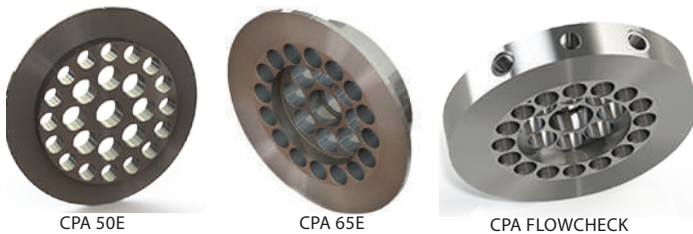

Features

- Easy to install, field repairable
- Cost effective
- Minimize swirls and turbulence
- Eliminate effects of flow disturbance
- Reduces upstream meter run length
- Suitable in all liquid and gas applications with no upper limit on Reynolds number

Technical Specifications

Line Size

2" to 48", Larger size available on request

Process Media

Natural gas, air, crude oil, water, light hydrocarbons

Performance

In accordance with AGA3/API 14.3, ISO 5167

Maximum Pressure

ANSI 1500

Body Material

Stainless Steel (304, 316 and duplex), Optional materials available

Straightening Vanes

Tek-Trol's straightening vanes are designed to be installed in the upstream orifice meter runs to serve dual purpose: (1) They convert complex, turbulent flow into a smoothed, reliable flow pattern and (2) They reduce upstream pipe length requirements.

Tek-Trol's straightening vanes are available in standard corrosion resistant materials including 304, 316 stainless steel and carbon steel making them suitable for wide types of gas and fluid applications. These straightening vanes are manufactured in both line-mounted and flanged models, in strict compliance with API 14.3 and ISO 5167 standards. The line-mounted model is inserted in upstream pipe and secured with the help of screws. The flanged type model is flanged between upstream line flanges.

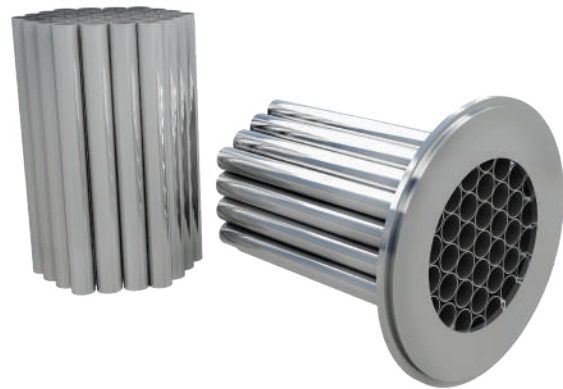

Straightening Vanes

Features

- Reduce swirls and turbulence
- Condition upstream flow profile
- Reduce upstream meter run length
- Enhance measurement accuracy

Technical Specifications

Line Size

2" to 48", Larger size available on request

Process Media

Natural gas, air, crude oil, water, light hydrocarbons

Performance

In accordance with AGA3/API 14.3, ISO 5167

Maximum Pressure

ANSI 1500

Body Material

Stainless Steel (304, 316 and duplex), Optional materials available

TekValSys-DP

Tek-Trol's extremely powerful flow validation tool, TekValSys-DP, based on Prognosis, converts a mechanical DP flow measurement device into a smart, comprehensive flow measurement solution. The TekValSys-DP can be utilized in many DP Metering applications including single-phase gases, liquids, steams, heavy oils, and water-in-oil mixtures. The TekValSys-DP can be used with any device creating differential pressure such as orifice, cone, pitot tube, venturi or flow nozzles. The system requires two additional differential pressure measurements in addition to the traditional DP transmitter.

The TekValSys-DP software available in three versions, namely, micro, light and pro, can be easily integrated into an existing DP control system. Once installed, the TekValSys-DP system provides real-time alerts of meter measurement and performance shifts, making easy monitoring and reducing maintenance overhead.

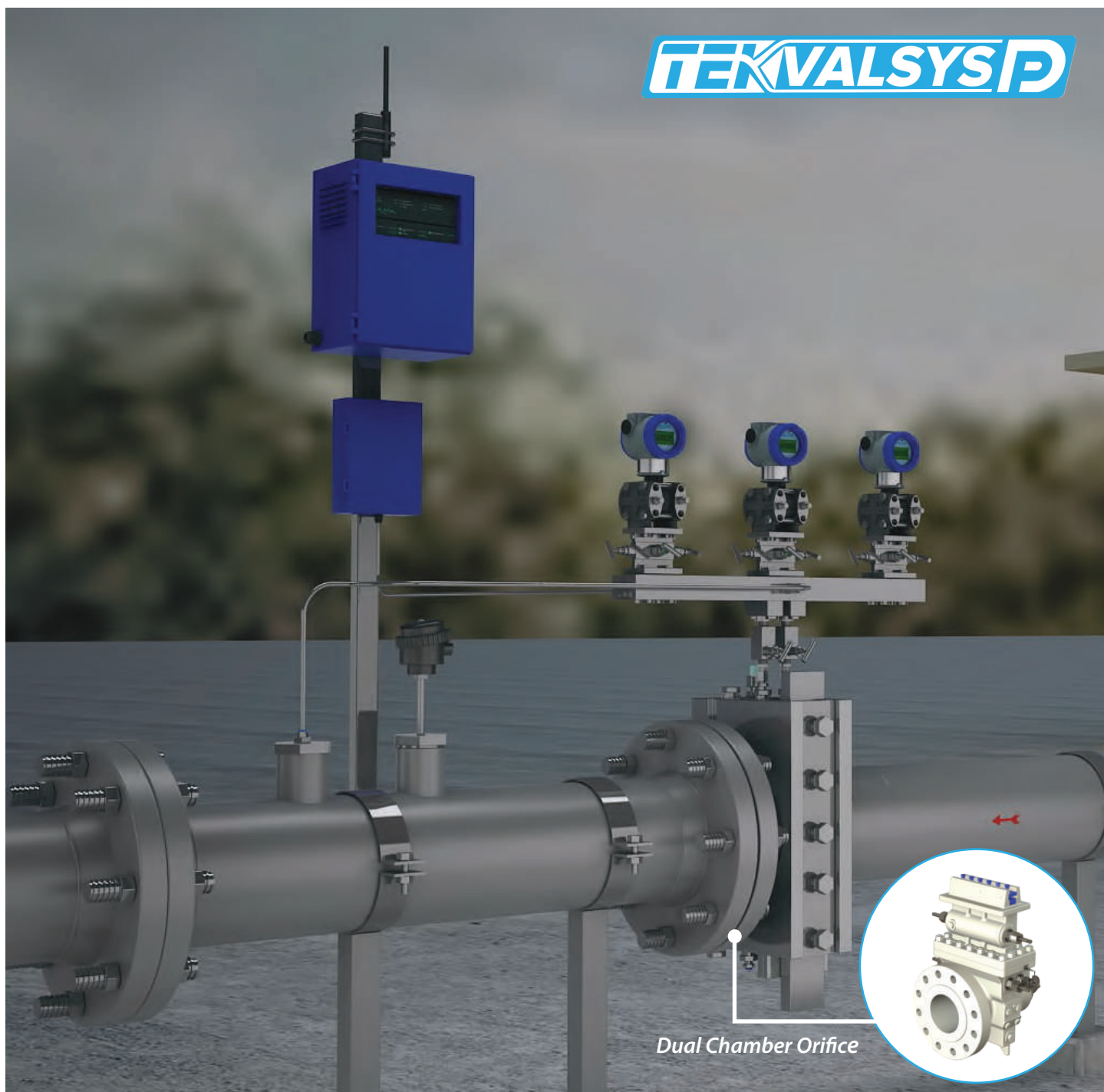

Features

World-class configuration, service, and troubleshooting tool

- Supports all differential pressure flowmeters
- Supports all smart pressure differential transmitters
- Management and simulation of captured data points

Intuitive display of process variables and diagnostics

- Enhanced data logging functionality, both on demand or time-based
- Graphical process variable trending views

Support for multiple devices

- Simultaneously connect to multiple primary and secondary devices
- Ideal tool for evaluating multiple devices simultaneously

Benefits

Reduced Financial Exposure to Measurements

- Real time alerts of non-compliance and significant measurement bias
- Avoid measurement disputes and damaged reputation
- Distinguish error or drift in DP transmitter readings from meter system issues

Reduced Maintenance Costs

- Condition-based monitoring allows condition-based maintenance
- Reduced Maintenance regime due to condition-based responses

Reduced Risk to Personal Health and Safety

- Avoid requirement to break hydrocarbon containment
- Avoid maintenance induced errors or incidents
- Reduce trips to remote and hazardous location
- Improve H & S Record

Assurance of Meter System Performance

- Improved assurance of metering system accuracy
- Definitive confidence in meter result
- Real time and historical proof of meter performance

Financial Playback could be Achieved in Matter of Days

- TekValSys DP will distinguish between a secondary instrumentation issue and a primary meter body-based physical problem avoiding unnecessary inspection and down time

Applications

The benefits of prognosis can be realized an many DP metering applications including the following:

- Single phase gas single phase liquid
- Heavy oil- TekValSys DP will identify viscosity if it is not known accurately
- Steam- TekValSys DP will indicate whether the steam is saturated or superheated
- Steam- TekValSys DP will monitor shifts in level,of saturation and indicate direction of shift from initial saturation point
- Wet Gas- Once liquid loading is identified , TekValSys DP will monitor for shifts and indicate direction of shift in liquid

<p>TekValSys DPro Trust PC</p>	
<p>TekValSys DPro Micro</p>	
<p>TekValSys DPro Cloud</p>	
<p>TekValSys DPro ROC Platform</p>	
<p>TekValSys DPro FCA</p>	
<p>TekValSys DPro integration with FloBoss / Omni</p>	

Customer Service and Support



TEK-TROL LLC reserves the right to change the designs and/or materials of its products without notice. The contents of this publication are the property of TEK-TROL and cannot be reproduced by any other party without written permission. All rights reserved. Copyright © 2016 TEK-TROL LLC
TEK-TROL LLC
DOC # TEK/ITPS/CAT/240520/16108/01.2



www.tek-trol.com

Tek-Trol is a fully owned subsidiary of TEKMATIION LLC. We offer our customers a comprehensive range of products and solutions for process, power, and oil and gas industries. Tek-Trol provides process measurement and control products for Flow, Level, Temperature and Pressure Measurement, Control Valves, and Analyzer systems. We are present in 15 locations globally and are known for our knowledge, innovative solutions, reliable products, and global presence.

Tek-Trol LLC

796 Tek Drive Crystal Lake, IL 60014 USA
Tel: +1 847 857 6076 Fax: +1 847 655 6147
Email: tektrol@tek-trol.com
www.tek-trol.com