



Technology Solutions

# TEK-DP 1610C

## Orifice Flanges and Plates



FLOW

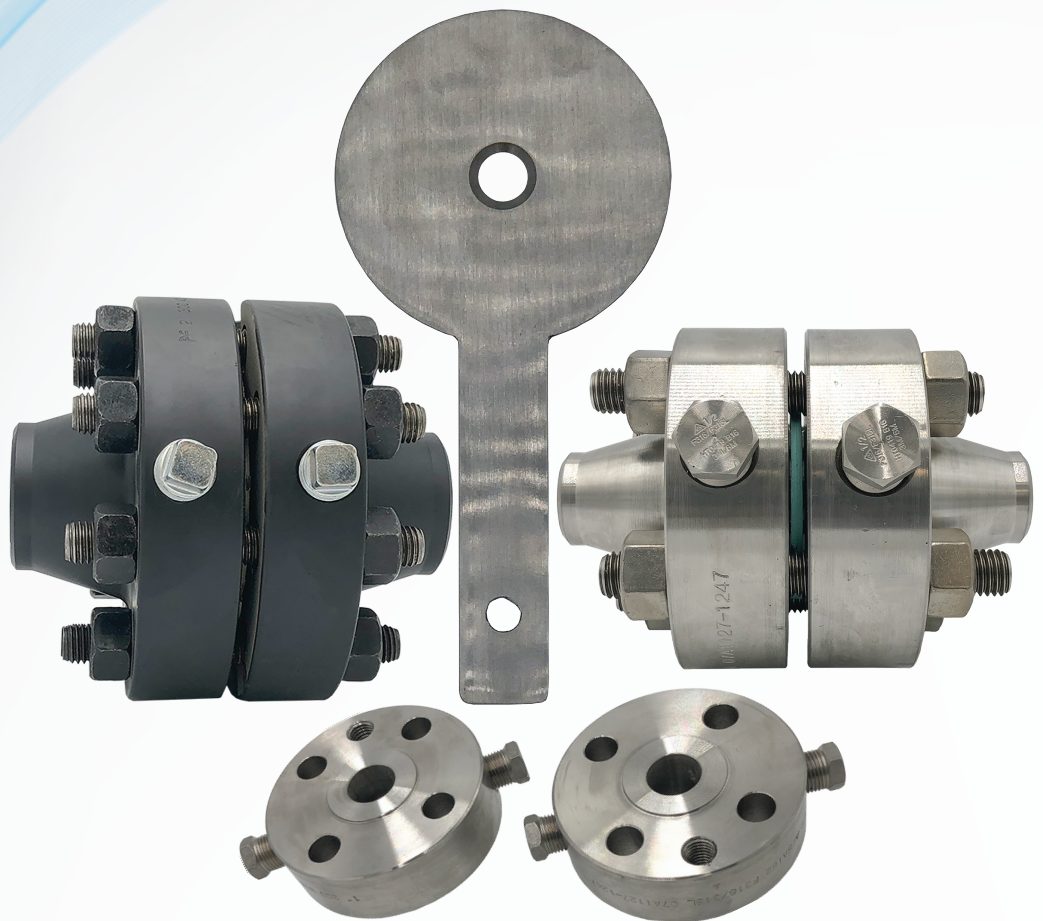

## Introduction

Orifice flanges are essential in orifice metering equipment for holding the pipelines together. Flanges are used in conjunction with orifice meters and accommodate an orifice plate holder for placing the orifice plate. Additional bolts and screws facilitate sturdy flange connections and allow easy dismantling of flanges for plate inspection and replacement.

Tek-DP 1610C series includes weld neck, slip-on and threaded flange types to match your requirement. These flange classes are manufactured in flat face, raised face and ring joint types.

An orifice plate is the backbone of orifice meter. It's a metal plate with a hole in it and is placed in the flow pipeline. It is responsible to create restriction in the flow, which is used for measuring fluid flow rate. Tek-DP 1610C series includes the variants of concentric, eccentric, and segmental orifice plates with conical, quadrant-edge, and square-edged entrance.

## Measuring Principle

Orifice meter works on the principle of differential pressure measurement. It is based on Bernoulli's theory of conservation of mass and energy in a closed pipe. According to this principle, the obstruction to the flow of fluid leads to increase in flow velocity (i.e.  $V_2 > V_1$ ), thereby creating a pressure drop. The flow rate can be determined by measuring the static pressures at upstream and downstream, minimum cross sectional area and temperature. The flow rate of the fluid is calculated by applying the law of conservation of mass and energy.

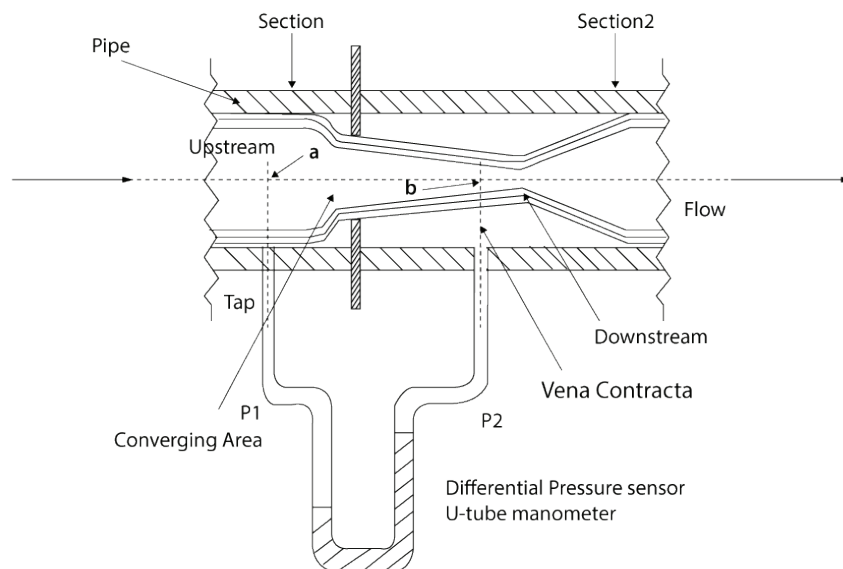

Bernoulli described this relation between differential pressure and flow rate by equation,

$$\Delta p \propto Q_m^2$$

The differential pressure generated,  $\Delta p$ , is proportional to the square of mass flow rate,  $Q_m$ . In simple terms, for a given size of restriction, higher the  $\Delta p$ , higher is the flow rate.

## Tek-DP 1610C series Orifice Flange Types

The complete flange assembly consists of two pressure tap holes (extending radially outwards), orifice plate holders, and jack screws.

Types of flanges depending on finish of flange connections:

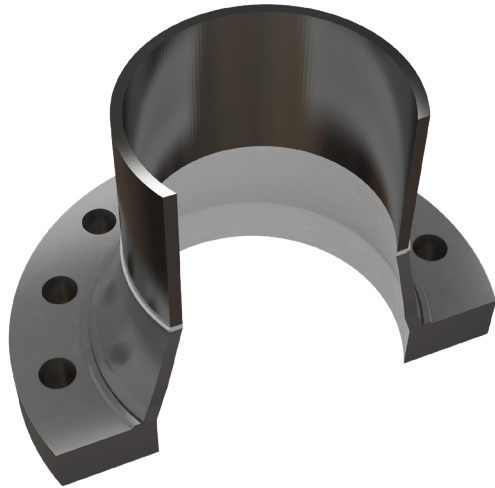

- **Weld Neck Pipe Flanges**

These flanges are attached by welding the pipe to the flange neck. This design transfers stress from the flange to the pipe. Weld neck flanges are suitable in high-pressure applications where welding flanges make the connection strong enough to withstand extreme pressure conditions. The inner diameter of the flange matches the inner diameter of the pipe making a leak-proof connection.

- **Slip-On Pipe Flanges**

Slip-on type orifice flanges slide over the pipe. The inner diameter of the flange is designed slightly higher than the outer diameter of the pipe for easy accommodation.

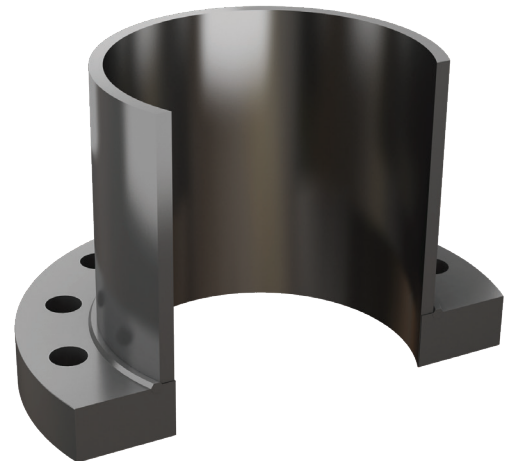

- **Threaded Pipe Flanges**

The bore of threaded pipe flanges has tapered threads on its inner rim to screw it with the pipe. The pipe, on the other hand, has external threads. The threaded flanges orifices do not require welding. These are typically used in small diameter, high-pressure applications.

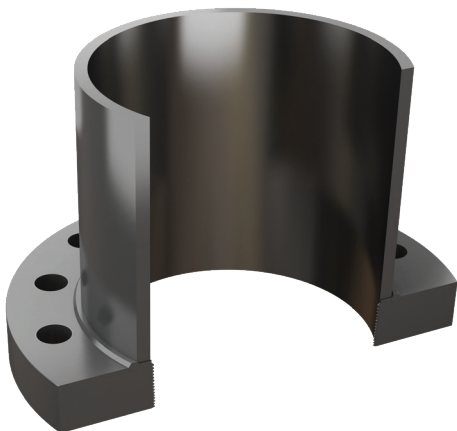

## Types of flanges depending on finish of contact faces

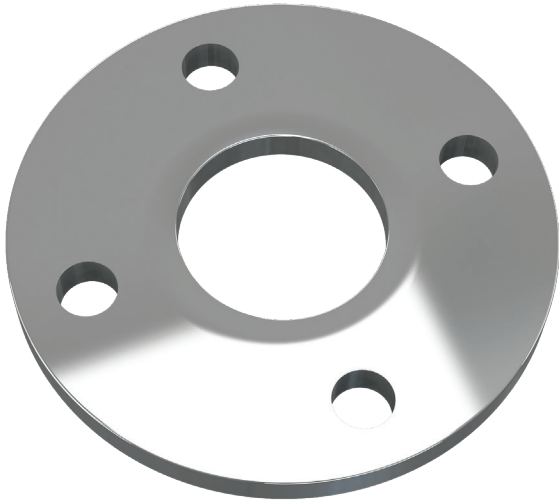

- *Flat face flanges*

These flanges have flat contact surfaces at the same height of the bolting line of flange. It is the simplest type of flange facing.

- *Raised face flanges*

In raised face flanges, the gasket surface is located above the bolting line of the flange. The height of the raised surface may vary according to the flange pound rating.



- *Ring type joint flanges*

These are the most efficient flanges in pipeline design. Ring joint flanges have a deep groove in a ring around the face. While bolting the faces, a metal ring is compressed in this groove, which ensures extremely tight, leak-proof seal on the connection.

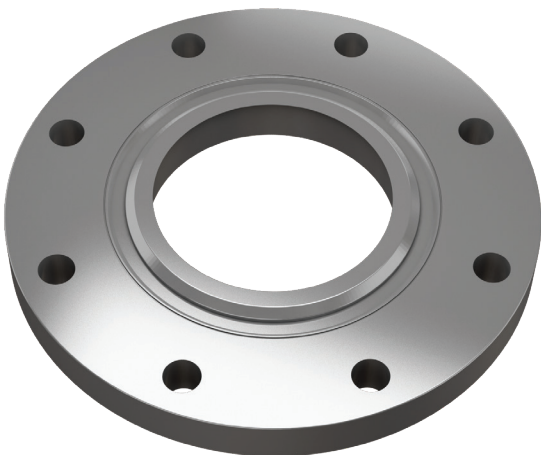

## Tek-DP 1610C series Orifice Plate Types

Orifice plates are available in paddle type and universal type. Paddle type plates are designed for using in orifice flanges whereas universal type orifice plates are meant for use in orifice plate holders.

### Classification of Orifice Plates Depending on Bore Type:

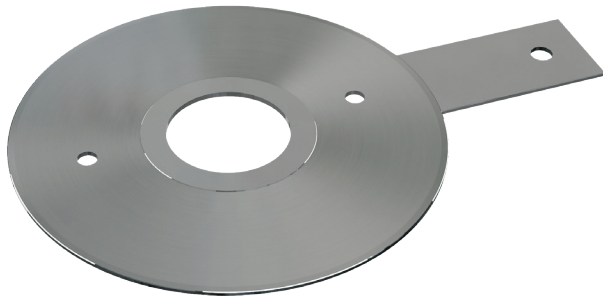

- **Concentric**

Concentric is the most commonly used orifice plate type and is suitable in most processes except highly corrosive medium and slurries.

- **Eccentric**

The hole is positioned off-centred in case of the eccentric orifice. This allows undesired portion of fluid to pass through the orifice and prevents accumulating on upstream face.

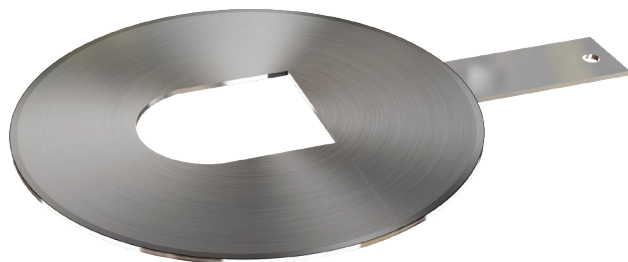
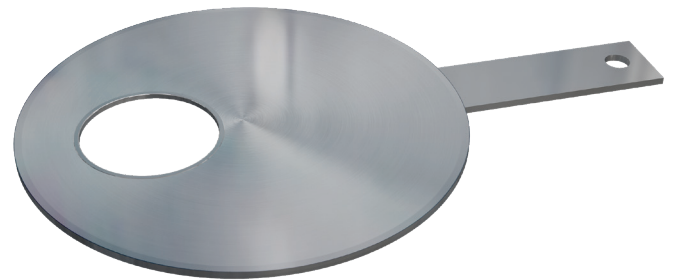

- **Segmental**

Segmental orifice uses a segment of a concentric circle as a hole rather than a circular hole. It is useful in case of colloidal and slurry flow applications.

### Classification of Orifice Plates Depending on Bore Profile:

- **Square-Edge**

Square-edge orifice has a sharp edge and appears exactly same from either directions. It can be used for measurement of bi-directional fluid flow rates. The square-edge orifice minimizes contact with the fast moving fluid stream going through the hole.



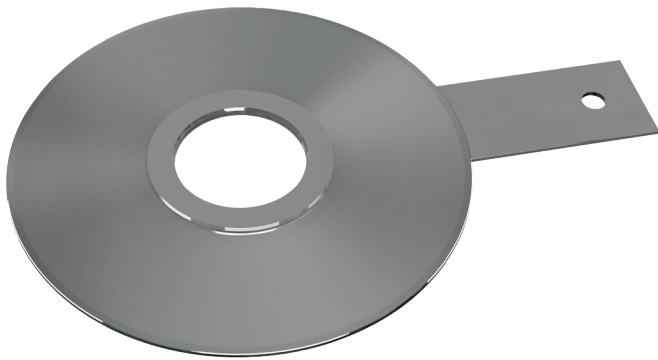

- **Conical entrance**

Conical entrance orifice contains conical-edge entrance and square-edge exit. It looks like beveled square-edge orifice plate installed backwards. These are effective for measurement of viscous fluids and lower Reynolds numbers 80 to 2000.

- **Quadrant-Edge**

The edge of the bore of Quadrant-edge orifice, on the other hand, is rounded to quarter circle. This design makes is effective in viscous fluids and Reynolds number between 1000 to 2000.

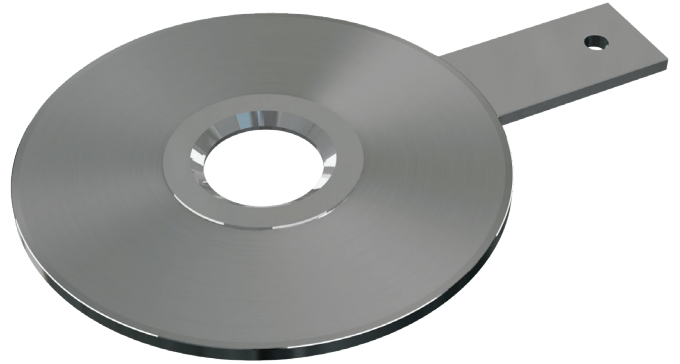

## Benefits

- **Orifice Flanges**

- Compatible with orifice plate carriers
- Provide leak-proof connection
- Available in flat face, raised face, and ring type joint face
- Available in all pipe diameter sizes

- **Orifice Plates**

- Suitable for various conditions such as liquids, viscous fluids, suspended solids, and gases
- Less costly compared to various other flow measurement instruments
- No maintenance cost
- Robust design

## Applications

DP flowmeters offer optimized performance in a wide range of industrial applications. To mention a few:

- Oil and Gas flow metering in subsea, onshore and offshore applications
- Water and waste-water treatment plants
- Sprinkler systems for flow control
- Remote sensing of central heating systems for air, steam or water
- Monitoring and controlling pressure drops across valves
- Custody transfers: Selling products on weight or volume
- Pharmaceutical, Food/Beverages industry for maintaining product consistency and proportions

# Dimensional Drawing

## • Orifice Flanges

### Raised Face Weld Neck Orifice Flanges

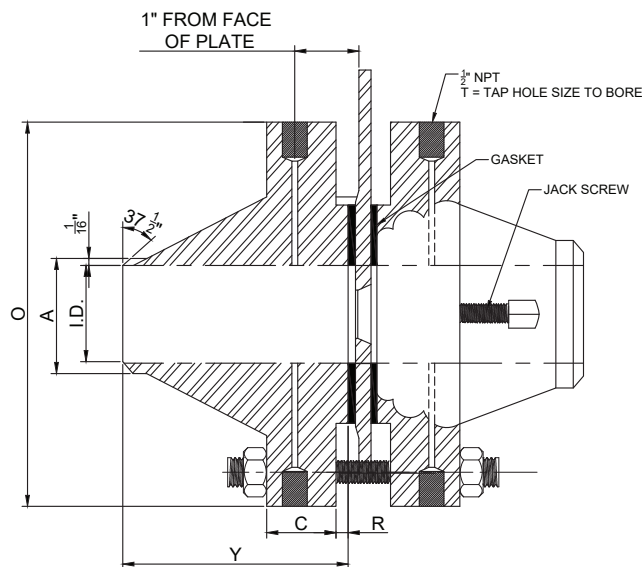

Line Size	Line I.D. Standard Sch. ± Tolerance	Flange Diameter	Flange Thickness	Raised Face Diameter	Length Through Hub	Hub Diameter at Base	Weld Neck Diameter	Tap Hole Size	Flange Bolting				Jackscrew Size	Weight (Pounds)
									Bolt Hole Circle Diameter	Hole Diameter	Bolt Holes	Stud Bolt Size		
	I.D.	O	C*		Y*		A	T						
1/2	0.622	3 3/4	1 1/2	3 3/8	3	1 1/2	0.84	1/4	2 5/8	9/16	4	1/2 x 4 3/4	1/2 x 3	10
3/4	0.824	4 5/8	1 1/2	1 11/16	3 1/8	1 7/8	1.05	1/4	3 1/4	11/16	4	5/8 x 5	1/2 x 3	10
1	1.049	4 7/8	1 1/2	3	3 1/4	2 1/8	1.32	1/4	3 1/2	11/16	4	5/8 x 5	5/8 x 3	18
1 1/2	1.610	6 1/8	1 1/2	2 7/8	3 3/8	2 3/4	1.90	1/4	4 1/2	13/16	4	3/4 x 5 1/4	5/8 x 3	25
2	2.067	6 1/2	1 1/2	3 5/8	3 3/8	3 5/16	2.38	3/8	5	11/16	8	5/8 x 5	5/8 x 3	27
2 1/2	2.469	7 1/2	1 1/2	4 1/8	3 1/2	3 15/16	2.88	3/8	5 7/8	13/16	8	3/4 x 5 1/4	5/8 x 3	35
3	3.068	8 1/4	1 1/2	5	3 1/2	4 5/8	3.50	3/8	6 5/8	13/16	8	3/4 x 5 1/4	3/4 x 3	43
4	4.026	10	1 1/2	6 3/16	3 5/8	5 3/4	4.50	1/2	7 7/8	13/16	8	3/4 x 5 1/4	3/4 x 3	66
6	6.065	12 1/2	1 1/2	8 1/2	3 15/16	8 1/8	6.63	1/2	10 5/8	7/8	12	3/4 x 5 1/4	3/4 x 3	106
8	7.981	15	1 5/8	10 5/8	4 3/8	10 1/4	8.63	1/2	13	1	12	7/8 x 5 3/4	3/4 x 3	152
10	10.020	17 1/2	1 7/8	12 3/4	4 5/8	12 5/8	10.75	1/2	15 1/4	1 1/8	16	1 x 6 3/4	1 x 4 1/2	216
12	12.000	20 1/2	2	15	5 1/8	14 3/4	12.75	1/2	17 3/4	1 1/4	16	1 1/8 x 7 1/4	1 x 4 1/2	327
14	13.250	23	2 1/8	16 1/4	5 5/8	16 3/4	14.00	1/2	20 1/4	1 1/4	20	1 1/8 x 7 1/2	1 x 4 1/2	448
16	15.250	15 1/2	2 1/4	18 1/2	5 3/4	19	16.00	1/2	22 1/2	1 3/8	20	1 1/4 x 8 1/4	1 x 4 1/2	596
18	17.250	28	2 3/8	21	6 1/4	21	18.00	1/2	24 3/4	1 3/8	24	1 1/4 x 8 1/2	1 x 4 1/2	741
20	19.250	30 1/2	2 1/2	23	6 3/8	23 1/8	20.00	1/2	27	1 3/8	24	1 1/4 x 8 3/4	1 x 4 1/2	887
24	23.250													

\*Note: Class 300 flanges, C and Y dimensions include 1/16" raised face

## Ring-Type Joint Weld Neck Orifice Flanges

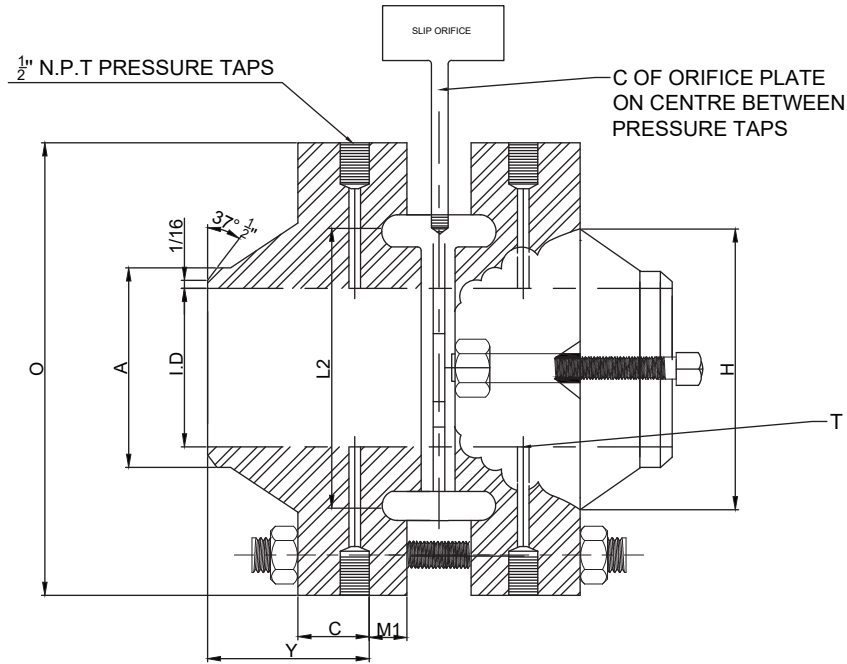

Line Size (inch)	API Ring Numbers	Line I.D. and Tolerance	Flange Diameter	Flange Thickness	Length Through Hub	Hub Diameter at Base	Weld Neck Diameter	Pitch Diameter of Ring and Groove	Depth of Groove	Tap Hole Size	Flange Bolting				Jackscrew Size	Weight (Pounds)
											Bolt Hole Circle Diameter	Hole Diameter	Number of Holes	Stud Bolt Size		
		I.D.	O	C*	Y*	H	A	L <sub>2</sub>	M <sub>1</sub>	T						
1	R-18	† ± .003	6 <sup>1</sup> / <sub>4</sub>	1 <sup>1</sup> / <sub>2</sub>	3 <sup>5</sup> / <sub>8</sub>	2 <sup>1</sup> / <sub>4</sub>	1.32	2 <sup>3</sup> / <sub>8</sub>	1/4	1/4	4 <sup>1</sup> / <sub>4</sub>	1	4	7/8 x 6 <sup>1</sup> / <sub>4</sub>	5/8 x 4	26
1 1/2	R-23	† ± .003	8	1 <sup>3</sup> / <sub>4</sub>	4 <sup>3</sup> / <sub>8</sub>	3 <sup>3</sup> / <sub>8</sub>	1.90	3 <sup>1</sup> / <sub>4</sub>	5/16	1/4	5 <sup>3</sup> / <sub>4</sub>	1 <sup>1</sup> / <sub>4</sub>	4	1 <sup>1</sup> / <sub>8</sub> x 7 <sup>1</sup> / <sub>2</sub>	3/4 x 4 <sup>1</sup> / <sub>2</sub>	56
2	R-26	† ± .003	9 <sup>1</sup> / <sub>4</sub>	2	5	3 <sup>3</sup> / <sub>4</sub>	2.38	4	5/16	3/8	6 <sup>3</sup> / <sub>4</sub>	1 <sup>1</sup> / <sub>8</sub>	8	1 x 7 <sup>3</sup> / <sub>4</sub>	3/4 x 4 <sup>1</sup> / <sub>2</sub>	84
2 1/2	R-28	† ± .003	10 1/2	2 <sup>1</sup> / <sub>4</sub>	5 <sup>5</sup> / <sub>8</sub>	4 <sup>1</sup> / <sub>2</sub>	2.88	4 3/4	3/8	3/8	7 <sup>3</sup> / <sub>4</sub>	1 <sup>1</sup> / <sub>4</sub>	8	1 <sup>1</sup> / <sub>8</sub> x 8 <sup>3</sup> / <sub>4</sub>	3/4 x 5 <sup>1</sup> / <sub>2</sub>	104
3	R-32	† ± .003	12	2 <sup>5</sup> / <sub>8</sub>	6 <sup>5</sup> / <sub>8</sub>	5 <sup>1</sup> / <sub>4</sub>	3.50	5	3/8	3/8	9	1 <sup>3</sup> / <sub>8</sub>	8	1 <sup>1</sup> / <sub>4</sub> x 9 <sup>3</sup> / <sub>4</sub>	3/4 x 7	188
4	R-38	† ± .004	14	3	7 <sup>1</sup> / <sub>2</sub>	6 <sup>1</sup> / <sub>2</sub>	4.50	6 <sup>3</sup> / <sub>16</sub>	7/16	1/2	10 <sup>3</sup> / <sub>4</sub>	1 <sup>5</sup> / <sub>8</sub>	8	1 <sup>1</sup> / <sub>2</sub> x 11	3/4 x 7	292
6**	R-47	† ± .004	19	4 <sup>1</sup> / <sub>4</sub>	10 <sup>3</sup> / <sub>4</sub>	9 <sup>1</sup> / <sub>4</sub>	6.63	9	1/2	1/2	14 <sup>1</sup> / <sub>2</sub>	2 <sup>1</sup> / <sub>8</sub>	8	2 x 14 <sup>3</sup> / <sub>4</sub>	3/4 x 9	756
8**	R-51	† ± .004	21 <sup>3</sup> / <sub>4</sub>	5	12 <sup>1</sup> / <sub>2</sub>	12	8.63	11	9/16	1/2	17 <sup>1</sup> / <sub>4</sub>	2 <sup>1</sup> / <sub>8</sub>	12	2 x 16 <sup>3</sup> / <sub>4</sub>	1 x 10	1152
10**	R-55	† ± .005	26 <sup>1</sup> / <sub>2</sub>	6 <sup>1</sup> / <sub>2</sub>	16 <sup>1</sup> / <sub>2</sub>	14 <sup>3</sup> / <sub>4</sub>	10.75	13 <sup>1</sup> / <sub>2</sub>	11/16	1/2	21 <sup>1</sup> / <sub>4</sub>	2 <sup>5</sup> / <sub>8</sub>	12	2 <sup>1</sup> / <sub>2</sub> x 21 <sup>1</sup> / <sub>4</sub>	1 x 13	2136
12**	R-60	† ± .005	30	7 <sup>1</sup> / <sub>4</sub>	18 <sup>1</sup> / <sub>4</sub>	17 <sup>3</sup> / <sub>8</sub>	12.75	16	11/16	1/2	24 <sup>3</sup> / <sub>8</sub>	2 <sup>7</sup> / <sub>8</sub>	12	2 <sup>3</sup> / <sub>4</sub> x 23 <sup>1</sup> / <sub>4</sub>	1 x 13	3216

\* Does not include depth of Ring Groove.

\*\* Tap hole location exceeds A.G.A. limits due to Ring Groove interference. Tap hole location from the plate is as follows: 6"-1<sup>1</sup>/<sub>8</sub>", 8"-1<sup>1</sup>/<sub>8</sub>", 10"-1<sup>1</sup>/<sub>4</sub>", 12"-1<sup>1</sup>/<sub>4</sub>.

† To be specified by purchaser.

**Note:** 4"-12" SP 250 JW Orifice Flanges are not recognized by ANSI B16.36.



## Slip-On Orifice Flanges Assemblies

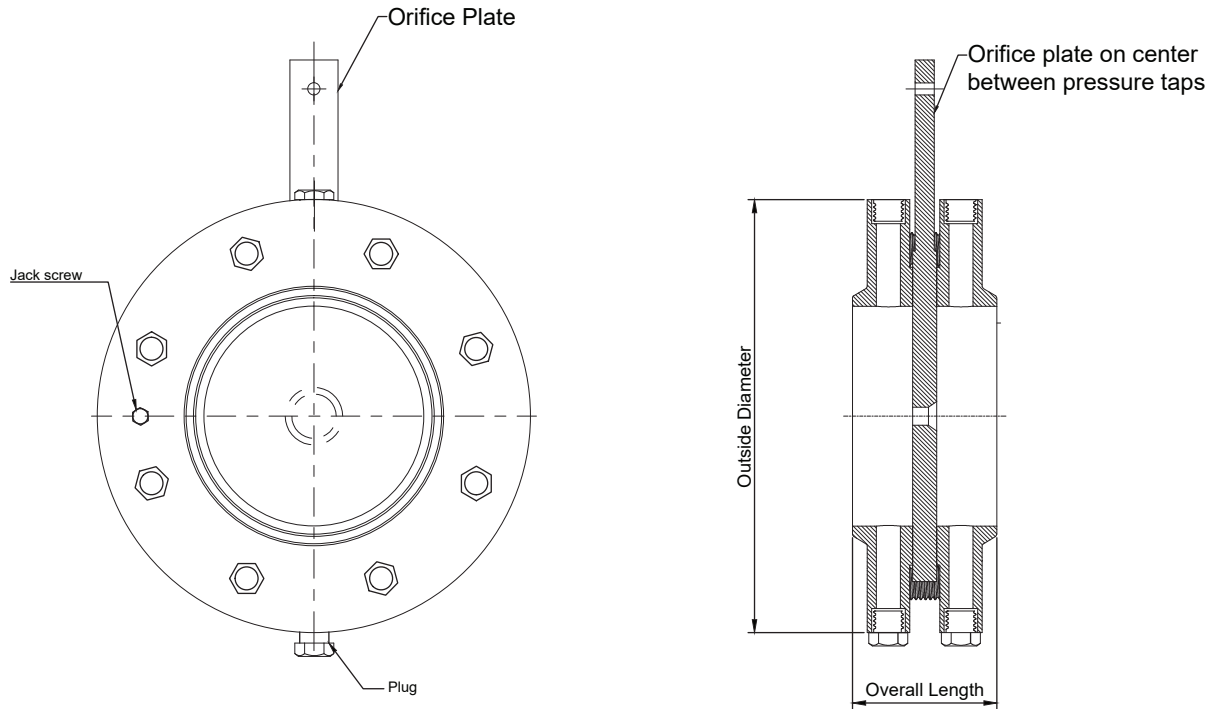

Nominal Size		Slip-On Orifice Flanges - 300 lb RF				
		Bolts		Approx Weight	Outside Diameter	Overall Length
Feet	Inch	Bolt Qty.	Bolt Size	Kg		
0.08	1	4	5/8" x 4"	7.5	102	124
0.13	1 1/2	4	3/4" x 5.25"	9.3	102	155
0.16	2	8	5/8" x 5.00"	11.5	105	165
0.21	2 1/2	8	3/4" x 5.25"	15	108	191
0.26	3	8	3/4" x 5.25"	19	111	210
0.32	4	8	3/4" x 5.25"	29	114	254
0.49	6	12	3/4" x 5.25"	50	114	318
0.65	8	12	7/8" x 5.75"	65	130	381
0.82	10	16	1" x 6.50"	91	139	445
0.98	12	16	1 1/8" x 7.00"	133	152	521
1.14	14	20	1 1/8" x 7.25"	177	158	584
1.31	16	20	1 1/4" x 7.75"	240	171	648
1.47	18	24	1 1/4" x 8.00"	323	184	711
1.64	20	24	1 1/4" x 8.50"	360	197	775
1.96	24	24	1 1/2" x 9.50"	555	219	914

• Orifice Plates

Paddle Type Orifice Plate

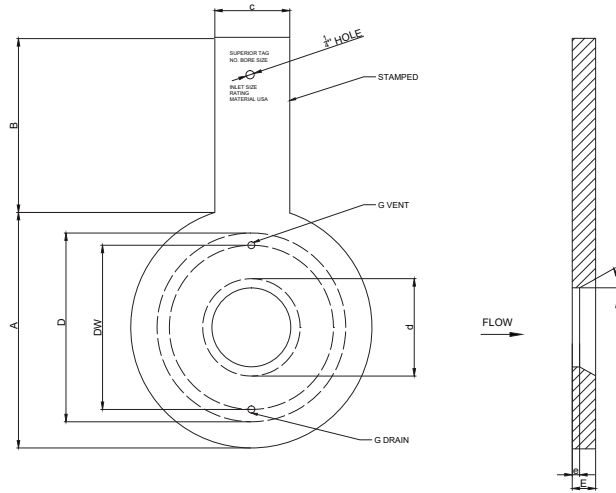

ORIFICE PLATE DIMENSIONS										
Line Size (Inch)	A					E	e	B	C	Max Difference LBS $\beta = .50$
	125/150 #	300#	600#	900 #	1500#					
1/2	1 - 7/8	2 - 1/8	2 - 1/8	2 - 1/2	2 - 1/2	1/8	1/32	4	1	7596
3/4	2 - 1/4	2 - 5/8	2 - 5/8	2 - 3/4	2 - 3/4	1/8	1/32	4	1	4113
1	2 - 5/8	2 - 7/8	2 - 7/8	3 - 1/8	3 - 1/8	1/8	1/32	4	1	2051
1 1/2	3 - 3/8	3 - 3/4	3 - 3/4	3 - 7/8	3 - 7/8	1/8	1/32	4	1	890
2	4 - 1/8	4 - 3/8	4 - 3/8	5 - 5/8	5 - 5/8	1/8	1/32	4	1 - 1/4	530
3	5 - 3/8	5 - 7/8	5 - 7/8	6 - 5/8	6 - 7/8	1/8	1/32	4	1 - 1/4	240
4	6 - 7/8	7 - 1/8	7 - 5/8	8 - 1/8	8 - 1/4	1/8	1/16	4	1 - 1/4	112
6	8 - 3/4	9 - 7/8	10 - 1/2	11 - 3/8	11 - 1/8	1/8	3/32	5	1 - 1/4	61
8	11	12 - 1/8	12 - 5/8	14 - 1/8	13 - 7/8	1/8	1/8	4	1 - 1/4	35
10	13 - 3/8	14 - 1/4	15 - 3/4	17 - 1/8	17 - 1/8	1/8	1/8	6	1 - 1/4	22
12	16 - 1/8	16 - 5/8	18	19 - 5/8	20 - 1/2	1/4	1/8	6	1 - 1/4	63
14	17 - 3/4	19 - 1/8	19 - 3/8	20 - 1/2	22 - 3/4	1/4	1/8	6	1 - 1/4	51
16	20 - 1/4	21 - 1/4	22 - 1/4	22 - 5/8	25 - 1/4	1/4	1/4	6	1 - 1/4	38
18	21 - 1/2	23 - 3/8	24	25	27 - 5/8	1/4	1/4	6	1 - 1/4	30
20	23 - 3/4	25 - 5/8	26 - 3/4	27 - 3/8	29 - 5/8	3/8	1/4	6	1 - 1/4	14
24	28 - 1/8	30 - 3/8	31	32 - 7/8	35 - 1/2	3/8	1/4	6	1 - 1/4	13

WEEP HOLE DIMENSIONS			
d Orifice Bore	G Maximum Diameter	d Orifice Bore	G Maximum Diameter
Les than 1.000	Not Recomendad	8.376 - 9.250	5/16
1.000 - 3.500	3/32	9.251 - 10.000	11/32
3.501 - 4.125	1/8	10.001 - 10.875	3/8
4.125 - 5.000	5/32	10.876 - 11.625	13/32
5.001 - 6.000	3/16	11.626 - 12.500	7/16
6.001 - 6.750	7/32	12.501 - 13.250	15/32
6.751 - 7.500	1/4	13.251 +	1/2
7.501 - 8.375	9/32		

## Universal Type Orifice Plate

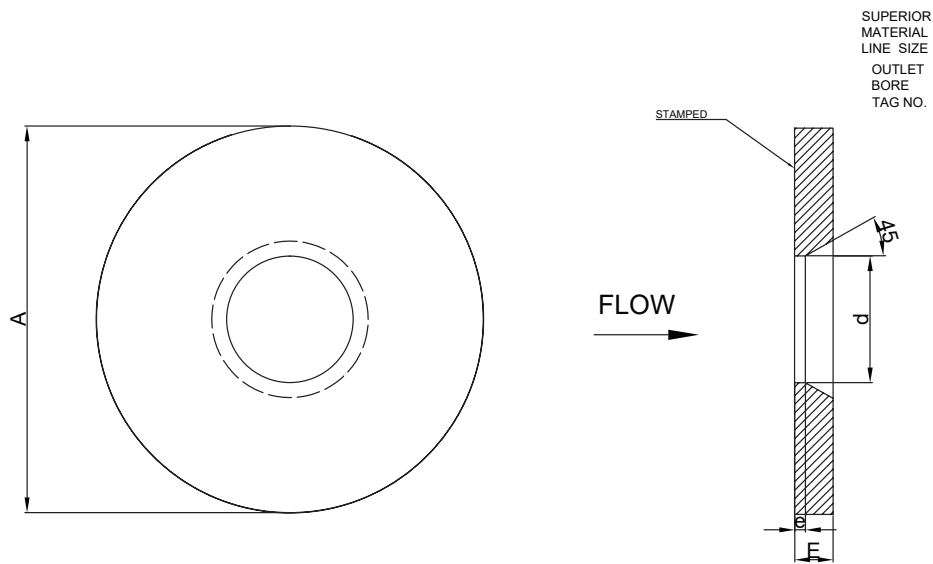

Line Size (Inches)	Plate O.D.	Plate Thickness	Blank WT LBS
	A	E	
2	2.437	1/8	.17
3	3.437	1/8	.34
4	4.406	1/8	.55
6	6.437	1/8	1.18
8	8.437	1/8	2.03
10	10.687	1/8	3.25
12*	13.079	1/4	9.02
14*	14.563	1/4	11.16
16*	16.563	1/4	14.58
18*	18.563	1/4	18.45
20*	2.563	3/8	22.78
24*	24.500	3/8	32.80
26*	26.750	3/8	62.00
30*	30.750	1/2	112.00
34*	35.228	1/2	134.00
36*	38.000	1/2	156.00

\*"A" dimension for 12 inch and larger Orifice Plates above include the Vulcanized Seal. Upon request Teflon and Metal Seals can be manufactured for Orifice Plates 12 inch and larger.

## Specifications

### • Orifice Flanges

Size	1" to 96" diameter, On Customer Request
Material	A105, A305 LF2, 304/304L, 316/316/L, On Customer Request
Pressure Tappings	Standard two 1/2" NPT tappings
Gaskets	1.5 mm thick IBC ring type, non asbestos - 3.2 mm thick spiral wound type, carbon steel outer, stainless steel inner, 316L windings with graphite filler

## • Orifice Plates

### Universal Type Orifice Plate

<b>Size</b>	Up to 96" diameter
<b>Material</b>	Stocked in T-304, T-304L, T-316, T-316L, T-321, T-410, Alloy-20, Hastelloy B and C, Monel, and Titanium
<b>Bore</b>	Concentric, Eccentric, Quadrant

### Paddle Type Orifice Plate

<b>Size</b>	Up to 96" diameter
<b>Material</b>	Stocked in T-304, T-304L, T-316, T-316L, T-321, T-410, Alloy-20, Hastelloy B and C, Monel, and Titanium
<b>Bore</b>	Concentric, Eccentric, Quadrant, Segmental

## Installation Guidelines

- Ensure that the operating staff handling this pressurized instrument is professionally trained and alert while operating
- Face orifice flanges in front of each other and install studs in the lower half
- Insert the orifice plate and gaskets in the orifice plate holder existing between the two flanges
- Ensure that the orifice bore is centered well with the pipe diameter
- Install remaining studs around the orifice flanges with bolts
- Tighten the flange bolts evenly without distorting the plate alignment
- Place the pressure sensors in the pressure tap holes provided on either ends of flanges
- Ensure that all screws and studs are tightened and the system is leak-proof before pressurizing the flow pipe. Use new gaskets every time orifice flange is separated.

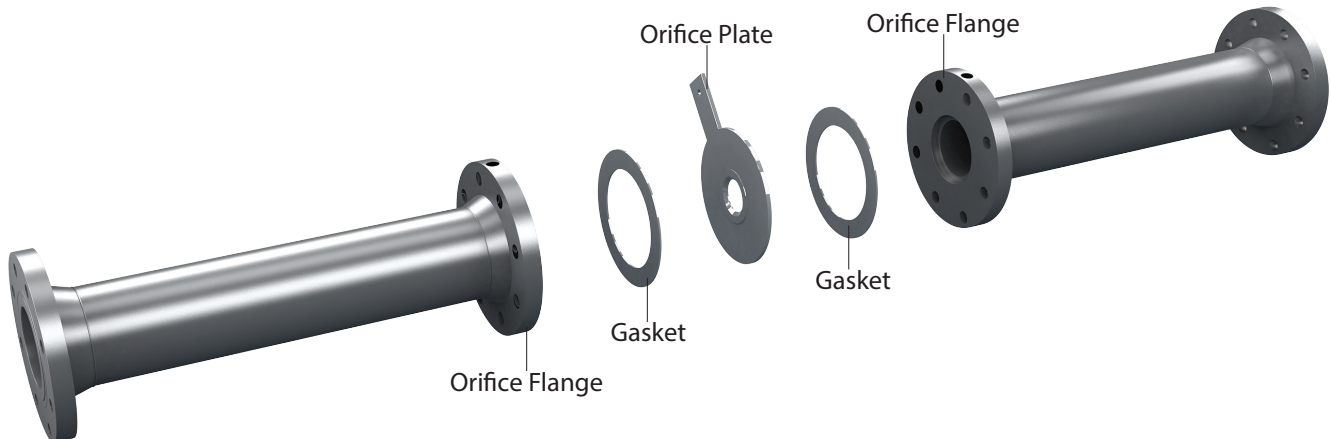

Take the following precautions while installing:

Ensure that

- The alignment of the assembly to avoid cracks in the pipe
- The bolts are tight enough but not over torqued
- The flow direction arrow is orientated in the direction of fluid flow
- The 'Inlet' stamped on the orifice plate faces towards inlet flange
- The pressure taps are horizontal to prevent wrong pressure reading

# Customer Service and Support



TEKMATION LLC reserves the right to change the designs and/or materials of its products without notice. The contents of this publication are the property of TEKMATON and cannot be reproduced by any other party without written permission. All rights reserved. Copyright © 2016 TEKMATON LLC  
TEKMATION LLC  
DOC # TEK/ITPS/2405/2016/10C/01



[www.tek-trol.com](http://www.tek-trol.com)

Tek-Trol is a fully owned subsidiary of TEKMATON LLC. We offer our customers a comprehensive range of products and solutions for process, power, and oil and gas industries. Tek-Trol provides process measurement and control products for Flow, Level, Temperature and Pressure Measurement, Control Valves, and Analyzer systems. We are present in 15 locations globally and are known for our knowledge, innovative solutions, reliable products, and global presence.

## **Tek-Trol LLC**

796 Tek Drive Crystal Lake, IL 60014 USA

Tel: +1 847 857 6076, Fax: +1 847 655 6147

Email: [tektrol@tek-trol.com](mailto:tektrol@tek-trol.com)

[www.tek-trol.com](http://www.tek-trol.com)