



Technology Solutions

# TEK-DP 1630A

## Flow Nozzle



FLOW

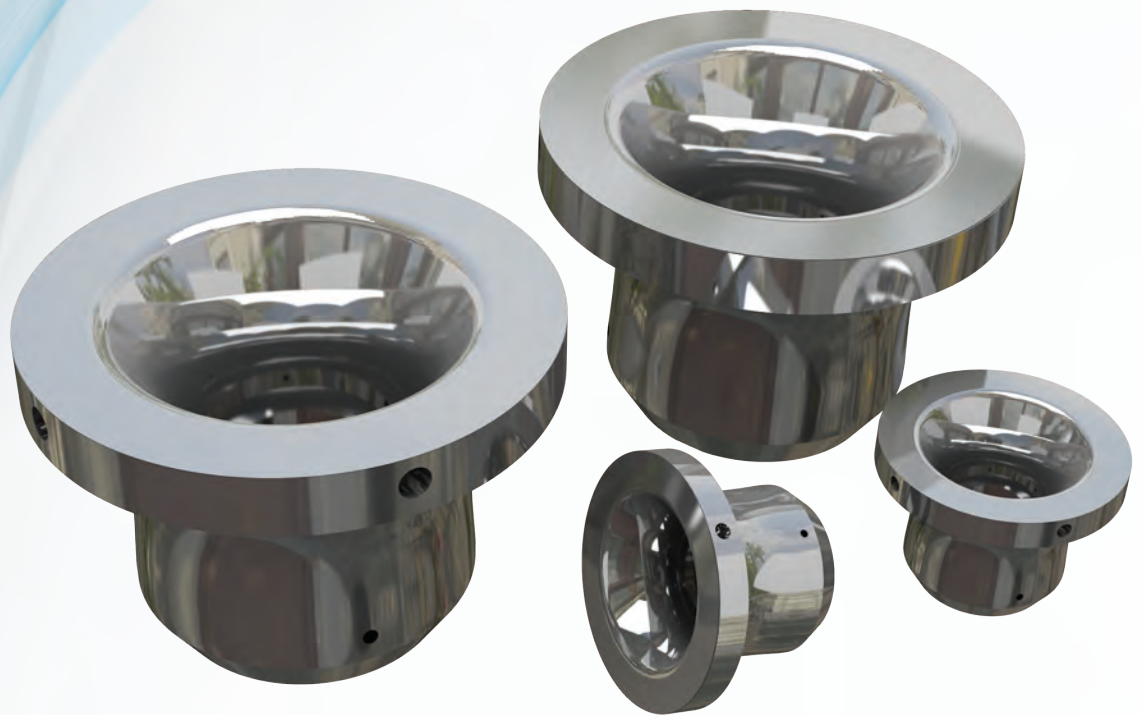



Fig 1. Flow Nozzles

## Flow Nozzle

Tek-Trol Flow Nozzles are designed to provide highly accurate flow measurements over a wide range of flows and differential pressures, making them ideal for heavy-duty applications with high flows rates. We offer a variety of sizes and construction materials to suit different installation requirements, and our Flow Nozzles are easy to install and maintain. These flow nozzles are calculated, designed, and manufactured in accordance with ASME or ISO 5167 recommendations to ensure high-accuracy flow measurement. Tek-DP 1630A Flow Nozzles are available in a large range of sizes to accommodate different pipe diameters and installations. All Tek-Trol 1630A nozzles are constructed from high-quality traceable materials per process application, to withstand harsh operating conditions and ensure long-term reliability and repeatability.

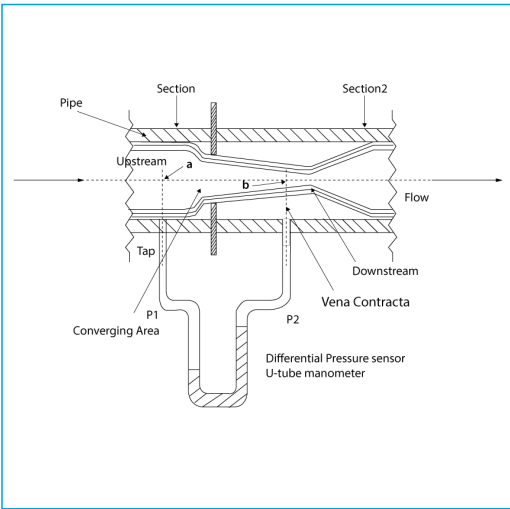

Fig 2. Measuring Principle

## Measuring Principle

Flow Nozzles operate by using the principle of differential pressure measurement. It is based on the Bernoulli theory of conservation of mass and energy in a closed pipe. As predicted by Bernoulli's principle, pressure decreases when there is an increase in flow velocity due to a constriction or area reduction in a flowing pipe (i.e.,  $V_2 > V_1$ ), thereby creating a pressure drop (DP) which can be measured by using a Tek-Trol DP Transmitter. From this data the flow rate can be determined by measuring the static pressures at the cross-sectional area upstream. Temperature measurement and correction may also be required to provide an accurate flow measurement.

Bernoulli described the relationship between differential pressure and flow rate by the following equation:

$$\Delta p \propto Q_m^2$$

The differential pressure generated,  $\Delta p$ , is proportional to the square of mass flow rate,  $Q_m$ . In simple terms, for a given size of restriction, higher the  $\Delta p$ , higher is the flow rate.

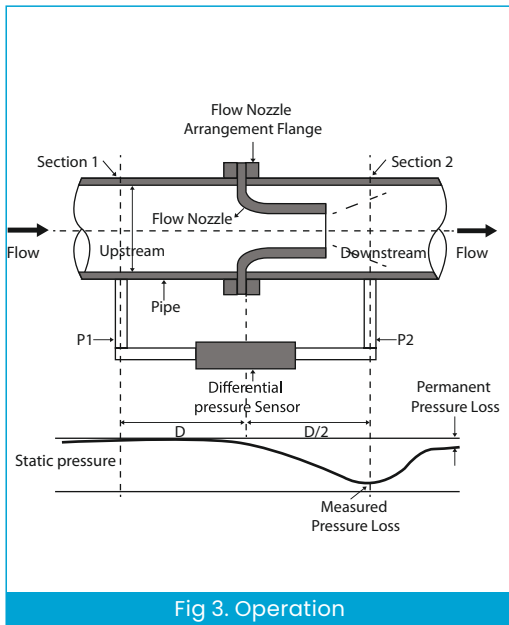

Fig 3. Operation

## Flow Nozzle

A flow nozzle is a tube or a pipe of varying cross-sectional area with the minimum cross-sectional area at its throat. It has an elliptically contoured inlet and a cylindrical throat section, which acts as a restriction to the fluid-flow creating a pressure drop. The flow nozzle is placed inside the pipe or is positioned between the two flanges. The pipeline should be completely filled with the fluid to be measured when operating the device.

A differential pressure sensor is attached between the two points, P1 and P2, for determining the differential pressure of a fluid the flowing fluid (gas or liquid).

The fluid passes through the reduction in area created by the flow nozzle which results in a pressure drop, which varies with the flow

The flow contracts to pass through the nozzle and the velocity increases. The flow converges at the throat and then expands again to rejoin the pipe wall. The DP sensor measures the pressure of the upstream and downstream flow. The differential pressure ( $P1 - P2$ ) is proportional to the flow rate and can be determined by mathematical equations and appropriate calibration. The relationship between the internal pipe diameter and the nozzle diameter is called the Beta or Area Ratio. ( $\beta$ ) and is the nozzle constriction internal diameter divided by the pipe internal diameter ( $d/D$ ) as per Fig 3.

## Flanged and Holding Ring Nozzle Types

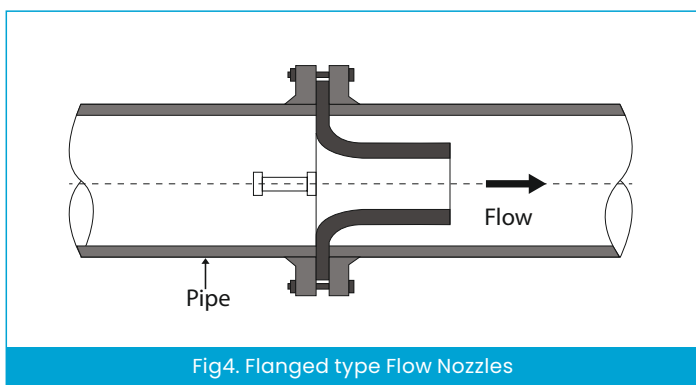

Fig4. Flanged type Flow Nozzles

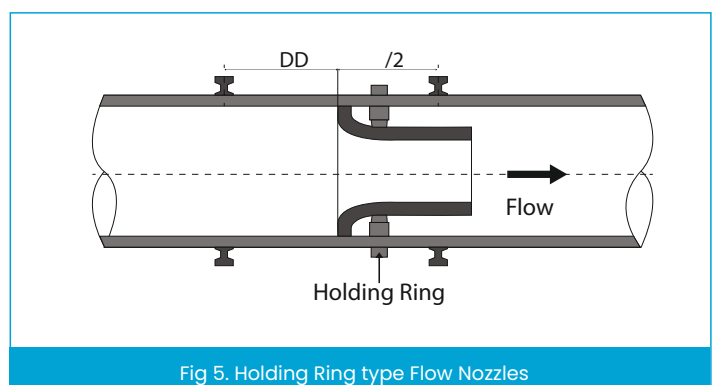

Fig 5. Holding Ring type Flow Nozzles

This is the simplest flow nozzle design/install where the nozzle is inserted between the two pipe flanges and connection is tightened using correctly rated nuts and bolts and sealed with appropriate gaskets. These types are commonly used with pipe wall taps for the static and differential pressure connections.

These flow nozzle types are installed into the pipeline without flanges. The nozzle is installed with the help of a holding ring and locating pins made of the same material as that of the pipe, which eliminates material dissimilarities. These nozzle types have a high beta ratio. and are suitable for medium to large pipe diameter sizes.

## Weld-in Nozzle Types

These nozzle types have a machined tongue around its largest diameter. The nozzle is inserted inside the pipe section and then it is firmly clamped and welded. This design of nozzle is appropriate in high-temperature, high-pressure application where flange type connections may be risky.

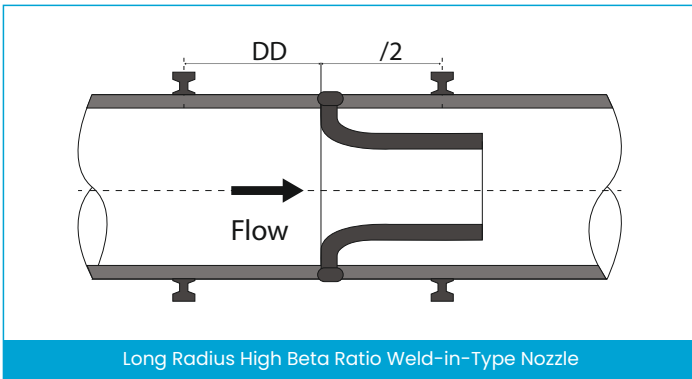

Long Radius High Beta Ratio Weld-in-Type Nozzle

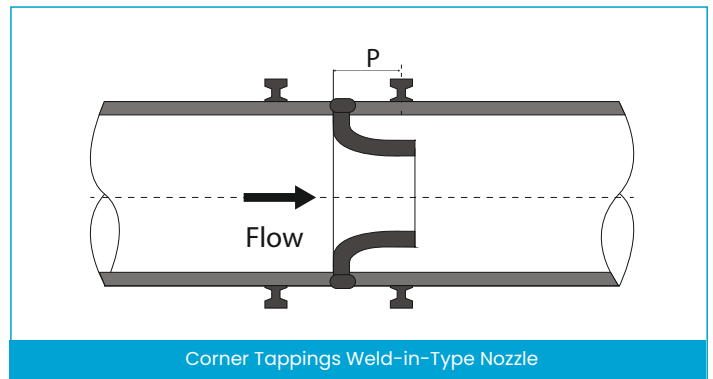

Corner Tappings Weld-in-Type Nozzle

### Features

- ▶ Suitable for Gas and Liquid High Quality Flow Measurement
- ▶ Applicable for high-pressure and high velocity, low-viscous / erosive process measurement
- ▶ Low Line Pressure Loss
- ▶ Large Fluid Type Flexibility
- ▶ Low maintenance no moving parts
- ▶ Easy Installation

### Applications

- ▶ Power Stations
- ▶ Petrochemical Plants
- ▶ Steam and Condensate Flows
- ▶ Water Supply and Treatment
- ▶ Gas Processing and Transfer
- ▶ Petrochemical - Refining
- ▶ Crude Oil Processes

### Dimensions Drawing

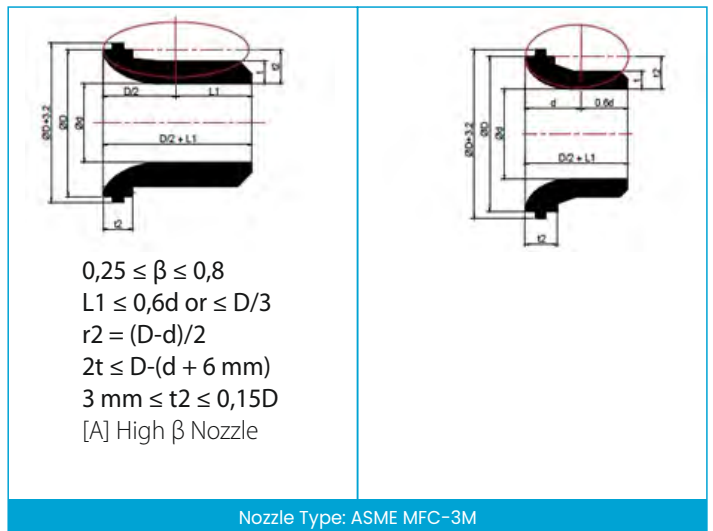
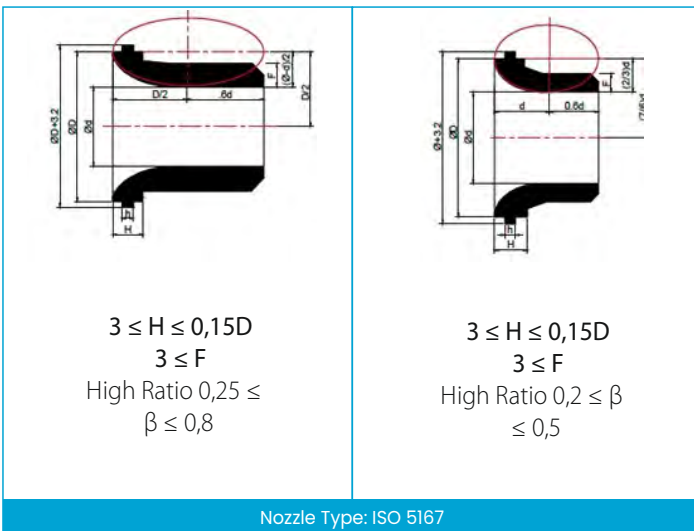

## Flow Nozzle Assembly Dimensions

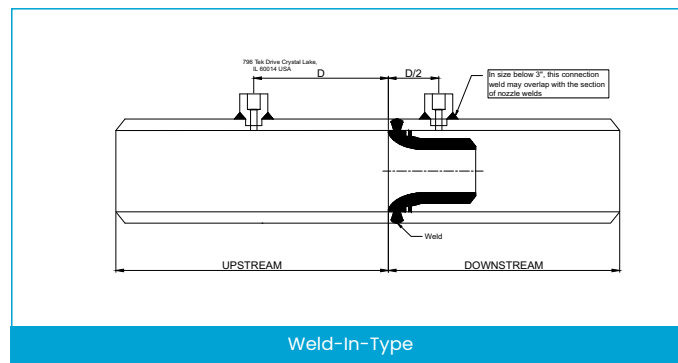
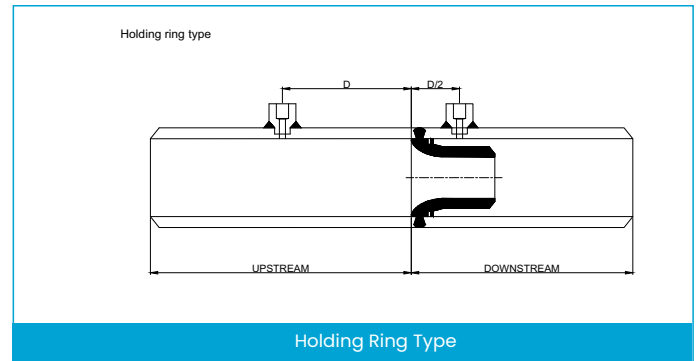
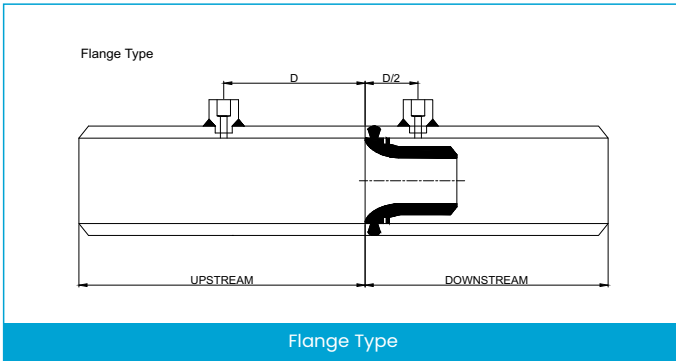

## Specification

Accuracy	Typical accuracy is 1-2% of full range flow measurement uncertainties of $\pm 0.25\%$ of the actual flow rate are available when flow calibrated.
Design	Design calculations based on the following standards: ISO 5167-3, ASME MFC3, ASME B31.1, B31.3, or other standards, as required.
Pressure Ratings	Ranging from ANSI 150# to API 15000 PSI, Consult factory for special pressure applications
Flow Turndown	Typically, $>10:1$ , depending on the Transmitter configuration and rangeability
Pipe Materials	A216 WCB, A216 WCC, A352 LCC, A358 CF8M, A995 Gr4A, A995 Gr6A, Custom: Duplex stainless steels etc.
Nozzle Material	AISI 4130 Carbon Steel, 316 or A351 Stainless Steels, Custom
Tap Connections	Two $\frac{1}{2}$ " NPT (high / low pressure) per standard design
Pipe Sizes	1" to 48", Custom sizes available for special applications
Manufacturing Standard	ISO-5167 Part 3, ASME PTC-19.5, ASME PTC-6
Operating Temperature	-250 °C to +650 °C (-425 °F to +1200 °F) nozzle material dependent
Operating Position	Vertical or horizontal
Process products	Liquid, Gas, Steam
Assembly Type	Flange, Welded , Holding Ring
End Connection	Flanged end, Socket welded, Butt welded

## Installation Guidelines

- ▶ Make sure that the operational staff handling the instrument are properly trained and alert while operating the flow meter.
- ▶ A flow nozzle is a piping component that is installed between the upstream and downstream meter run sections and may be under positive pressure always check the line pressure condition before installation.
- ▶ Place the device in line with the two flange taps correctly positioned with the instruction plate facing in an upward direction.
- ▶ Do not use the device as a flow pipe support, do not subject it to shocks and vibrations.
- ▶ Ensure that the pressure taps are positioned below the horizontal centerline.
- ▶ While filling the pipeline, do not over-pressurize the flow meter. Ensure that no air bubble is trapped in case of a fluid medium.
- ▶ Verify the connections before starting the operation. Ensure that the assembly is leakage-free.
- ▶ If the flow nozzle has to be removed from the line for any reason, depressurize the line and drain it completely.
- ▶ Use strings and strapping provided with the product kit, to move the meter



## Model Chart

Example	Tek-DP1630A	A	01	01	XX	01	01	A	01	A	Tek-DP 1630A-A-01-01-XX-01-01-A-01-A
Model		A B C									Weld In Type Holding Ring Flanged Type
Meter Run			01 02								Element Only Meter Run Included
Line Size				01 02 03 04							50 80 100 600
Nominal Pipe Size					XX						Special
Nozzle Material						01 02 03 04 05 06 07 08 09 XX					A105 A182 F304 A182 F304L A182 F316 A182 F316L A182 F11 A182 F22 A182 F51 A182 F91 Special
Nozzle Type							01 02 03				Long Radius High Beta ISA 1932 Long Radius Low Beta
Meter Run Material								A B C D E F X			A 53 Gr B A 106 Gr B A 335 P11 A 335 P22 A 335 P51 A 335 P91 Special
Diff Type									01 02 03 04		NPT ½ NPT ¾ SW 1½ SW ¾
Flanged Type /Rating										A B C D E F	Flange Rating NA- Welding Type 300# - WN - RF/RTJ 600# - WN - RF/RTJ 900# - WN - RF/RTJ 1500# - WN - RF/RTJ 2500# - WN - RF/RTJ

# Customer Service & Support



TEK-TROL LLC reserves the right to change the designs and/or materials of its products without notice. The contents of this publication are the property of TEK-TROL LLC and cannot be reproduced by any other party without written permission. All rights reserved. Copyright © 2021 TEK-TROL LLC  
TEK-TROL LLC  
DOC # TEK/ITPS/CAT/240520/1630A/01.1



[www.tek-trol.com](http://www.tek-trol.com)

## **Tek-Trol LLC**

796 Tek Drive Crystal Lake,  
IL 60014, USA

 +1 847-857-6076

 [tektrol@tek-trol.com](mailto:tektrol@tek-trol.com)

 [www.tek-trol.com](http://www.tek-trol.com)

Tek-Trol is a fully owned subsidiary of TEKMATIION LLC. We offer our customers a comprehensive range of products and solutions for process, power and oil & gas industries. Tek-Trol provides process measurement and control products for Flow, Level, Temperature & Pressure measurement, Control valves & Analyzer systems. We are present in 15 locations globally and are known for our knowledge, innovative solutions, reliable products and global presence.