



TEK-DP1640A

Venturi Tube

Instruction Manual

Document Number: IM-1640A

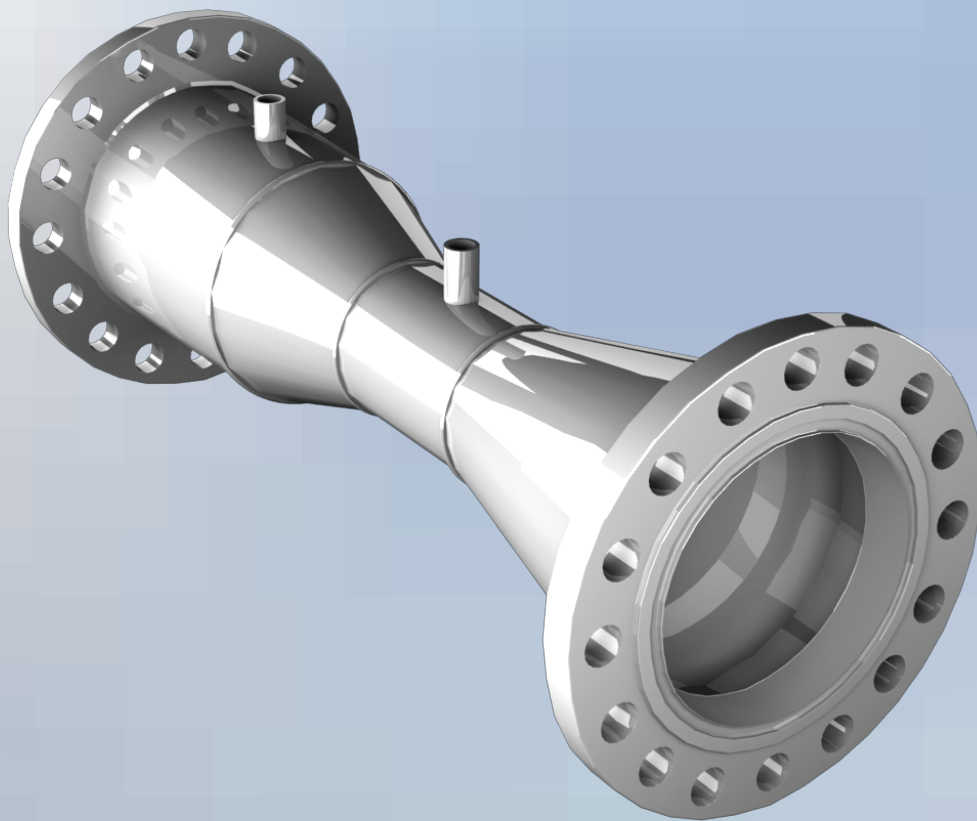

www.tek-trol.com

NOTICE

Read this manual before working with the product. For personal and system safety, and for optimum product performance, make sure you thoroughly understand the contents before installing, using, or maintaining this product.

For technical assistance, contact

Customer Support

796 Tek-Drive

Crystal Lake, IL 60014

USA

Tel: +1 847 857 6076

© **COPYRIGHT Tek-Trol LLC 2020**

No part of this publication may be copied or distributed, transmitted, transcribed, stored in a retrieval system, or translated into any human or computer language, in any form or by any means, electronic, mechanical, manual, or otherwise, or disclosed to third parties without the express written permission. The information contained in this manual is subject to change without notice.

Table of Contents

1	Safety Instructions.....	2
1.1	Intended Use	2
1.2	Certifications	2
1.3	Safety Instructions from the Manufacturer.....	2
1.3.1	Disclaimer.....	2
1.3.2	Product Liability and Warranty	2
1.3.3	Information Concerning the Documentation.....	2
1.4	Safety Precautions	2
1.5	Packaging, Transportation and Storage	3
1.5.1	Packaging.....	3
1.5.2	Transportation.....	4
1.5.3	Storage	4
1.5.4	Nameplate.....	4
2	Product Description	5
2.1	Introduction	5
2.2	Measuring Principle	5
2.3	Variants.....	6
2.3.1	Classical Venturi	6
2.3.2	Venturi Nozzle	6
2.4	Specifications	7
2.5	Meter Type.....	8
2.6	Model Chart	9
3	Installations.....	12
3.1	Mounting Options	12
3.2	Sealing Faces for Flanged Version.....	13
3.3	Pressure Tappings.....	13
3.4	Installation for Gases	14
3.4.1	Horizontal Installation Gases.....	14
3.4.2	Vertical Installation Gases	14
3.5	Installation for Liquids	15
3.5.1	Horizontal Installations Liquids	15
3.5.2	Vertical Installations Liquids.....	16
3.6	Installations for Steam	16
3.6.1	Horizontal Installation for Steam	16
3.6.2	Vertical Installation for Steam.....	17
3.7	Standard Port Location for Horizontal Installation	18
3.8	Installation for Upstream and Downstream	18
4	Maintenance	20
5	Troubleshooting	20

1 Safety Instructions

1.1 Intended Use

Tek-DP 1640A Venturi Tube is extensively used as a flow restriction in order to measure differential pressure in pipes and flow lines. This measurement is used to calculate volumetric flow.

1.2 Certifications

Tek-DP 1640A has UL, CE, NTEP, and HMO certification.

1.3 Safety Instructions from the Manufacturer

1.3.1 Disclaimer

The manufacturer will not be held accountable for any damage that happens by using its product, including, but not limited to direct, indirect, or incidental and consequential damages.

Any product purchased from the manufacturer is warranted in accordance with the relevant product documentation and our Terms and Conditions of Sale.

The manufacturer has the right to modify the content of this document, including the disclaimer, at any time for any reason without prior notice, and will not be answerable in any way for the possible consequence of such changes.

1.3.2 Product Liability and Warranty

The operator shall bear authority for the suitability of the device for the specific application. The manufacturer accepts no liability for the consequences of misuse by the operator. Wrong installation or operation of the devices (systems) will cause the warranty to be void. The respective Terms and Conditions of Sale, which forms the basis for the sales contract shall also apply.

1.3.3 Information Concerning the Documentation

To prevent any injury to the operator or damage to the device it is essential to read the information in this document and the applicable national standard safety instructions. This operating manual contain all the information that is required in various stages, such as product identification, incoming acceptance and storage, mounting, connection, operation and commissioning, troubleshooting, maintenance, and disposal.

1.4 Safety Precautions

You must read these instructions carefully prior to installing and commissioning the device. These instructions are an important part of the product and must be kept for future reference. Only by observing these instructions, optimum protection of both personnel and the environment, as well as safe and fault-free operation of the device can be ensured.

For additional information that are not discussed in this manual, contact the manufacturer.

Warnings and Symbols Used

The following safety symbol marks are used in this operation manual and on the instrument.



WARNING

Indicates a potentially hazardous situation which, if not avoided, could result in death or severe injury



CAUTION

Indicates a potentially hazardous situation which, if not avoided, may result in minor or moderate injury. It may also be used to alert against unsafe practices.



NOTE

Indicates that operating the hardware or software in this manner may damage it or lead to system failure.

1.5 Packaging, Transportation and Storage

1.5.1 Packaging

The original package consists of

- Tek-DP 1640A Venturi Tube
- Documentation



1



2

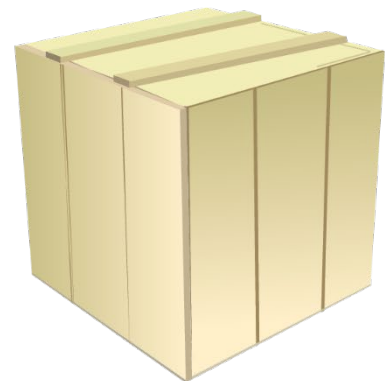

NOTE

Unpack and Check the contents for damages or sign of rough handling. Report damage to the manufacturer immediately. Check the contents against the packing list provided.

1.5.2 Transportation

- Avoid impact shocks to the device and prevent it from getting wet during transportation.
- Verify local safety regulations, directives, and company procedures with respect to hoisting, rigging, and transportation of heavy equipment.
- Transport the product to the installation site using the original manufacturer's packing whenever possible.



1.5.3 Storage

If this product is to be stored for a long period of time before installation, take the following precautions:

- Store your product in the manufacturer's original packing used for shipping.
- Storage location should conform to the following requirements:
 1. Free from rain and water
 2. Free from vibration and impact shock
 3. At room temperature with minimal temperature and humidity variation
- Properties of the instrument can change when stored outdoors.

1.5.4 Nameplate

The nameplate lists the order number and other important information, such as design details and technical data.

	
<small>www.tek-trol.com</small>	
MODEL:	1640A-50-06-H-07-C-02-C-XX-A-01-B-MTR-02C
SERIAL No.:	1640A-V20100018
PO No.:	4917
PIPE ID/SCH:	2" / SCH 40S
BETA:	0.43
PIPE MATL.:	SS304
CONE MATL.:	0.88 Inch
DESIGN PR.:	150 psi
COFF. DIS.:	0.99
<input type="radio"/> High	TAG No.: FE-30-24 
	<input type="radio"/> Low

 NOTE

Check the device nameplate to ensure that the device is delivered according to your order. Check for the correct supply voltage printed on the nameplate.

2 Product Description

2.1 Introduction

Venturi Tubes are differential pressure flow measurement devices particularly designed to measure non-viscous, clean liquids and gases. The prominent features of Venturi tubes include maximum pressure recovery, minimal upstream and downstream pipe length requirement.

Tek-DP 1640A Venturi Tubes are available in various models for normal liquid applications and wet gas applications. Tek-DP 1640A series Venturi Tubes provide consistent accuracy, maximum pressure recovery and sustained performance for various applications where permanent pressure loss is intolerable.

2.2 Measuring Principle

A Venturi Tube is nothing but a tubular section with a constriction in it. It has a convergent nozzle section towards upstream and a divergent diffuser section towards downstream which is responsible for creating a Venturi effect in the flowing fluid.

The Venturi Tube is placed inside the pipe or positioned between two flanges. It is ensured that the pipeline is completely filled with a fluid, while operating the device. A differential pressure sensor is attached between the two points, convergent and divergent sections, to determine the fluids' differential pressure.

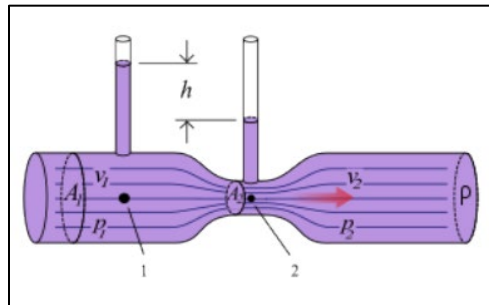

Fig 1: Venturi Tube Cross-Section

The DP sensor measures the pressure of the fluid flow, upstream and downstream. The differential pressure ($P_1 - P_2$) is proportional to the flow rate and can be determined by mathematical equations and appropriate calibration. Bernoulli described this relation between differential pressure and volumetric flow rate by a mathematical equation.

$$P_1 - P_2 = \rho/2 (V_2^2 - V_1^2)$$

①

$$Q = A_1 \sqrt{2/\rho \cdot \frac{(P_1 - P_2)}{(A_1/A_2)^2 - 1}}$$

②

$$Q_m^2 \propto \sqrt{\Delta P}$$

③

Where ρ is density of fluid.

The differential pressure generated, ΔP , is proportional to the square of mass flow rate Q_m . In simple terms, or a given size of restriction, higher the Δp , higher is the flow rate.

2.3 Variants

Tek-DP 1640A Venturi Tubes are available in various models for single phase gas, liquid applications, steam and wet gas application. The Tek-DP 1640A Venturi Tube is available in the following two configurations:

2.3.1 Classical Venturi



Fig 2: Venturi Tubes

The convergent inlet is like a truncated Venturi Tube. The Classical Venturi is used in gas and fluid flow applications, where low pressure loss is a primary requirement and can prevent sediment clogging.

2.3.2 Venturi Nozzle

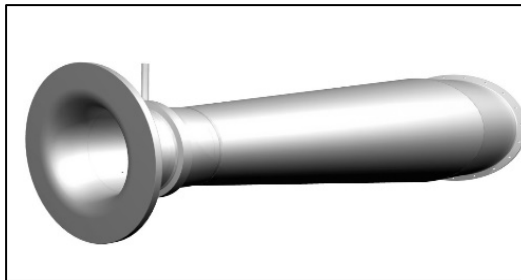

Fig 3: Venturi Nozzle

The convergent inlet matches with the structure of a flow nozzle. The Venturi nozzles are suitable in the measurement of superheated fluid, steam and gas, where the pressure gradient is below critical, and the flow pattern is steady.

2.4 Specifications

- Venturi Meter for normal Liquids

Material	All standard materials available
Tap Connections	Two ½" NPT per side standard, Flanged, socket welded, Butt welded, Valves
Venturi Tube Sizes	1" to 48", Custom size available on order, Flanged, Socket Welded, Butt Welded Valves
Turn Down Ratio	10:1 Standard
Beta Ratio	Typically, β 0.4 to 0.75
End Connection	#150 - #2500 RF/RTJ, SO/WN Flanges or Beveled ends
Operating Temperature	Standard at -20° to 100° F, optional -40° to 1200° F
Operating Position	Vertical, horizontal, (any orientations for liquids only)
Process products	Liquids, Liquid Hydrocarbons, Cryogenics
Assembly Type	Flange, Weld-In, Insertion type

- Venturi Meter for Wet Gases

Material	All standard materials available (See model chart)
Tap Connections	Three 1/2" NPT standard, Flanged end, Socket welded, Butt welded, Valves
Venturi Tube Sizes	1" to 48", Custom size available on order, Flange, Weld in, Insertion type
Turn Down Ratio	10:1 Standard
Beta Ratio	Typically, β 0.4 to 0.75
End Connection	#150 - #2500 RF/RTJ, SO/WN Flanges or Beveled ends
Operating Temperature	Standard at -20° to 100° F, optional -40° to 1200° F
Operating Position	Vertical, Horizontal, Hydrocarbon Wet Gases, Steam, (other orientations available)
Process products	Natural Gases, Steam
Assembly Type	Flange, Weld in, Insertion type

2.5 Meter Type

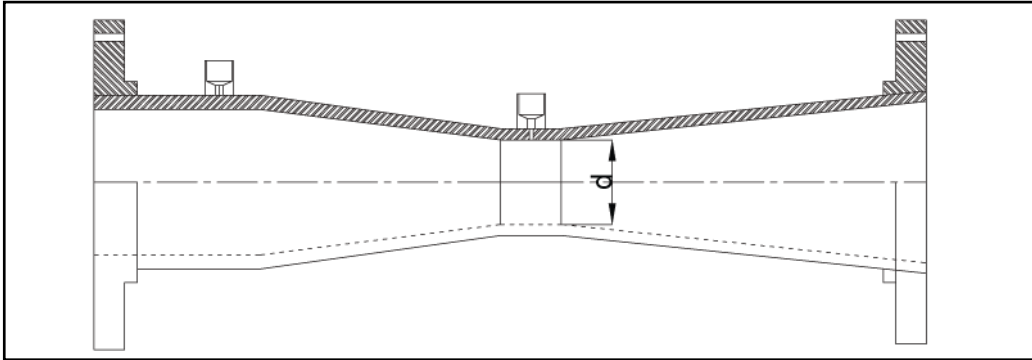

Fig 5: Flanged Type

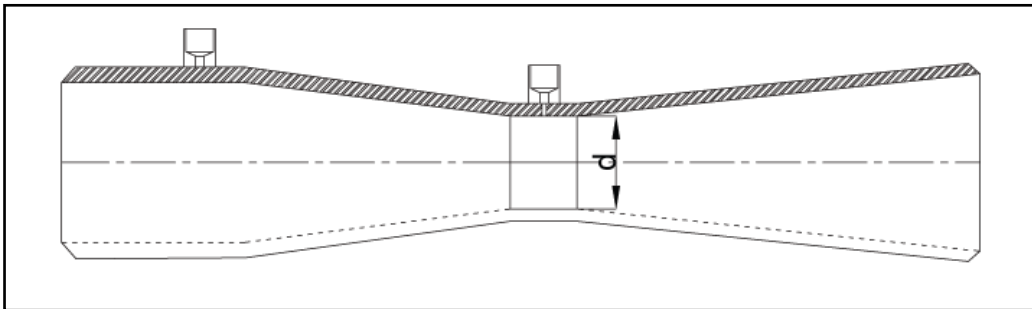

Fig 6: Weld-In Type

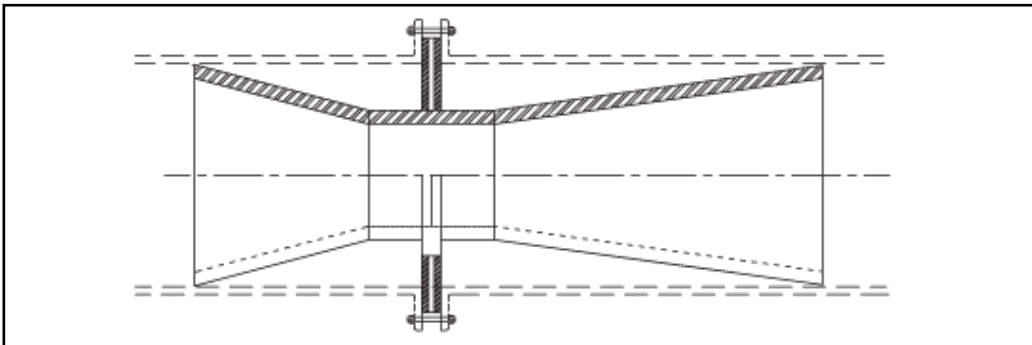

Fig 7: Insertion Type

2.6 Model Chart

Example	Tek-DP 1640A	0050	A	01	A	01	A	03	A	03	A	01	A	MTR	Tek-DP 1640A-0050-A-01-A-01-A-03-A-03-A-01-A-MTR
Series	Tek-DP 1640A														Venturi Tube
Size		0015													½"
		0020													¾"
		0025													1"
		0040													1 ½"
		0050													2"
		0065													2 ½"
		0080													3"
		0100													4"
		0150													6"
		0200													8"
		0250													10"
		0300													12"
		0350													14"
		0400													16"
		0450													18"
		0500													20"
		0600													24"
		0700													28"
		0800													32"
	0900													36"	
	1200													48"	
Meter Body			A												Carbon Steel (Standard)
			B												Low Temp CS
			C												304L SS
			D												316L SS
			E												Duplex 2205
			F												Duplex 2507
			G												Chromemoly CrMo P11
			H												Chromemoly CrMo P22
			X												Special
Pipe Schedule				01											STD (Standard Pipe SCH)
				02											10S
				03											10
				04											20
				05											30
				06											40S
				07											40
				08											80S
				09											80

				10																	120		
				11																		160	
				12																		XS	
				13																		XXS	
				XX																		Special	
Process Connection					A																	Raised Face Slip On	
					B																		Raised Face Weld Neck
					C																		RTJ Slip On
					D																		RTJ Weld Neck
					E																		Hubs
					F																		API
					G																		Beveled End
					H																		Socket
					I																		NPTF (Upto 3" Only)
					W																		Wafer Style (Upto 4" Only)
				X																		Special	
Pressure Rating						01																150#	
						02																	300#
						03																	600#
						04																	900#
						05																	1500#
						06																	2500#
						07																	NPT (3000#)
						08																	Socket
						09																	Beveled End
						XX																	Special
Throat Material of Construction								A														Carbon Steel	
								B															Low Temp CS
								C															304L SS
								D															316L SS
								E															Duplex 2205
								F															Duplex 2507
								G															Chromemoly CrMo P11
								H															Chromemoly CrMo P22
								X															Special
Pressure Taps Size								01														¼"	
								02														3/8"	
								03														½"	
								04														¾"	
								05															1"
								XX															Special
Pressure Tap Style									A													3000psi NPT	
									B													6000psi NPT	
									C													3000psi Socket	
									D													6000psi Socket	
									F														Flanged
									H														Hubs

									V							Valves
									X							Special
Beta										01						0.45
										02						0.5
										03						0.55
										04						0.6
										05						0.65
										06						0.7
										07						0.75
										XX						Special
Additional Meter Taps (D/S)											A					Nones
											B					Temperature Tap (3D)
											C					Validation/Diagnostic Tap (6D)
											X					Special
Flow Transmitters/ Computers												01				None (Customer Supplied)
												02				Tek-Bar 3110 (Liquids) - Smart DP
												03				Tek-Bar 3800 (MVT Steam & Compressed Gases)
												04				Tek-FC 8000 (Natural Gas - Flow Computer)
												05				TekValsys DPRO (Insitu Flow Validation)
												06				TekValsys DPRO WFGM (Wet Gas)
												XX				Special
Calibration													A			Dry (ISO 5167)
													B			Water
													C			Air
													D			Multiphase
													X			Special
Options														MTR		Material Test Report EN3.1
														MC		Material Cert EN2.1
														PMI		Positive Material Identification (NDE)
														COC		Certificate of Conformity
														HYD		Hydro Test
														XRT		X-Ray
														DPT		Dye Penetrant
														MPT		Magnetic Particle Testing
														O2C		O2 Cleaned
														TAG		SS TAG PLATE
														UMR		Upstream Meter Run - 1PC
														DMR		Downstream Meter Run - 1PC
													FMR		Meter Run with Flow Container Plates - 2PC	

																		CDE	Certified Drawing Electronic (As Built)
																		MRB	Manufacturing Record Book
																		DFT	Dry Film Thickness - Custom Paint Spec
																		CPC	Custom Product Code

3 Installations

This section covers instructions on installation and commissioning. Installation of the device must be carried out by trained, qualified specialists authorized to perform such works.



CAUTION

- When removing the instrument from hazardous processes, avoid direct contact with the fluid and the meter.
- All installation must comply with local installation requirements and local electrical code.

3.1 Mounting Options

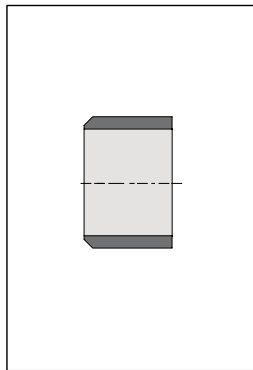

Fig 8: Butt Weld

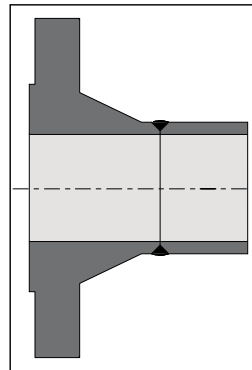

Fig 9: Welding Neck Flange

3.2 Sealing Faces for Flanged Version

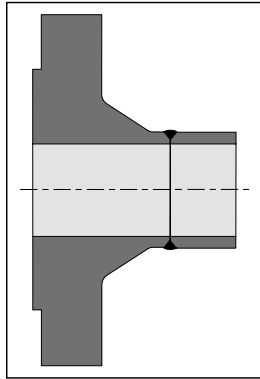

Fig 10: Raised face (RF)

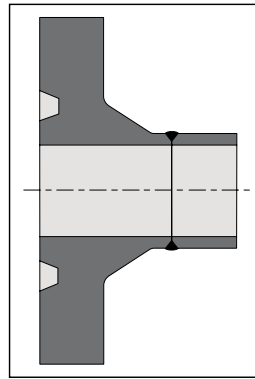

Fig 11: Ring joint (option)

3.3 Pressure Tappings

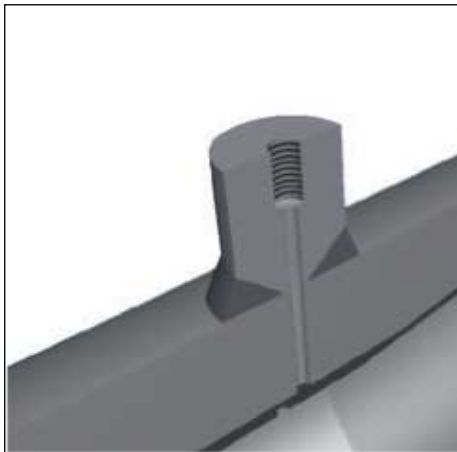

Fig 12: NPT Tap or Weld Stub

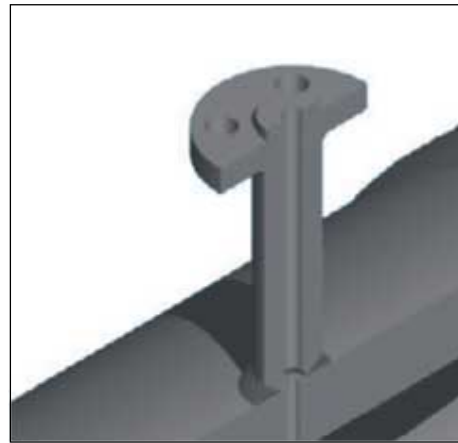

Fig 13: Tap with Flanged Ends



Fig 14: Annular Chamber Tap with Welded Ring

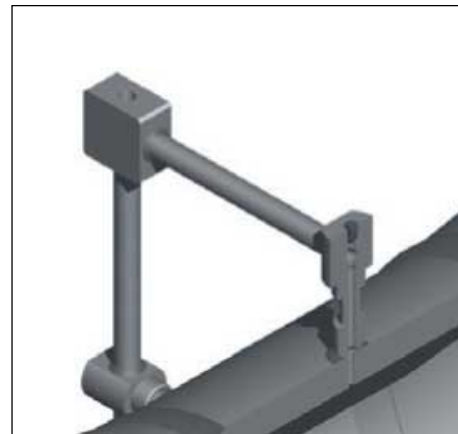

Fig 15: Annular Chamber Tap from Pipes

3.4 Installation for Gases

3.4.1 Horizontal Installation Gases

- The pressure taps on the primary device should be between the center of the horizontal line and the pipe (3 o'clock to 12 o'clock or 9 o'clock to 12 o'clock) shown in figure 16.
- The taps should be vertical to allow the liquids to drain away from the secondary device if the fluid is a "wet gas," i.e., a gas containing small quantities of liquids.
- For gases, the connecting lines from the primary device to the secondary device should be slope upwards.
- The recommended slope for self-draining is a minimum of 30°.

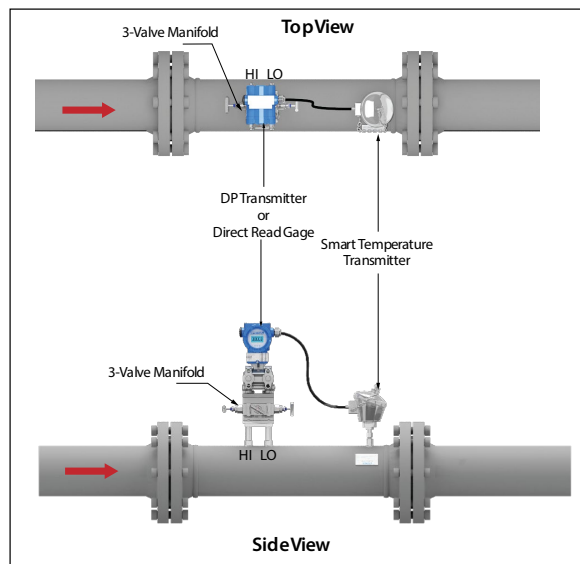

Fig 16: Horizontal Installation for Gases

3.4.2 Vertical Installation Gases

- Standard taps can be used in clean, dry, non-condensing gases, where no liquid or dirt can fill the Venturi Tube.
- The position of the transmitter is not critical.
- The transmission lines should be straight to the transmitter or horizontal and then up or down to the transmitter.

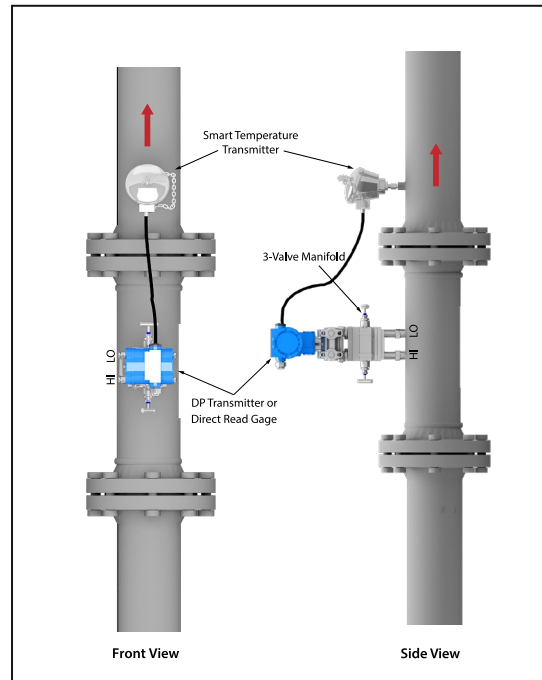

Fig 17: Vertical Installation for Gases

3.5 Installation for Liquids

3.5.1 Horizontal Installations Liquids

- The pressure taps should be between the center of the horizontal line and 60° below the centerline (3 o'clock to 5 o'clock or 7 o'clock to 9 o'clock) shown in figure 18.
- Taps at the bottom-dead-center may accumulate solids if they are present in the liquid and taps above the centerline will accumulate air or non-condensing gases.
- The taps should be more than 60° to the horizontal plane in any case.

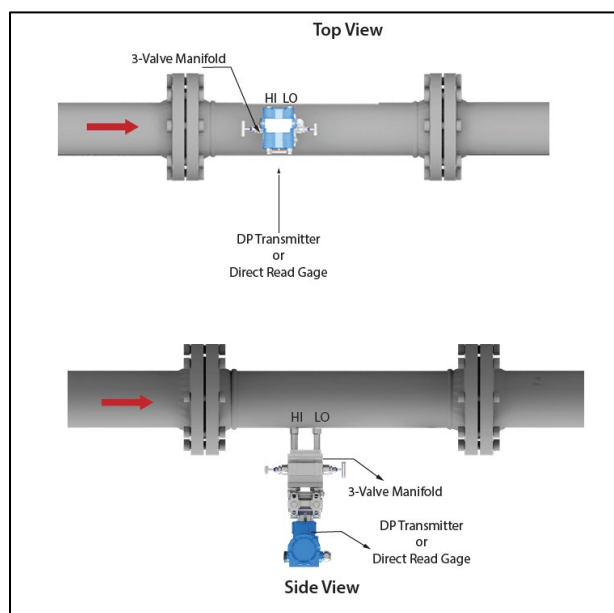

Fig 18: Horizontal Installation for Liquids

3.5.2 Vertical Installations Liquids

- In most process applications, the presumption should be made that there may be gas or vapor associated with a liquid, even though the liquid is water.
- The piping must then allow gas to rise back into the flowing medium.
- The DP piping should be carried out horizontally for a short distance and then down to the transmitter and the transmitter should be below both taps.

*Note: Wall taps must be used for dirty liquids. Standard taps should only be used on clean liquids.

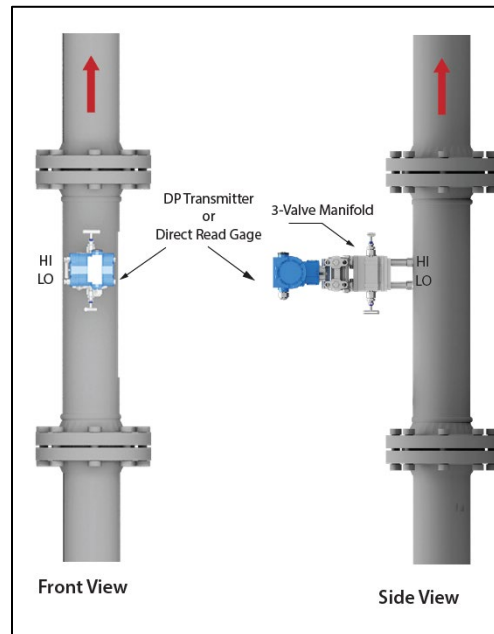

Fig 19: Vertical Installations for Liquids

3.6 Installations for Steam

3.6.1 Horizontal Installation for Steam

- Steam applications require careful consideration during installation.
- Steam at a very high temperature can damage the transmitter. Additionally, it can be in the liquid or gaseous phase, depending on temperature and pressure. Therefore, the DP pipework must be positioned in such a way that it can operate with a gas or liquid present.
- The pressure taps should be on the center of the horizontal line (3 o'clock or 9 o'clock) of the primary device. In condensing hot vapor service, such as steam, the fluid in the impulse lines is liquid condensed from the vapor. In this case, the pressure taps should be horizontal with the impulse lines and positioned to the DP transmitter, as shown in figure 20.
- There is a concern that before the lines fill with condensed liquid and cool, the secondary system will become exposed to the vapor temperature at start-up. In this case, it is wise to have a plugged tee fit in the impulse line to allow the liquid (water for steam service) to be filled with the impulse line and secondary unit before starting up (see Figure 20).
- Cryogenic (very low temperature) systems may require special designs, which are not considered here.

- The liquids in the lines will isolate the secondary device from the temperatures of the primary flowing fluid.
- Over a short distance of 100 mm (4") to 200 mm (8"), the temperature difference can be considerable.

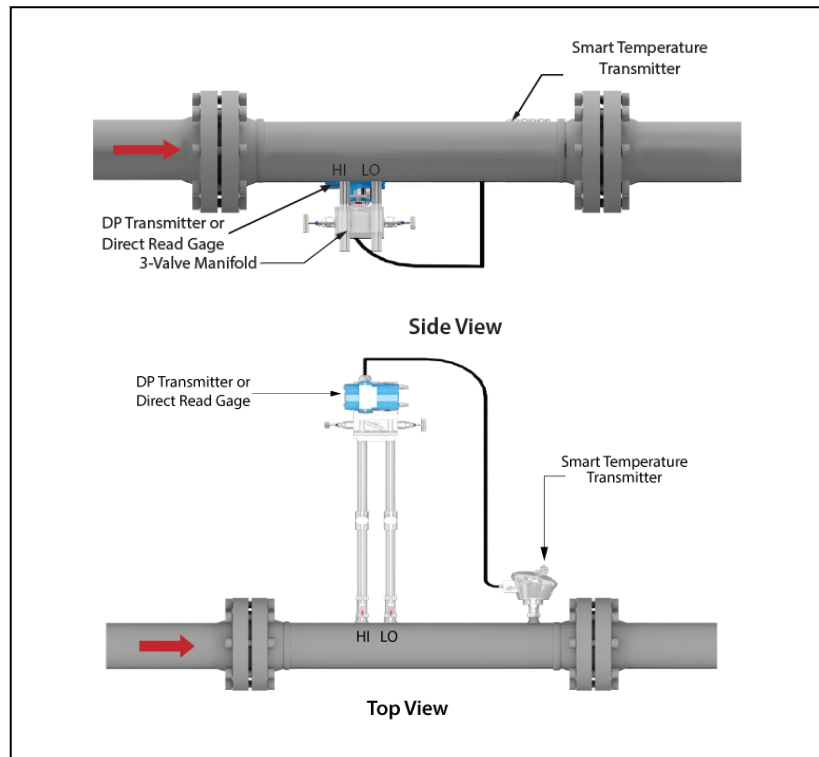

Fig 20: Horizontal Installation for Steam

3.6.2 Vertical Installation for Steam

- Wall Taps are mostly recommended for condensing vapors, preventing condensation from the buildup in the Venturi Tube or evaporating and changing the DP.
- The impulse lines are shut down horizontally to a "T" at a minimum distance of 18" for saturated and superheated steam to reduce the temperature to below the saturation temperature.
- The "T" enables a plug to be installed at the top for the liquid filling to avoid overheating of the DP cell.
- The manifold block will be placed directly below at a distance to maintain the DP transmitter at a safe operating temperature.

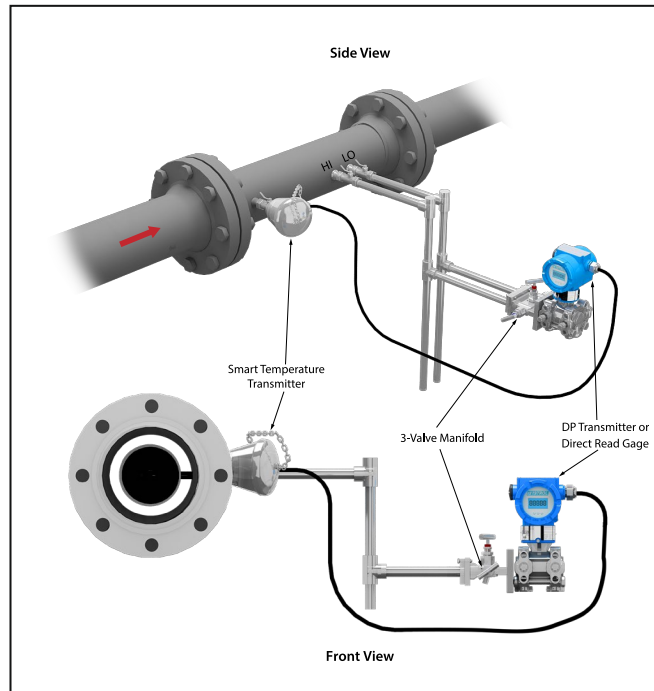

Fig 21: Vertical Installation for Steam

3.7 Standard Port Location for Horizontal Installation

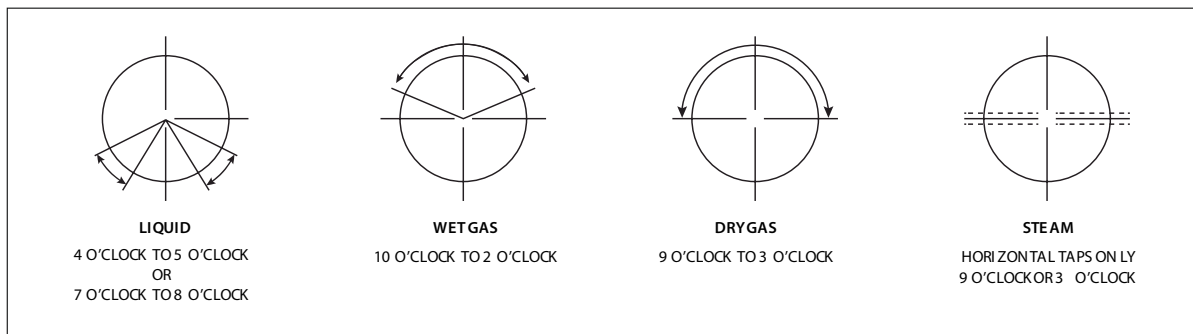

Fig 22: Standard Port Location for Horizontal Installation

3.8 Installation for Upstream and Downstream

- In most of the flow elements, the proper operation and performance depend on unrestricted upstream and downstream piping length requirements.
- The fully developed symmetrical flow profile is achieved with relatively short upstream and downstream lengths.
- Therefore, it needs minimal upstream and downstream straight pipe runs.

Note: UL= Upstream DL = Downstream 0 = NR

		0.4	0.5	0.6	0.7
 Single Elbow	UL	4	4	4	5
	DL	2	2	2	2
 Two Elbows in the Same Plane	UL	8	8	9	10
	DL	3	3	3	3
 Two Elbows in a Different Plane	UL	15	15	15	20
	DL	4	4	4	4
 Reducer	UL	6	6	6	7
	DL	2	2	2	2
 Expander	UL	8	8	8	10
	DL	3	3	3	3
 Tee Connection with Different Diameters	UL	8	8	8	10
	DL	3	3	3	3
 Globe or Gate Valve Fully Opened	UL	6	6	6	6
	DL	3	3	3	3
 Globe or Gate Valve Partially Opened	UL	12	12	14	18
	DL	3	3	3	3

4 Maintenance

- Periodic maintenance or re-calibration is unnecessary if the meter is installed correctly.
- In extreme process conditions, periodically inspect the Tek-DP 1640A Venturi Tube for any significant physical damage.
- Calibrate and maintain secondary and tertiary instruments according to the manufacturer's instructions.

5 Troubleshooting

This section provides troubleshooting techniques for most common operating problems shown in table 1.

Table 1: Troubleshooting Techniques

Symptoms	Area	Possible Problem or Solution
No Signal (0mA)	Transmitter	<ul style="list-style-type: none"> • No Power to transmitter. • Transmitter not wired correctly. • Check continuity on wiring or loose connection.
Negative Signal (<0mA)	Transmitter	<ul style="list-style-type: none"> • Transmitter wires are reversed.
Low signal (<4 mA)	Tek-DP 1640A	<ul style="list-style-type: none"> • Venturi Tube is installed backwards, with gauge lines attached as marked. • In this case, the high-pressure tap would be sensing a lower pressure than the low pressure tap. • This negative DP would force the signal below 4mA.
	Gauge Line	<ul style="list-style-type: none"> • Gauge lines are reversed. Transmitter shows more pressure on lower side than higher side. • Check "H" and "L" marks on Venturi Tube.
	Transmitter	<ul style="list-style-type: none"> • Some transmitters will send a specified mA signal when a malfunction occurs. • This can be set to low values, such as 3.8mA, or high values, such as 20.1mA.
Zero Signal (4mA)	Tek-DP 1640A	<ul style="list-style-type: none"> • Meter has been damaged. • Remove and visually inspect meter. • No flow in pipeline. • Check other system locations to verify flow through the meter. • The meter could be under pressure but still have no flow.
	Manifold	<ul style="list-style-type: none"> • Manifold / gauge lines closed or blocked. • Ensure valves and lines are open. • If fluid is safe, open vent valves on transmitter to verify pressure in the gauge lines.
	Transmitter	<ul style="list-style-type: none"> • Transmitter is in check mode. • Some transmitters allow for system checks by forcing the signal to 4 or 20mA.

		<ul style="list-style-type: none"> • Vent low side of transmitter to ensure the signal responds to pressure changes.
Wrong Signal High or Low	Tek-DP 1640A	<ul style="list-style-type: none"> • Process conditions do not match actual conditions. • Contact Tek-Trol or your sales representative to recalculate using the correct process conditions. • Wrong meter. • Verify serial numbers on meters to ensure correct specifications. • Sometimes two meters are interchanged. Remember each Venturi Tube has a unique flow coefficient.
	Gauge Lines	<ul style="list-style-type: none"> • Foreign material trapped in gauge lines. Dirt and sediment can settle into the gauge lines. If the fluid is safe, vent the gauge lines and inspect for spurts of solids, gasses, or liquids (whichever should not be there). • If the fluid is not safe, open the center manifold valve for several minutes under high DP. Close the valve and compare the signal level to before readings. • In a horizontal, liquid application, install the meter with the taps on the sides of the pipe (3 or 9 o'clock). For a horizontal, gas application, install at top or sides of the pipe (12, 3, or 9 o'clock).
	Flow Computer	<ul style="list-style-type: none"> • Flow calculations have an error. • Use loop calibrator and apply 4, 12, and 20mA to computer / system. • Each of these points should be correlate with the Venturi Tube sizing information. • Current output signal is read incorrectly. • Apply a known current to the loop and read the raw signal in the computer. • Most computers allow the user to see the mA signal directly.
Unsteady Signal	Tek-DP 1640A	<ul style="list-style-type: none"> • Partially full pipe occurring (liquids only). • Periods with a partially full pipe will cause wrong readings. See above for details.
	Transmitter	<ul style="list-style-type: none"> • Insufficient Power supply to generate signal. • Check power specifications for transmitter.
Slow response time	Transmitter	Dampening.
Sudden change in readings	Tek-DP 1640A	<ul style="list-style-type: none"> • Foreign object lodged in meter. • This will increase the restriction of the meter and raise the DP.

		<ul style="list-style-type: none"> • Remove the meter for visual inspection.
	Gauge Lines	<ul style="list-style-type: none"> • Possibility of leakage within the line.
Signal Very High	Tek-DP 1640A	<ul style="list-style-type: none"> • Meter body, near the pressure taps. • If any arrow is not visible and the meter is large than 2", the flow direction can be determined by the location of the pressure taps. • The pressure taps will be closer to the upstream side. • On meters less than 2", the gauge lines will need to be removed. Look at the base of both pressure taps. One tap will be smooth at the base, the other will be mostly weld material. • The smooth tap is on the upstream side. • Flow is going in the opposite direction from what was expected. The assumption of flow direction is sometimes wrong. • Verify with other system readings. • With a meter measuring backward flow, the DP signal will be approximately 30% high. • Partially full pipe (liquids only). A partially full pipe will cause the meter to read very high value. This can happen even in pressurized systems. <ul style="list-style-type: none"> ○ On horizontal pipes: If the fluid is safe, open a pressure tap on the top of the pipe. Air release will indicate partially full pipe. ○ On vertical pipes: Up flow will guarantee a full pipe. Down flow is difficult to diagnose if the pipe is full. • Foreign object lodged in meter. This will increase the restriction of the meter and raise the DP. Remove the meter and visually inspect.
	Gauge Lines	<ul style="list-style-type: none"> • Leak on low pressure gauge line. • Perform a leak check from the meter to the transmitter.
	Transmitter	<ul style="list-style-type: none"> • Leak on low pressure vent valve. Perform a leak check on valve. • Zero point has shifted positively. This will cause errors more pronounced at the low end of the transmitter range. • Verify by closing the manifold side valves and opening the center valve. The reading should go to zero (4mA). • Recalibrate if necessary. DP span is set very low.

		<ul style="list-style-type: none"> • Use pressure calibrator or handheld communicator to verify span point.
	Transmitter/ Flow Computer	<ul style="list-style-type: none"> • Both the transmitter and flow computer are set to take the square root of the signal. • The signal will be correct at 20mA. The positive error will increase dramatically as the signal decreases from 20mA. • Use a loop calibrator to check 12mA point.
	Flow Computer	<ul style="list-style-type: none"> • 4mA set to minimum flow. • Our calculations assume that 4 mA will be equal to zero flow. Sometimes 4 mA is set to equal the minimum flow on the sizing page. • This error will be zero at maximum flow and increase as the flow decreases. • The amount of error will depend on the zero offset.
Signal Very Low	Manifold	<ul style="list-style-type: none"> • Manifold is cross-vented. The center valve must be closed. • To test, close the two side valves and watch the transmitter signal. • If the signal goes to zero (4mA), the center valve is not closed completely.
	Gauge lines	<ul style="list-style-type: none"> • Leak on high pressure gauge line. • Perform a leak check from the meter to the transmitter.
	Transmitter	<ul style="list-style-type: none"> • Perform a leak check on valve to identify leak on high pressure vent valve. • Zero point when shifted negatively will cause errors more pronounced at the low end of the transmitter range. Verify by closing the manifold side valves and open the center valve. The reading should go to zero (4mA). Recalibrate if necessary. • Transmitter DP span is set too high hence use pressure calibrator or handheld communicator to verify span point.
	Transmitter/ Flow Computer	<ul style="list-style-type: none"> • Neither the transmitter nor flow computer is set to take the square root of the signal. The signal will be correct at 20mA. • The negative error will increase dramatically as the signal decreases from 20mA. • Use a loop calibrator to check 12mA point.



TEKMATION LLC reserves the right to change the designs and/or materials of its products without notice. The contents of this publication are the property of TEKMATON LLC and cannot be reproduced by any other party without written permission. All rights reserved. Copyright © 2015 TEKMATON LLC
DOCTEK/TIPS/ANL/210520/16004/03.1
TEKMATION LLC



www.tek-trol.com

Tek-Trol is a fully owned subsidiary of TEKMATON LLC. We offer our customers a comprehensive range of products and solutions for process, power and oil & gas industries. Tek-Trol provides process measurement and control products for Flow, Level, Temperature & Pressure Measurement, Control Valves & Analyzer systems. We are present in 15 locations globally and are known for our knowledge, innovative solutions, reliable products and global presence.

Tek-Trol LLC

796 Tek Drive Crystal Lake,
IL 60014, USA

 +1 847-857-6076

 tektrol@tek-trol.com

 www.tek-trol.com

Flow | Level | Temperature | Pressure | Valves | Analyzers | Accessories | TekValSys