



Technology Solutions

TEK-DP 1670A

*Segmental Wedge
Differential Pressure Flow Meters*

Instruction Manual

Document Number: IM-1670A

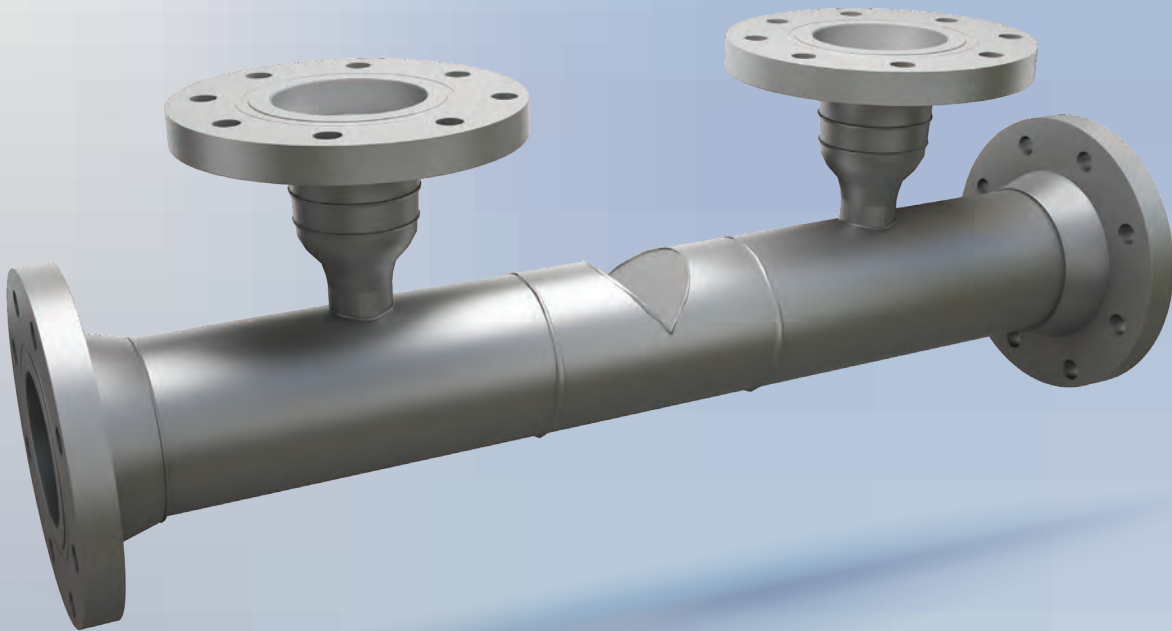

www.tek-trol.com

NOTICE

Read this manual before working with the product. For personal and system safety, and for optimum product performance, make sure you thoroughly understand the contents before installing, using, or maintaining this product.

For technical assistance, contact

Customer Support

796 Tek-Drive

Crystal Lake, IL 60014

USA

Tel: +1 847 857 6076

© **COPYRIGHT Tek-Trol LLC 2021**

No part of this publication may be copied or distributed, transmitted, transcribed, stored in a retrieval system, or translated into any human or computer language, in any form or by any means, electronic, mechanical, manual, or otherwise, or disclosed to third parties without the express written permission. The information contained in this manual is subject to change without notice.

Table of Contents

1	Safety Instructions.....	2
1.1	Intended Use	2
1.2	Certifications	2
1.3	Safety Instructions from the Manufacturer	2
1.3.1	Disclaimer.....	2
1.3.2	Product Liability and Warranty	2
1.3.3	Information Concerning the Documentation.....	2
1.4	Safety Precautions	2
1.5	Packaging, Transportation and Storage	3
1.5.1	Packaging.....	3
1.5.2	Transportation.....	3
1.5.3	Storage	3
1.5.4	Nameplate.....	4
2	Product Description	5
2.1	Introduction	5
2.2	Measuring Principle	5
2.3	Comparison between Venturi, Orifice, Cone and Segmental Wedge DP Flow Meters	6
2.4	Main Meter Components and Usage of Tek-DP 1670A	6
2.5	Specifications	6
2.6	Segmental Wedge Flow Meter Designs.....	7
2.7	Dimensional Drawings	7
2.8	Model Charts.....	9
3	Installations.....	11
3.1	General Instructions	12
3.2	Mounting Location Selection.....	12
3.3	Straight Pipe Run Requirements.....	13
3.4	Installation and Differential Pressure Connections.....	13
3.4.1	General Instructions.....	13
3.4.2	Line Installation	14
3.4.3	Differential Pressure Connections.....	14
3.4.4	Pipe Connections.....	14
4	Maintenance	15
4.1	Removal of Segmental Wedge Flow Meter	15
4.2	Inspection	15
5	Troubleshooting	15

1 Safety Instructions

1.1 Intended Use

Tek-DP 1670A Segmental Wedge Flow Meter measures low, highly viscous flows, dirty or corrosive gas or liquid flows, and hot or cold flows, with a small pressure loss.

1.2 Certifications

ASME B31.1, ISO 16528, BS-7045 Compliance.

1.3 Safety Instructions from the Manufacturer

1.3.1 Disclaimer

The manufacturer will not be held accountable for any damage that happens by using its product, including, but not limited to direct, indirect, or incidental and consequential damages.

Any product purchased from the manufacturer is warranted in accordance with the relevant product documentation and our Terms and Conditions of Sale.

The manufacturer has the right to modify the content of this document, including the disclaimer, at any time for any reason without prior notice, and will not be answerable in any way for the possible consequence of such changes.

1.3.2 Product Liability and Warranty

The operator shall bear authority for the suitability of the device for the specific application. The manufacturer accepts no liability for the consequences of misuse by the operator. Wrong installation or operation of the devices (systems) will cause the warranty to be void. The respective Terms and Conditions of Sale, which forms the basis for the sales contract shall also apply.

1.3.3 Information Concerning the Documentation

To prevent any injury to the operator or damage to the device it is essential to read the information in this document and the applicable national standard safety instructions. This operating manual contain all the information that is required in various stages, such as product identification, incoming acceptance and storage, mounting, connection, operation and commissioning, troubleshooting, maintenance, and disposal.

1.4 Safety Precautions

You must read these instructions carefully prior to installing and commissioning the device. These instructions are an important part of the product and must be kept for future reference. Only by observing these instructions, optimum protection of both personnel and the environment, as well as safe and fault-free operation of the device can be ensured.

For additional information that are not discussed in this manual, contact the manufacturer.

Warnings and Symbols Used

The following safety symbol marks are used in this operation manual and on the instrument.



WARNING

Indicates a potentially hazardous situation which, if not avoided, could result in death or severe injury



CAUTION

Indicates a potentially hazardous situation which, if not avoided, may result in minor or moderate injury. It may also be used to alert against unsafe practices.



NOTE

Indicates that operating the hardware or software in this manner may damage it or lead to system failure.

1.5 Packaging, Transportation and Storage

1.5.1 Packaging

The original package consists of

1. Tek-DP 1670A Segmental Wedge Flow Meters
2. Documentation Package NDT and Materials Certificates



NOTE

Unpack and check the contents for damages or sign of rough handling. Report damage to the manufacturer immediately. Check the contents against the packing list provided.

1.5.2 Transportation

- Avoid impact shocks to the device and prevent it from getting wet during transportation.
- Verify local safety regulations, directives, and company procedures with respect to hoisting, rigging, and transportation of heavy equipment.
- Transport the product to the installation site using the original manufacturer's packing whenever possible.

1.5.3 Storage

If this product is to be stored for a long period of time before installation, take the following precautions:

- Store your product in the manufacturer's original packing used for shipping.
- Storage location should conform to the following requirements:
 1. Free from rain and water ingress

2. Free from vibration and impact shock
 3. At room temperature with minimal temperature and humidity variation
- Properties of the instrument can change when stored outdoors (carbon steels).

1.5.4 Nameplate

The nameplate lists the order number and other important information, such as design details and technical data.



NOTE

Check the device nameplate to ensure that the device is delivered according to your order. Check for the correct Beta Ratio, Pipe ID, and TAG number if printed on the nameplate. Flow Meter Coefficient of discharge (C_d) is shown on the materials certification / documentation for entry into a flow computer

2 Product Description

2.1 Introduction

Tek-DP 1670A Segmental Wedge Flow Meters have no moving parts, making them virtually maintenance-free. They generally give repeatable readings in process flow applications. Therefore, Tek-DP 1670A Segmental Wedge Flow Meters can handle low flows using accurate transmitters, highly viscous flows, dirty or corrosive gas or liquid flows, and hot or cold flows with a small pressure loss. The Tek-DP 1670A Segmental Wedge Flow Meter provides bi-directional flow measurement. The welded construction and wide range of materials ensure a reliable and robust measurement under extreme pressure and temperature conditions or aggressive media. The Tek-DP 1670A Segmental Wedge Flow Meters design delivers a significant cost savings benefit since the profile is virtually immune to any wear or erosion, requiring very little maintenance and inspection.

2.2 Measuring Principle

The Segmental Wedge Flow Meter consists of a measurement pipe with pressure taps in front and behind a Differential Pressure (ΔP) flow element (restriction), which has a wedge shape. The restriction is welded into the measurement pipe section between the top taps, as shown in Figure 1.

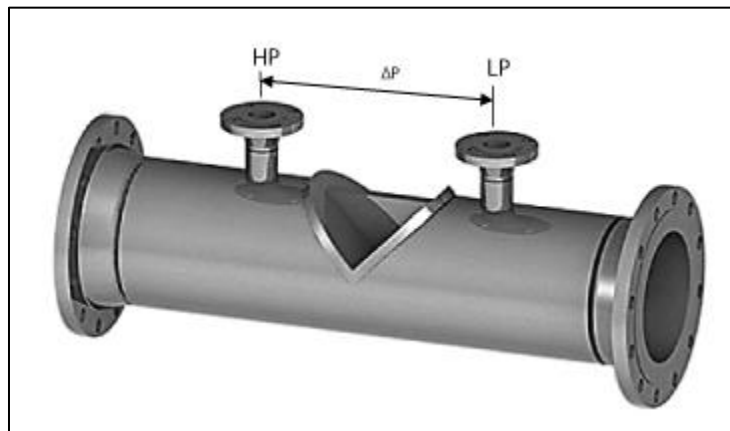

Fig 1: Tek-DP 1670A Standard Design

The static pressure is measured in front of the Segmental Wedge Flow Meter (high side) and behind the Segmental Wedge Flow Meter, the low-pressure differential is taken (a low-pressure side).

Tek-DP 1670A Segmental Wedge Flow Meters usually have a (coefficient of discharge) C.d. = 0.79 approximately, which can be further defined from external calibration.

Venturi, Orifice and DP Cone Meter have a throat with a low-pressure tapping located at the maximum velocity area. A Segmental Wedge Flow Meter consists of the low-pressure tapping in the pipe wall, not in a throat.

They have been used with other DP meter types as part of a multiphase/wet gas meter. While the meter is not fiscal, it can be used for slurries and areas where high contamination and particulates are in the fluid stream.

2.3 Comparison between Venturi, Orifice, Cone and Segmental Wedge DP Flow Meters

The Venturi, Orifice, Cone and Segmental Wedge Flow Meters are all geometrically different and it is not intuitively obvious how to compare them. The typical discharge coefficients (C.d.) versus beta ratios for all the major types of meters are shown in comparison with a Segmental Wedge Flow Meter data shown in Figure 2.

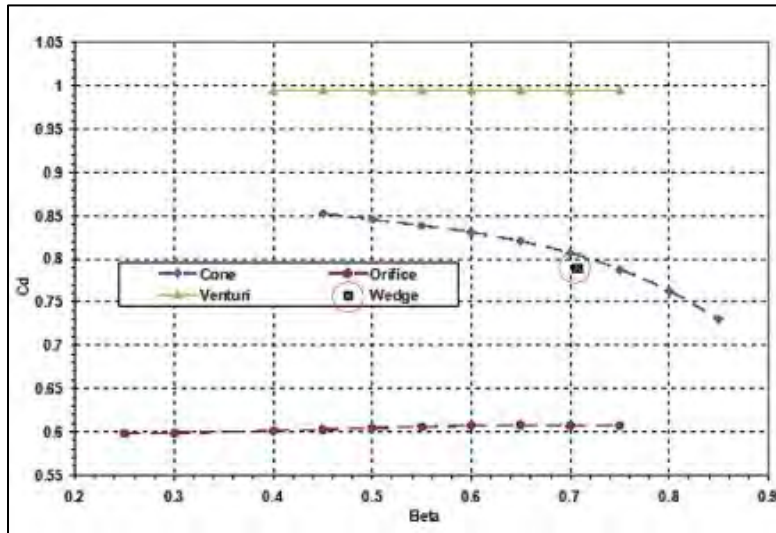

Figure 2: Typical DP Family Meter Discharge Coefficients (per beta ratio)

2.4 Main Meter Components and Usage of Tek-DP 1670A

Tek-DP 1670A Quality Segmental Wedge Flow Meters can also be wet calibrated for the process application's flow range to provide a $\pm 0.5\%$ coefficient of discharge accuracy over the calibrated range. They are designed to measure a full pipe, highly viscous, particulate-laden flows. Typical applications include slurries, asphalt, chlorine, gas, steam (Certain defined applications), or air-entrained liquids.

Materials of construction can be varied design can be produced using any weldable materials depending upon the particular demands of the application. Currently, available manufacturing materials are Carbon Steel, 316 & 316L Stainless Steel, 304 & 304L Stainless Steel, Duplex and Super Duplex Steels, Hastelloy and Monel. All applicable pressure vessel codes and standards are considered, such as:

- Boiler and Pressure Vessel Code
- ASME B31.1 and B31.3 for ASME fluid meters
- MFC-3M-1985, ISO 16528, BS-7045 compliance if required.

Designed for use with Raised Face, Flat Face, Weld End, Ring Joint Flanges of any flange rating of either U.S. or overseas standards.

2.5 Specifications

Accuracy	$\pm 0.5\%$ of the coefficient of discharge accuracy over calibrated Reynolds Number (Wet calibration at approved laboratory); $\pm 5.0\%$ of actual flow rate (dry calibration based on geometry only)
Repeatability	$\pm 0.2\%$
Line Size	1" to 24" Nominal Diameter
End Connections	Flange ends, weld end, slip-on, RTJ joint, butt end

Fluid Capability	Gas or liquid – Pipe running full
Temperature	Dependent upon wetted material and gasket materials being used
Pressure	Maximum working pressure is per ANSI B16.5 standards
Material	Carbon Steel, 316 SS, 316L SS, 304 SS, Super Duplex Steel, Hastelloy and Monel
Pipe Reynolds Number (ReD) Capability	Relatively low pipe Reynolds Numbers can be addressed with fair accuracy, the discharge coefficient being generally stable through the confirmed application ranges, Bi-directional usage is permitted using applicable pressure / differential pressure transmitters
Standards	ASME B31.1 and B31.3

2.6 Segmental Wedge Flow Meter Designs

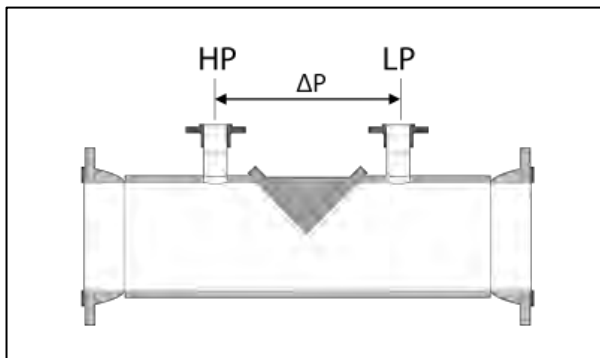

Fig 3: Flanged Hub

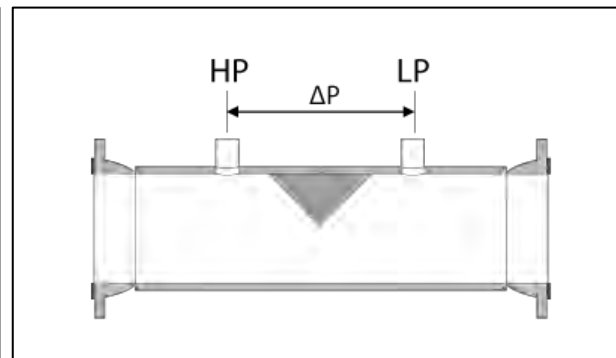

Fig 4: Threaded Taps

2.7 Dimensional Drawings

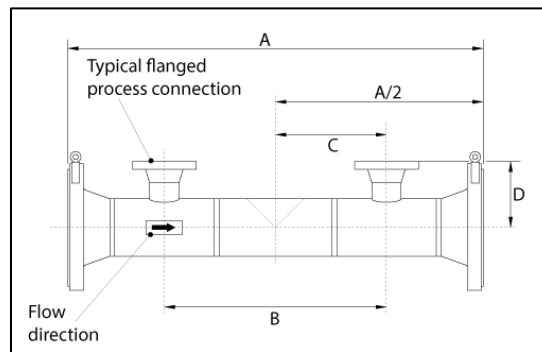

Fig 5: Tek-DP 1670A With Flanged Tapping's and RFWN End Flanges (1 ½", 2 and 3")

*Note: Flow direction may be Bi -Directional.

Size in (mm)	A ± ¼" (±4.58mm) in (mm)			B in (mm)	C in (mm)	D in (mm)			Approximate Weight kg (lbs.)		
	Flange Rating					Flange Rating			Flange Rating		
	150	300	600			150	300	600	150	300	600
1 ½" (40)	21 ¼" (530)	21 ¾" (543)	22 ¼" (559)	11 ¾" (292)	5 ¾" (146)	8 ¾" (207)	8 ½" (214)	8 ½" (212)	25 (55)	28 (61)	32 (71)
2" (50)	21 ¾" (546)	22 ¼" (559)	23" (575)	11 ¾" (292)	5 ¾" (146)	8 ¾" (216)	8 ¾" (222)	9 ¼" (231)	28 (62)	32 (70)	38 (84)
3" (80)	25 ¾" (645)	25 ¾" (641)	26 ½" (660)	12 ½" (311)	6 ¾" (155)	6 ¾" (155)	6 ¾" (166)	7" (175)	35 (78)	42 (92)	46 (102)

*Note: Slip on, full face and RTJ flange connection are also available. Contact Tek-Trol for length details.

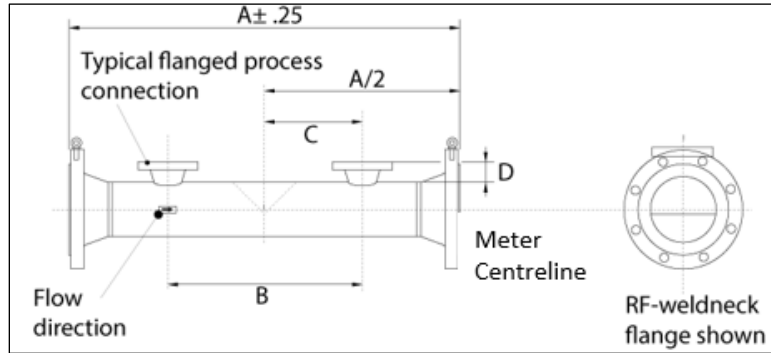

Fig 6: Tek-DP 1670A With Flanged Tapping's and RFWN End Flanges (4" to 24")

*Note: Flow direction may be Bi -Directional.

Size in (mm)	A ± ¼" (±4.58mm) in (mm)			B in (mm)	C in (mm)	D in (mm)			Approximate Weight kg (lbs.)		
	Flange Rating					Flange Rating			Flange Rating		
	150	300	600			150	300	600	150	300	600
4"(100)	36"(900)	36 ¾"(920)	39 ½"(990)	15 ¼"(381)	7 ½"(190)	2 ¾"(70)	3"(80)	3 ½"(89)	61 (135)	68 (150)	79 (175)
6"(150)	41"(1028)	42"(1047)	44"(1100)	18 ¼"(457)	9"(225)	2 ¾"(70)	3"(80)	3 ½"(89)	73 (160)	95 (210)	122 (270)
8"(200)	43 ¾"(1092)	44 ½"(1111)	46 ¾"(1168)	20 ¾"(521)	10 ½"(260)	2 ¾"(70)	3"(80)	3 ½"(89)	95 (210)	120 (265)	166 (365)
10"(250)	45 ¾"(1143)	47"(1175)	50 ¼"(1257)	24"(600)	12"(300)	2 ¾"(70)	3"(80)	3 ½"(89)	122 (270)	156 (345)	238 (525)
12"(300)	52 ¾"(1321)	54"(1350)	56 ¾"(1416)	27"(675)	13 ½"(336)	2 ¾"(70)	3"(80)	3 ½"(89)	159 (350)	181 (400)	
14"(350)	56"(1400)	57"(1425)	59 ½"(1485)	29 ½"(736)	14 ½"(356)	2 ¾"(70)	3"(80)	3 ½"(89)	186 (410)	277 (610)	
16"(400)	59"(1475)	60 ½"(1511)	63 ½"(1587)	31"(775)	15 ½"(387)	2 ¾"(70)	3"(80)	3 ½"(89)	227 (500)	342 (755)	
18"(450)	63"(1574)	64 ½"(1613)	67"(1675)	34"(850)	16 ½"(413)	2 ¾"(70)	3"(80)	3 ½"(89)	227 (500)	395 (870)	
20"(500)	67 ½"(1686)	68 ¾"(1720)	71 ½"(1790)	37 ½"(940)	18 ¾"(470)	2 ¾"(70)	3"(80)	3 ½"(89)	318 (700)	499 (1100)	
24"(600)	74 ¼"(1854)	75 ½"(1886)	78 ¾"(1968)	42 ¾"(1066)	21 ¼"(533)	2 ¾"(70)	3"(80)	3 ½"(89)	433 (955)	594 (1310)	

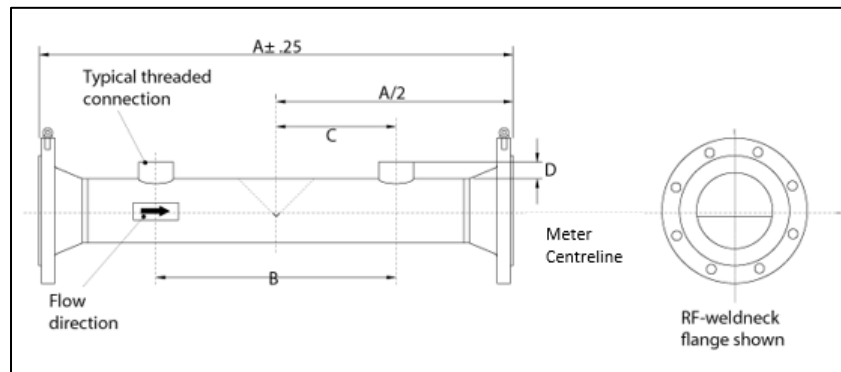

Fig 7: Tek-DP 1670A with Threaded Connection

*Note: Flow direction may be Bi -Directional.

Size in (mm)	A ± ¼" (±4.58mm) in (mm)			B in (mm)	C in (mm)	D in (mm)	Approximate Weight kg (lbs.)		
	Flange Rating						Flange Rating		
	150	300	600				150	300	600
8"(200)	43 ¾"(1092)	44 ½"(1111)	46 ¾"(1168)	20 ¾"(520)	10 ½"(260)	1"(25)	52 (115)	79 (175)	129 (285)
10"(250)	45 ¾"(1143)	47"(1175)	50 ¼"(1257)	24"(600)	12"(300)	1"(25)	75 (165)	127 (280)	204 (450)
12"(300)	52 ¾"(1320)	54"(1350)	56 ¾"(1416)	27"(675)	13 ½"(336)	1"(25)	107 (235)	172 (380)	
14"(350)	56"(1400)	57"(1425)	59 ½"(1485)	29 ½"(736)	14 ½"(356)	1"(25)	140 (310)	283 (625)	
16"(400)	59"(1475)	60 ½"(1511)	63 ½"(1587)	31"(775)	15 ½"(387)	1"(25)	186 (410)	290 (640)	
18"(450)	63"(1575)	64 ½"(1612)	67"(1675)	34"(850)	17"(425)	1"(25)	226 (500)	367 (810)	
20"(500)	67"(1675)	68 ¾"(1720)	71 ½"(1790)	37 ½"(940)	18 ¾"(470)	1"(25)	286 (630)	455 (1005)	
24"(600)	74 ¼"(1854)	75 ½"(1886)	78 ¾"(1968)	42 ¾"(1066)	21 ¼"(533)	1"(25)	394 (870)	539 (1190)	

*Note: Dimensions are subject to vary at time of manufacturing based on final Beta selected. Dimensional drawing with a final engineering sizing sheet will be provided within 1-2 weeks of order acceptance.

2.8 Model Charts

Example	Tek-DP 1670A	0050	A	01	A	01	W0	A	00	03	01	A	MTR	Tek-DP 1670A-0050-A-01-A-01-W0-A--00-03- 01-A-MTR
Series	Tek-DP 1670A													Segmental Wedge Flow Meter
Size		0025 0050 0065 0080 0100 0150 0200 0250 0300 0350 0400 0450 0500 0600												1" 2" 2 ½" 3" 4" 6" 8" 10" 12" 14" 16" 18" 20" 24"
Meter Body			A B C D E F G H I X											Carbon Steel (Standard) Low Temp CS 304L SS 316L SS Duplex 2205 Duplex 2507 Chromemoly CrMo P11 Chromemoly CrMo P22 Inconel Cladding Special
Pipe Schedule				01 02 03 04 05 06 07 08 09 10 11 12 13 XX										Standard (Tek-Trol's Standard) 10S 10 20 30 40S 40 80S 80 120 160 Extra Strong XX Strong Special
Process Connection					A B C D E									RF Slip On RF Weld Neck RTJ Slip On RTJ Weld Neck Hubs

						F G H I W U X												API Beveled End Socket NPTF (Up to 3" Only) Wafer Style (Up to 4" Only) Union Special	
Pressure Rating																			150# 300# 600# 900# 1500# 2500# 3000# (NPT) 10K(API/Hubs) 15K (API/Hubs) Special
Wedges Type																			Flanged Hub (Used for Liquids) Threaded Taps (Used for Gases) Special
Wedges Material of Construction																			Carbon Steel Low Temp CS 304L SS (Standard Option) 316L SS Duplex 2205 Duplex 2507 Chromemoly CrMo P11 Chromemoly CrMo P22 Inconel Cladding Special
Tap Location																			Standard Pipe Taps Special
Beta																			0.45 0.5 0.55 0.6 0.65 0.7 0.75 Special
Flow Transmitters / Computers																			None (Customer Supplied) Tek-Bar 3110 (Liquids) - Smart DP Tek-Bar 3800 (MVT Steam and Compressed Gases) Tek-FC 8000 (Natural Gas - Flow Computer) TekValsys DPRO (Insitu Flow Validation) TekValsys DPRO WFGM (Wet Gas)

																			XX		Special			
Calibration																					A	Dry (ISO 5167)		
																					B	Water		
																					C	Air		
																					D	Multiphase		
																					X	Special		
Options																						MTR	Material Test Report EN3.1	
																						MC	Material Cert EN2.1	
																						PMI	Positive Material Identification (NDE)	
																						COC	Certificate of Conformity	
																						HYD	Hydro Test	
																							XRT	X-Ray
																							DPT	Dye Penetrant
																							MPT	Magnetic Particle Testing
																							O2C	O2 Cleaned
																							TAG	SS TAG PLATE
																							UMR	Upstream Meter Run - 1PC
																							DMR	Downstream Meter Run - 1PC
																							FMR	Meter Run with Flow Conditioner Plates - 2PC
																						CDE	Certified Drawing Electronic (As Built)	
																						MRB	Manufacturing Record Book	
																						DFT	Dry Film Thickness - Custom Paint Spec	
																						CPC	Custom Product Code	

3 Installations

This section covers instructions on installation and commissioning. Installation of the device must be carried out by qualified trained, specialists authorized to perform such works.



CAUTION

- When removing the instrument from hazardous processes, avoid direct contact with the fluid and the meter.
- All installations must comply with local installation requirements and local electrical code.



WARNING

- Never exceed the maximum rated pressure or temperature of the flow element.
- Process pressure and/or process materials remaining in flow elements can cause injury do not open any pressure-retaining parts under line pressure.
- Standard plant safety procedures should be followed when removing elements from service.
- Qualified technicians must perform maintenance.
- Disconnect all power sources to avoid electrical shock when servicing DP/Pressure Transmitters etc.

3.1 General Instructions

- The Tek-DP 1670A Segmental Wedge Flow Meter is a process quality flow meter. It must be sized appropriately to suit the end-user process conditions and installed correctly to ensure stated accuracy and proper operation.
- If the meter is damaged during installation, it must be replaced.
- Pressure Taps should be horizontally oriented. This will help to ensure that air bubbles or sedimentation do not accumulate in the pressure tap connections.
- Should review the space around the meter practical for the installation, inspection and maintenance.
- Flange bolts and nuts (where needed) should be tightened according to specific industry flange assembly standards, adequate to prevent leakage from the connections using applicable gaskets.
- Installation tolerances should be within industry standards for installation.

3.2 Mounting Location Selection

- Generally, the horizontal orientation of the flow element with the impulse tap positioning situated between 45 to 90 degrees from a vertical centerline of the impulse tap component(s) is recommended. This method of horizontal mounting allows for free passage of most solids and helps to eliminate air entrapment at the transmitter connection in liquid operation. See Figure 8.
- Other positions are acceptable provided proper venting of the transmitter sensing lines is accomplished. The differences between sensing line elevations shall also be considered. Tap position locations are suggested to be below the pipe centerline for clean liquid service.
- Service taps must be positioned such that all are self-draining for dirty liquid service (for ex., triple taps units will be at the 3, 9, and 12 o'clock position).
- Dirty liquid service can be any process where the fluid may settle, cake, or be set up within the tap chambers. Examples of dirty liquid services are waste streams, coke slurries, black liquor, fluids with high particulates, etc.
- As shown in Figure 9, vertical installations may introduce a slight hydrostatic head effect that must be considered when zeroing the transmitter.
- Please Note: Laboratory flow calibration for Coefficient of discharge (C_d) development per field installation geometry is recommended for applications where installed accuracy is critical. This service is optional but can be provided at an additional cost.

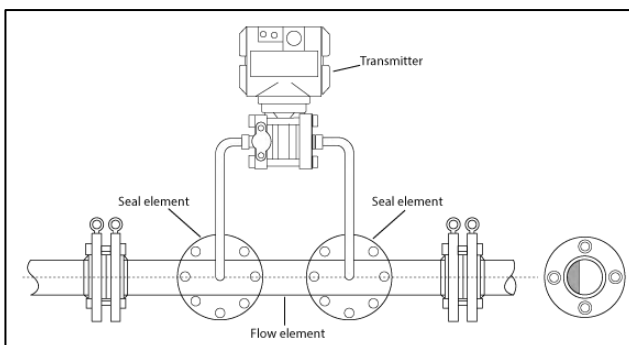

Fig 8: Horizontal Installation

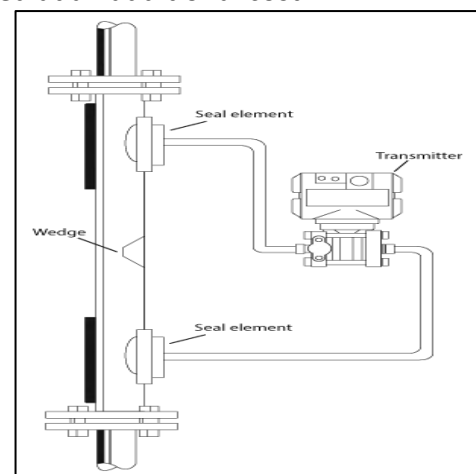

Fig 9: Vertical Installation

3.3 Straight Pipe Run Requirements

- As with most flow elements, proper operation and performance are dependent on the required lengths of available upstream and downstream piping.
- The recommended minimum length of the upstream side of the Segmental Wedge Flow Meter depends on the fittings at the end of the straight runs and respective pipe configuration.
- Minimum upstream and downstream lengths are as follows:
 - Upstream requirements as a general rule: 10 nominal pipe diameters.
 - Downstream requirements as a general rule: 2 nominal pipe diameters.

Table 1: Minimum upstream and downstream lengths

Fittings	Recommended		Minimum	
	Upstream	Downstream	Upstream	Downstream
3 Elbows close coupled	15D	5D	15D	3D
2 Elbows close coupled out of plane	10D	5D	10D	3D
2 Elbows close coupled in plane	10D	5D	5D	3D
1 Elbow	10D	5D	5D	3D
Tee-bull plugged	10D	5D	5D	3D
Tee-run plugged	10D	5D	5D	3D
Tee-flow in bull and run	10D	5D	5D	3D
Y-run plugged	10D	5D	5D	3D
Concentric reducer	10D	5D	5D	3D
Concentric expander	10D	5D	5D	3D
Partially open gate valve	10D	5D	10D	3D

3.4 Installation and Differential Pressure Connections



WARNING

Never exceed the maximum pressure or temperature for the process being measured. Exceeding maximum pressure or temperature ratings can lead to personal injury or equipment damage. The process piping flanges for installation must be identical to the serial number on the data plate. The process temperature and pressure must never exceed the ratings for the element stamped on the data plate.

3.4.1 General Instructions

- Before installation of any Segmental Wedge Flow Meter, inspect for damage, particularly at sealing surfaces.
- Any damage must be reported as soon as possible.
- Check the data plate to ensure the stamped ratings match the process conditions of the pipeline in which it is to be installed.
- Each flow element has a data plate attached with an arrow indicating the required direction of flow.

- Failure to correctly orientate the Segmental Wedge Flow Meter to the direction of flow may result in improper results when using data supplied for an element that has been calibrated.

3.4.2 Line Installation

- All Segmental Wedge Flow Meter require a gasket between the process line connection and the mating flange.
- Select gaskets that will withstand the maximum process temperature and pressure, which resist the corrosive attack of the process itself.
- The pipeline flanges must be suitable for the temperature and pressure of the measured process to provide a safe installation.
- When completing the bolting process, ensure the gaskets are correctly centered on minimizing protrusion into the pipe opening.
- Misalignment may cause added flow turbulence. However, performance affects are typically minimal depending upon the application.
- Bolt the element in line with suitable hardware using recommended bolt torques for the type and class rating of the flanges.

3.4.3 Differential Pressure Connections

- The high-pressure connection is always on the upstream side of the flow direction arrow and the low-pressure connection on the downstream side.
- Fittings used must be able to withstand the process temperature and pressure conditions and provide adequate corrosion resistance.
- Refer to the appropriate transmitter manual for connections to the transmitter high and low ports. The Tek-DP 1670A flanged seals require a backup flange rated for the same type and class as the Segmental Wedge Flow Meter.
- Backup flanges with bolts and nuts are generally offered to the transmitter and are not supplied with the Segmental Wedge Flow Meter. Observe recommended torque specifications for the type and class being used.
- Final torque values are dependent on the selected temperature rating of the Segmental Wedge Flow Meter as two different gaskets are employed.

3.4.4 Pipe Connections

Tighten the flange bolts in a 'star' pattern, as shown in Figure 10, to avoid localized stresses on the gaskets.

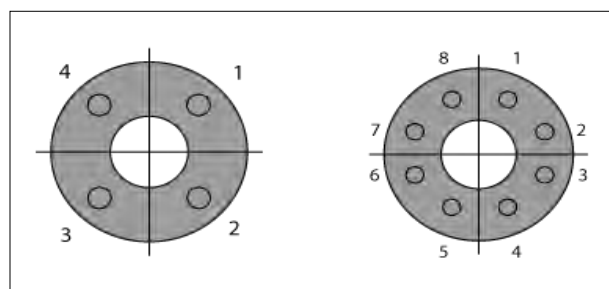

Fig 10: Flange bolt tightening pattern

4 Maintenance

4.1 Removal of Segmental Wedge Flow Meter



WARNING

Process pressure and material retained in the flow element can cause damage to equipment. Standard plant safety procedures must be followed when removing the element from service.

- The Tek-DP 1670A Segmental Wedge Flow Meter has no moving parts that require servicing.
- Removal of the meter is generally not required other than for standard maintenance cleaning of process lines.
- Before removal, shut off all process flow, pressure and drain lines if possible before loosening any bolts.
- Disconnect transmitter connections and remove impulse lines or remote seal elements.
- Loosen and disconnect element line connections and remove from process pipeline.

4.2 Inspection

- Check sealing surfaces periodically for nicks and gouges before reinstallation.
- Elements under severe operating conditions must be inspected for signs of corrosion and erosion to minimize unexpected shutdowns.

5 Troubleshooting

This section provides troubleshooting techniques for most common operating problems shown in table 2.

Table 2: Troubleshooting Techniques

Symptoms	Area	Possible Problem or Solution
No Signal (0mA)	Transmitter	<ul style="list-style-type: none"> • No Power to transmitter. • Transmitter not wired correctly. • Check continuity on wiring or loose connection.
Negative Signal (<0mA)	Transmitter	<ul style="list-style-type: none"> • Transmitter wires are reversed.
Low signal (<4mA)	Tek-DP 1670A	<ul style="list-style-type: none"> • Segmental Wedge Flow Meter is installed backwards, with gauge lines attached as marked. • In this case, the high-pressure tap would be sensing a lower pressure than the low-pressure tap (Note: Meter can be operated in reverse mode with extra transmitter). • This negative DP would force the signal below 4mA.
	Gauge Line	<ul style="list-style-type: none"> • Gauge lines are reversed. Transmitter shows more pressure on lower side than higher side. • Check "H" and "L" marks on Segmental Wedge Flow Meter Differential Pressure Flow Meter.
Zero Signal (4mA)	Tek-DP 1670A	<ul style="list-style-type: none"> • Meter has been damaged.

		<ul style="list-style-type: none"> Remove meter and visually inspect. No flow in pipeline. Check other system locations to verify flow through the meter. The meter could be under pressure but still have no flow.
	Manifold	<ul style="list-style-type: none"> Manifold / gauge lines closed or blocked. Ensure valves and lines are open. If fluid is safe, open vent valves on transmitter to verify pressure in the gauge lines.
Wrong Signal High or Low	Tek-DP 1670A	<ul style="list-style-type: none"> Process conditions do not match actual conditions. Contact Tek-Trol or your sales representative to recalculate using the correct process conditions. Wrong meter. Verify serial numbers on meters to ensure correct specifications. Sometimes two meters are interchanged. Remember each Segmental Wedge Flow Meter has a unique flow coefficient.
	Gauge Lines	<ul style="list-style-type: none"> Foreign material trapped in gauge lines. Dirt and sediment can settle into the gauge lines. If the fluid is safe, vent the gauge lines and inspect for spurts of solids, gasses, or liquids (whichever should not be there). If the fluid is not safe, open the center manifold valve for several minutes under high DP. Close the valve and compare the signal level to before readings. In a horizontal, liquid application, install the meter with the taps on the sides of the pipe (3 or 9 o'clock) For a horizontal, gas application, install at top or sides of the pipe (12, 3, or 9 o'clock).
	Flow Computer	<ul style="list-style-type: none"> Flow calculations have an error. Use loop calibrator and apply 4, 12, and 20mA to computer / system. Each of these points should be correlate with the Segmental Wedge Flow Meter sizing information. Current output signal is read incorrectly. Apply a known current to the loop and read the raw signal in the computer. Most computers allow the user to see the mA signal directly.
Unsteady Signal	Tek-DP 1670A	<ul style="list-style-type: none"> Partially full pipe occurring (liquids only). Periods with a partially full pipe will cause wrong readings. See above for details.
Slow response time	Transmitter	Dampening to long.
Sudden change in readings	Tek-DP 1670A	<ul style="list-style-type: none"> Foreign object lodged in meter.

Signal very High		<ul style="list-style-type: none"> • This will increase the restriction of the meter and raise the DP. • Remove the meter and visually inspect.
	Gauge Lines	<ul style="list-style-type: none"> • There may be leakage in line.
	Tek-DP 1670A	<ul style="list-style-type: none"> • Meter body, near the pressure taps. • If any arrow is not visible and the meter is large than 2", the flow direction can be determined by the location of the pressure taps. • The pressure taps will be closer to the upstream side. • On meters less than 2", the gauge lines will need to be removed. Look at the base of both pressure taps. One tap will be smooth at the base, the other will be mostly weld material. • The smooth tap is on the upstream side. • Flow is going in the opposite direction from what was expected. The assumption of flow direction is sometimes wrong. • Verify with other system readings. • With a meter measuring backward flow, the DP signal will be approximately 30% high. • Partially full pipe (liquids only). A partially full pipe will cause the meter to read very high. This can happen even in pressurized systems. <ul style="list-style-type: none"> ○ On horizontal pipes: If the fluid is safe, open a pressure tap on the top of the pipe. Air release will indicate partially full pipe. ○ On vertical pipes: Up flow will guarantee a full pipe. Down flow is difficult to diagnose if the pipe is full. • Foreign object lodged in meter. This will increase the restriction of the meter and raise the DP. Remove the meter and visually inspect.
	Gauge Lines	<ul style="list-style-type: none"> • Leak on low pressure gauge line. • Perform a leak check from the meter to the transmitter.
	Transmitter	<ul style="list-style-type: none"> • Leak on low pressure vent valve. Perform a leak check on valve. • Zero point has shifted positively. This will cause errors more pronounced at the low end of the transmitter range. • Verify by closing the manifold side valves and opening the center valve. The reading should go to zero (4mA). • Recalibrate if necessary. DP span is set very low. • Use pressure calibrator or handheld communicator to verify span point.
Flow Computer	<ul style="list-style-type: none"> • 4mA set to minimum flow. 	

		<ul style="list-style-type: none"> • Our calculations assume that 4mA will be equal to zero flow. Sometimes 4mA is set to equal the minimum flow on the sizing page. • This error will be zero at maximum flow and increase as the flow decreases. • The amount of error will depend on the zero offset.
Signal Very Low	Manifold	<ul style="list-style-type: none"> • Manifold is cross-vented. The center valve must be closed. • To test, close the two side valves and watch the transmitter signal. • If the signal goes to zero (4 ma), the center valve is not closed completely.
	Gauge lines	<ul style="list-style-type: none"> • Leak on high pressure gauge line. • Perform a leak check from the meter to the transmitter.



TEKMATION LLC reserves the right to change the designs and/or materials of its products without notice. The contents of this publication are the property of TEKMATON and cannot be reproduced by any other party without written permission. All rights reserved. Copyright © 2020 TEKMATON LLC
DOC# /TEK/TPS/MAL/240520/1670A/001
TEKMATION LLC



www.tek-trol.com

Tek-Trol LLC

796 Tek Drive Crystal Lake,
IL 60014, USA

 +1 847-857-6076

 tekrol@tek-trol.com

 www.tek-trol.com

Tek-Trol is a fully owned subsidiary of TEKMATON LLC. We offer our customers a comprehensive range of products and solutions for process, power and oil & gas industries. Tek-Trol provides process measurement and control products for Flow, Level, Temperature & Pressure Measurement, Control Valves & Analyzer systems. We are present in 15 locations globally and are known for our knowledge, innovative solutions, reliable products and global presence.

Flow | Level | Temperature | Pressure | Valves | Analyzers | Accessories | TekValSys