



# ***TEK-DP 1690B*** ***Flow Conditioner***

---

## **Instruction Manual**

Document Number: IM-1690B

### **Plate Type Conditioners**

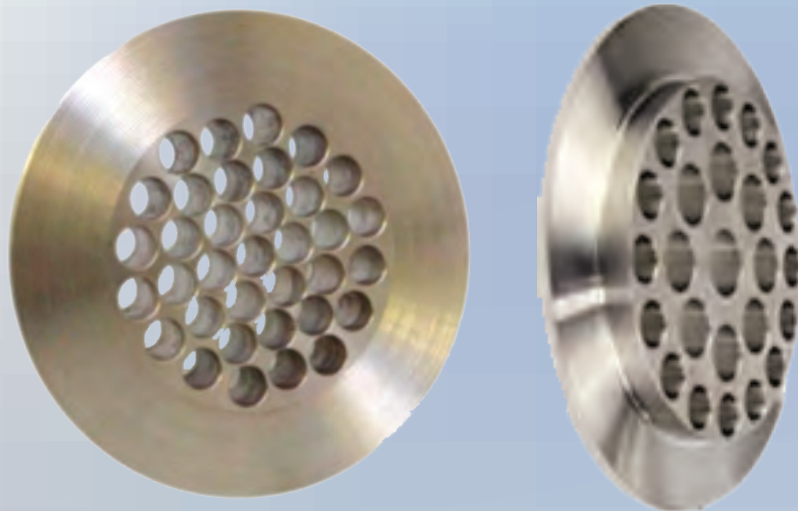

**AGA / API  
Type Tube Bundle**

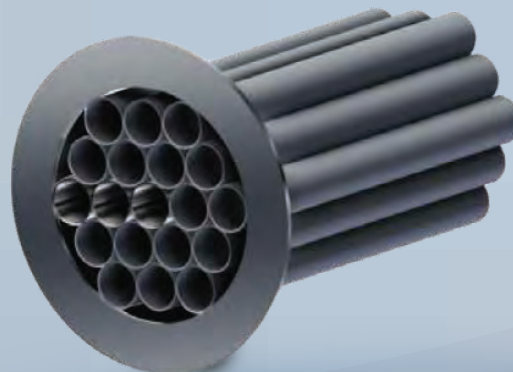

[www.tek-trol.com](http://www.tek-trol.com)

---

**NOTICE**

Read this manual before working with the product. For personal and system safety, and for optimum product performance, make sure you thoroughly understand the contents before installing, using, or maintaining this product.

For technical assistance, contact

Customer Support

796 Tek-Drive

Crystal Lake, IL 60014

USA

Tel: +1 847 857 6076

© **COPYRIGHT Tek-Trol LLC 2021**

No part of this publication may be copied or distributed, transmitted, transcribed, stored in a retrieval system, or translated into any human or computer language, in any form or by any means, electronic, mechanical, manual, or otherwise, or disclosed to third parties without the express written permission. The information contained in this manual is subject to change without notice.

Table of Contents

<b>1</b>	<b>Safety Instructions</b> .....	<b>2</b>
1.1	Intended Use .....	2
1.2	Certifications .....	Error! Bookmark not defined.
1.3	Safety Instructions from the Manufacturer.....	2
1.3.1	Disclaimer.....	2
1.3.2	Product Liability and Warranty.....	2
1.3.3	Information Concerning the Documentation .....	2
1.4	Safety Precautions .....	2
1.5	Packaging, Transportation and Storage.....	3
1.5.1	Packing.....	3
1.5.2	Transportation .....	4
<b>2</b>	<b>Product Description</b> .....	<b>4</b>
2.1	Introduction.....	4
2.2	Conditioner Types.....	5
2.3	Specification .....	6
2.4	Dimensional Drawing .....	7
<b>3</b>	<b>Installation</b> .....	<b>9</b>
3.1	Recommended Upstream and Downstream Requirements .....	12

# 1 Safety Instructions

## 1.1 Intended Use

Tek-DP 1690 B Flow conditioner plates and tube bundles are built for the very best flow conditioning needs. All flow conditioners have been tested and evaluated by independent laboratories and validated in the most demanding situations.

## 1.2 Safety Instructions from the Manufacturer

### 1.2.1 Disclaimer

The manufacturer will not be held accountable for any damage that happens by using its product, including, but not limited to direct, indirect, or incidental and consequential damages.

Any product purchased from the manufacturer is warranted in accordance with the relevant product documentation and our Terms and Conditions of Sale.

The manufacturer has the right to modify the content of this document, including the disclaimer, at any time for any reason without prior notice, and will not be answerable in any way for the possible consequence of such changes.

### 1.2.2 Product Liability and Warranty

The operator shall bear authority for the suitability of the device for the specific application. The manufacturer accepts no liability for the consequences of misuse by the operator. Wrong installation or operation of the devices (systems) will cause the warranty to be void. The respective Terms and Conditions of Sale, which forms the basis for the sales contract shall also apply.

### 1.2.3 Information Concerning the Documentation

To prevent any injury to the operator or damage to the device it is essential to read the information in this document and the applicable national standard safety instructions. This operating manual contain all the information that is required in various stages, such as product identification, incoming acceptance and storage, mounting, connection, operation and commissioning, troubleshooting, maintenance, and disposal.

## 1.3 Safety Precautions

You must read these instructions carefully prior to installing and commissioning the device. These instructions are an important part of the product and must be kept for future reference. Only by observing these instructions, optimum protection of

both personnel and the environment, as well as safe and fault-free operation of the device can be ensured.

For additional information that are not discussed in this manual, contact the manufacturer.

### Warnings and Symbols Used

The following safety symbol marks are used in this operation manual and on the instrument.



#### WARNING

---

Indicates a potentially hazardous situation which, if not avoided, could result in death or serious injury.

---



#### CAUTION

---

Indicates a potentially hazardous situation which, if not avoided, may result in minor or moderate injury. It may also be used to alert against unsafe practices.

---



#### NOTE

---

Indicates that operating the hardware or software in this manner may damage it or lead to system failure.

---

## 1.4 Packaging, Transportation and Storage

### 1.4.1 Packing

The original package consists of

1. Tek-DP 1690B Flow conditioner
2. Documentation



#### NOTE

---

Unpack and check the contents for damages or sign of rough handling. Report damage to the manufacturer immediately. Check the contents against the packing list provided.

---

### 1.4.2 Transportation

- Avoid impact shocks to the device and prevent it from getting wet during transportation.
- Verify local safety regulations, directives, and company procedures with respect to hoisting, rigging, and transportation of heavy equipment.
- Transport the product to the installation site using the original manufacturer's packing whenever possible.

## 2 Product Description

### 2.1 Introduction

Tek-Trol manufactured "Flow Conditioning" plates and tube bundles are built for the very best flow conditioning needs. All flow conditioners have been tested and evaluated by independent laboratories and validated in the most demanding situations. This instruction manual details the requirements to install the Tek-Trol brand of flow conditioning products in a pipeline or skid system three types are supplied.

The installation conditions of flowmeters have a more pronounced effect on their performance than construction. In fact, proper installation conditions tend to provide fully developed and swirl/pulsation-free flow upstream of the flowmeter this is why it is important to review this document before installation.

This flow is very difficult to measure without specific precautions in real practice, because flowmeters are unavoidably installed in assemblies located in plant pipe works downstream of pipe fittings. The main disadvantage of pipe fittings, in this sense, is the generation of distorted velocity profiles associated with varying degrees of swirl at the inlet of flowmeter. The objective of flow conditioning is to create a known and repeatable velocity profile of the substance being measured in order to improve the accuracy of the flow metering process. This is especially critical for compressible fluids like gas when flow is being measured by differential pressure devices that have a restriction in their flow path. Flow conditioning is responsible for eliminating swirl, restoring profile symmetry, and generating a repeatable, fully developed velocity flow profile.

TEK-DP 1690B flow conditioners are widely accepted designs that help to condition the flow upstream of any flow meter that requires a velocity/flow profile correction in natural gas, air, oil & liquified petroleum products, water, and other single-phase fluid applications where applicable. Zanker or Nova Type dependent on customer preference. The installation is similar for both types from an installation pipeline

pressure containment aspect. All 1690B flow conditioning plate units are supplied in SS316/SS316L as standard, from 2" to 36" diameter in RF or RTJ options, other steel materials are available please review the type of unit purchased before installation.

Standard API / AGA 14.3 Tube Bundle Conditioners are supplied available with a model number of 1690-B Type V.

## 2.2 Conditioner Types

The Tek-DP 1690 B Series Flow Conditioners are supplied in the following three configurations:

### **1690 B – V Tube Bundle / Straightening Vane Flow Conditioner**

The Tek DP 1690 B Straightening vanes are designed to be installed in the upstream section of meter tube to minimize flow disturbance prior to reaching an orifice plate, or other meter requiring flow conditioning. These vanes are widely acknowledged as the most utilized flow conditioner design in the market for Orifice measurement, we offer them in various sizes, complying with A.G.A. Flow and A.S.M.E. welding standards, in both carbon steel and stainless steel, see Figures 3 & 4.

The Vane bundle is offered in three distinctive selections, as indicated in Figure 1.: each type comes with either Flange Model or Pin Type fittings. The tubes of every Vane bundle are welded at all tangents (to prevent jetting); the inlets and outlets are reamed to minimize any pressure dissipation. Moreover, uniquely designed gaps on each bundle ensure precise placement within the meter piping. A robust clamp ring (Top-Hat) keeps the Flange Model tight between two pipeline flanges.

### **1690 B – Z Zanker Type Flow Conditioner**

The Zanker Type Flow Conditioning plate is designed to reduce stream turbulence and recreate a velocity profile defined by the ISO 5167-1 standard. It is used when it is impossible to ensure the required upstream and downstream straight length. The flow conditioner plate helps eliminate large deformations of the velocity profile and reduces gross errors in flow measurement. This plate can help to shorten the length of an upstream meter run, see Figures 1. and 5.

The Zanker Plate Flow Conditioner can be used for all fluids, including gases and liquids. It is placed in a flanged joint and manufactured according to standards such as EN, DIN, GOST, American ASME, and ANSI (RF, RTJ) or according to customer requirements and specifications. The Zanker Plate Flow Conditioner is primarily made from stainless steel, although other materials are available upon request. It

can be incorporated into both horizontal and vertical piping and has a long history of operation.

**Tek-DP 1690 B- N Flow Conditioner Plate**

The Tek-DP 1690 B-N flow conditioner is based on the tried and tested Nova Design, and is a compact device consisting of a solid metal disk with a precisely designed and machined hole pattern. Its effectiveness can be attributed to three key design factors.

- a tested hole layout,
- an abrupt localized pressure-drop with a smooth recovery.
- short length.

The hole layout is designed to redistribute the fluid flow across the pipe area, resulting in a balanced and fully developed flow profile at the entry into the flow meter. The layout of the device is carefully crafted to ensure that the fluid is properly balanced and that each hole within the flow conditioner handles the intended amount of fluid. (See Figures 2. and 6.)

From which upstream flow distortions or asymmetry are reduced to manageable levels. The fluid is accelerated as it passes through the perforated plate, effectively acting as a swirl filter section, reducing the rotational vector from the swirl components. The compact length of the flow conditioner helps to prevent the fluid from flow profiles redevelopment within the device itself. As a result, symmetrical and pseudo swirl-free flow velocities exit the flow conditioner, allowing it to recombine into a bulk, swirl-free, and fully developed flow profile after a short distance of from 5 to 8 D's.

**2.3 Specification**

Sizes	2" to 36" Diameter (DN100 to DN900); larger sizes are available
Pressure Classification	Class 150# through 1500#
Standard Bores	Schedule 40, Schedule 80, Others on request
Available Materials	316 / 316L Stainless Steel – Standard Supply Other: Carbon Steel, Alloy 20, Hastelloy, Monel and Duplex.



Types	Nova Design , Zanker Design, Straightening Vane/Tube Bundle Design
Mounting Flanges	150#, 300#, 600#, 900#, 1500#, 2500# lbs.
Performance	In accordance with AGA 3/API 14.3 / ISO 5167 Pt1
Fluid Types	Natural gas, air, light liquids, hydrocarbons, crude oil, water.
Maximum Pressure Rating	ANSI 2500

## 2.4 Dimensional Drawing

### Tube Bundle / Straightening Vane Flow Conditioners.

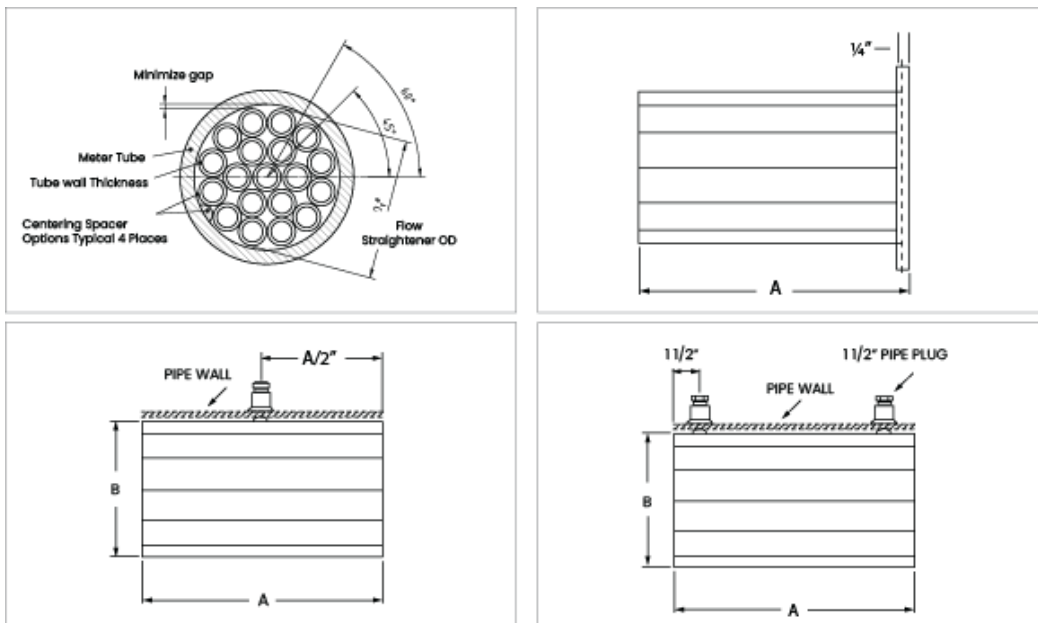

**Fig. 1 Tube Bundle Type (bolt in style and centre ring / top hat style – top right)**

### Zanker Type Plate

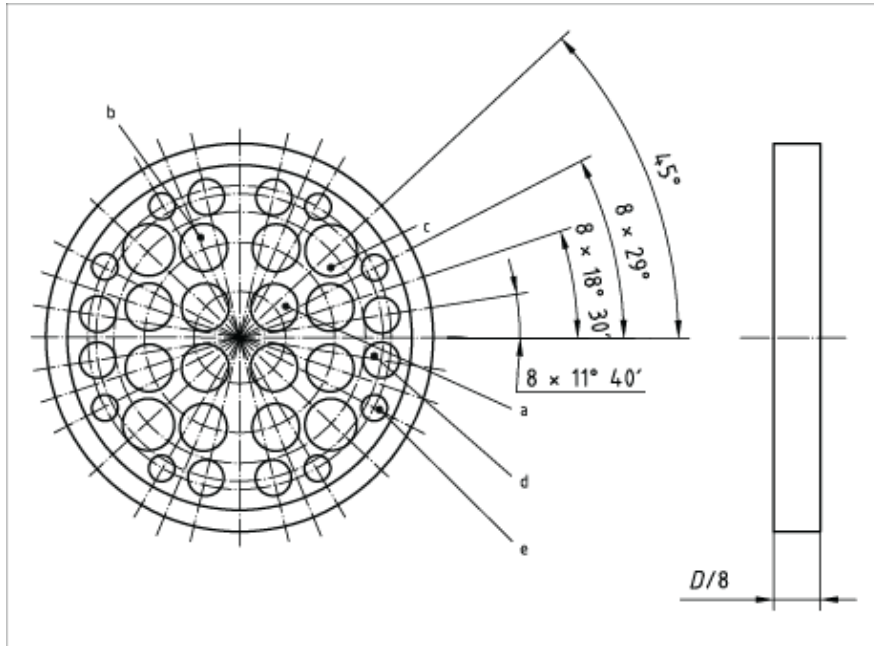

Fig. 2. Zanker Type Conditioning Plate

### Nova Type Plate

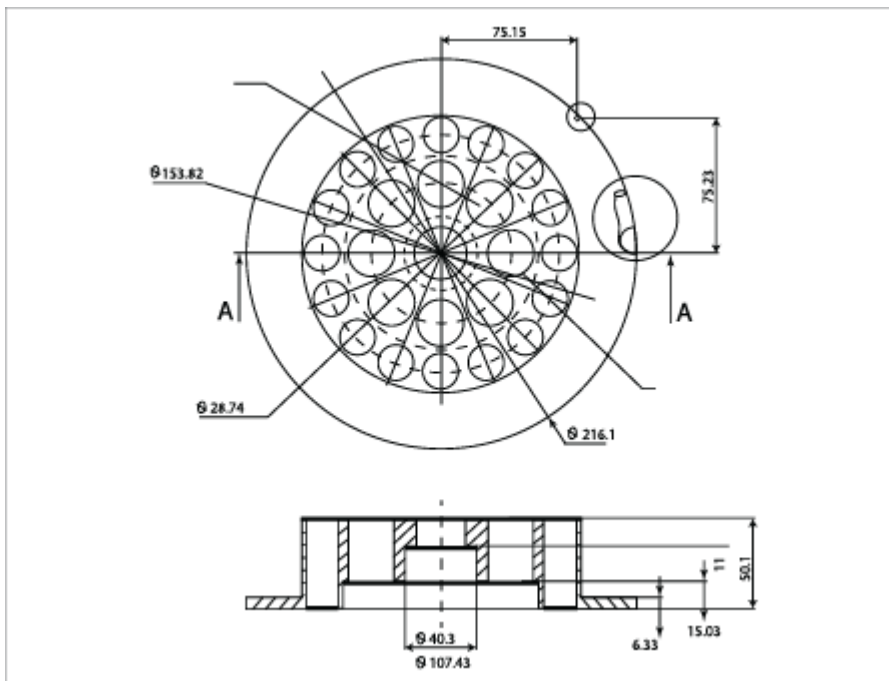
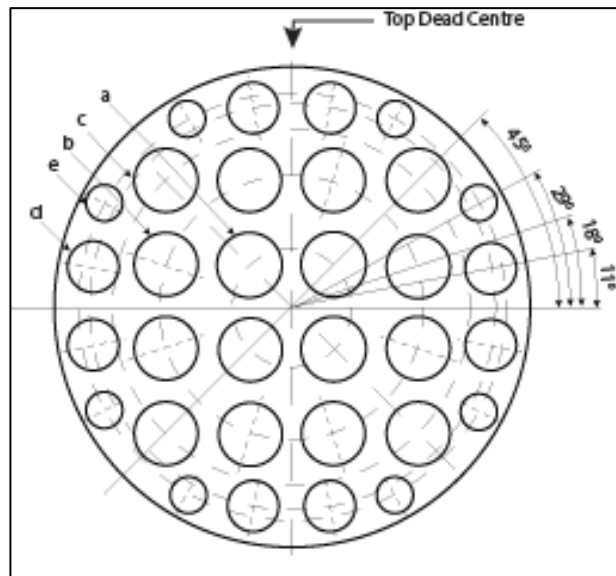

Fig. 3 Nova Type Conditioning Plate

### 3 Installation

Tek-Trol supplied Zanker plates have five grades of holes, as described in Fig. 1 and Table 1., below and at the end of this document listed as variants.

The smaller holes are concentrated near the plate edge because the major formation of eddies and swirl is near to the wall. This radial reduction of hole diameter assists in stabilizing the velocity distribution across the flow area. The geometry of the holes is expressed in terms of plate diameter (i.e., pipe internal diameter).



**Fig 4. Zanker Plate**

Hole grade	Number of holes	Pitch angle	Hole diameter	Pitch circle diameter
a	4	45°	0.141D±0.001D	0.25D±0.002 5D
b	8	18°	0.139D±0.001D	0.56D±0.005 6D
c	4	45°	0.136.5D±0.001D	0.75D±0.0075D
d	8	11°	0.11D±0.001D	0.85D±0.008 5D
e	8	29°	0.077D±0.001D	0.9D±0.009D
Standard Plate Thickness			0.12D ≤ t <sub>p</sub> ≤ 0.15D	
Standard upstream pipe length			17D ≤ L <sub>f</sub>	
Standard downstream pipe length			7.5D ≤ L <sub>s</sub> ≤ L <sub>f</sub> - 8.5D	

**Table 1. Zanker Plate Geometry**

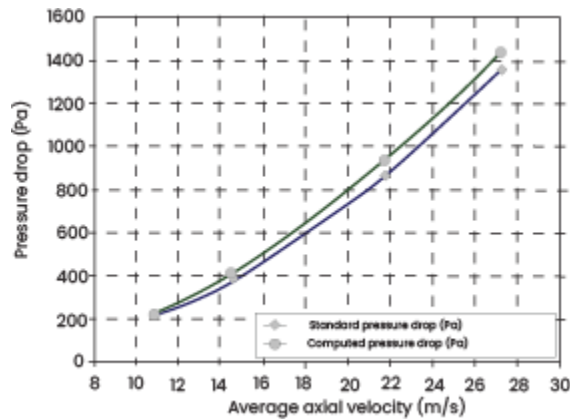

The resultant pressure drop across Zanker plates can be compared with ISO modeling 2003 using the standard equation below, which calculates the pressure drop as a function of the dynamic head:

$$\Delta P = K \frac{1}{2} \rho V^2$$

(Where K is the coefficient of discharge, estimated at a value (ISO, 2003) appx 3.  $\rho$  = the fluid density &  $V$  = fluid velocity.)

It is important to install the plate between approved flanges rated for the design pressure in the center of the pipe with the plate top dead center (shown in Figure 1.) and in the correct place. This methodology also applies to the Nova style plate that Tek-Trol supply if this style was purchased (Figure 2.). If the plate is installed off center "jetting" may occur and may reduce its flow conditioning performance. Figure 3., illustrates the standardized tube conditioner as per AGA / API standards. Occasionally the tube bundle is installed without flanges and placed in the pipe using a threaded tapping and bolt system to hold in place. This is also installed in a similar manner to the plate conditioner with the flanged (Top-Hat) section (if used) installed between pipeline flanges with the tubes facing downstream from the flow direction.

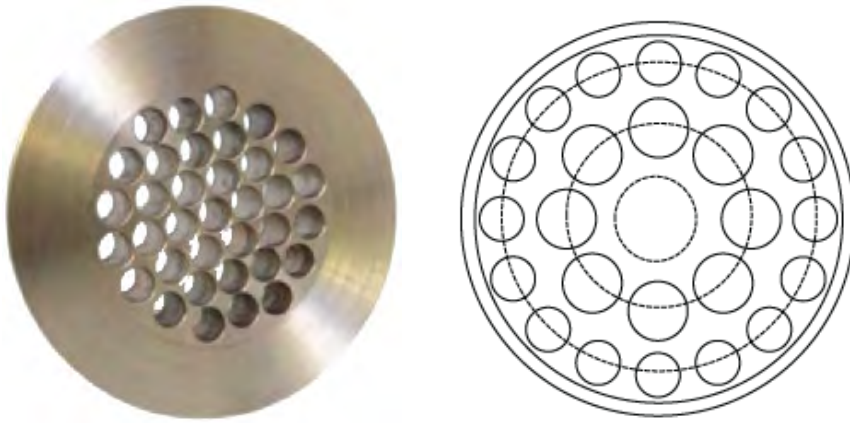

**Fig 5. Nova Style Plate Design**

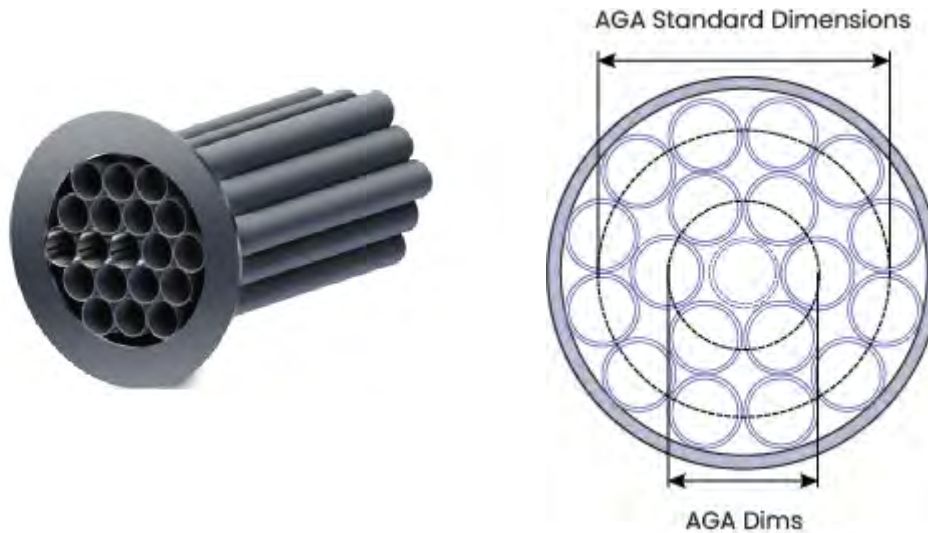

**Fig 6. AGA Style Tube Bundle (with top hat) (1690 B)**

The basic procedure to install as follows: (Note: Some users may use their own approved procedures in house)

- 1. Preparation:** Gather all the necessary tools and equipment for the installation, ensuring they are compatible with the pipeline's material and dimensions use PPE to prevent personal injury during the install.
- 2. Pipeline Shutdown:** Before any work begins, safely shut down the pipeline and ensure it is depressurized to create a safe working environment if new inspect the upstream sections for trash or residue from the manufacturing or welding processes.
- 3. Pipeline Cleaning:** Thoroughly clean the interior of the pipeline to remove any debris, scale, or contaminants that could interfere with the installation if the pipeline is existing, and the installation is an upgrade etc.

4. **Measurements:** Measure the diameter of the pipeline accurately to confirm the appropriate size of the flow conditioning plate.
5. **Plate Positioning:** Confirm the ideal location within the pipeline for installing the flow conditioning plate is correct based on manufacturer recommendations. It is installed in a straight pipe section, downstream from any disturbances or fittings with a downstream section before the meter as per pre-order Tek-Trol recommendations.
6. **Cutting the Pipeline:** Make a precise cut in the pipeline at the designated installation location where the flanges are to be installed up and downstream of the plate the flanges must be at 90 degrees to the centreline of the pipe and also any weld bead ground down. Ensure the cut is clean and straight to facilitate a proper fit and not slanted at an angle as this will prevent the proper flow conditioning process to take place.
7. **Installation:** Insert the flow conditioning plate into the pipeline section in between the flanges using the correct sealing gaskets for the ANSI rating of the flange and pipe. Secure the conditioner in place using bolting, or other appropriate methods, depending on the plate design and pipeline material. Also make sure it is centrally mounted, or this can cause poor flow conditioning performance.
8. **Sealing:** Make sure that the installed flanges create a strong and leak-proof connection, the gasket should also be mounted on the centreline so that the gasket does not protrude inside and affect the velocity profile pressure testing may be required at the discretion of the user.
9. **Testing and Inspection:** Conduct pressure tests and visual inspections to ensure the proper installation of the flow conditioning plate and check for any potential leaks or issues per user operational procedures.
10. **Recommissioning:** After successful installation and testing and recommission the pipeline, restore the fluid flow within it making sure that any air introduced is bleed from the system effectively.
- 11.

### 3.1 Recommended Upstream and Downstream Requirements

#### 1. 1690 B -V Tube Bundle/ Straightening Vane Flow Conditioner

The straight lengths given in the table are the permitted lengths between the downstream end of a 19-tube bundle flow straightener (1998) (as described in 6.3.2.1) and the orifice plate given that a particular fitting is installed upstream of the 19-tube bundle flow straightener (1998) at a distance  $L_f$  from the orifice plate. The

distance  $L_f$  from the orifice plate is measured to the downstream end of the curved portion the nearest (or only) bend or of the tee or the downstream end of the curved or conical portion of the reducer or expander. The recommended values give tube bundle locations that are applicable over a specified range of  $\beta$ .

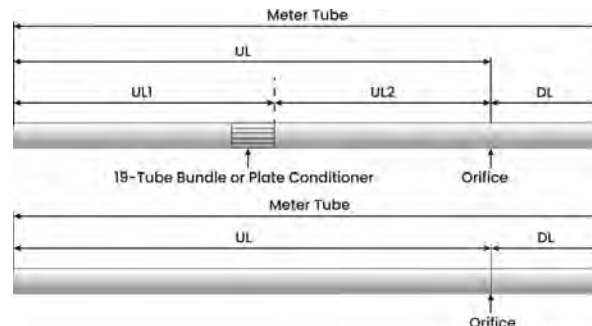

**Fig 7. Basic Straight Run Layout**

Diameter Ratio $\beta$	Single 90° bend <sup>b</sup>				Two bend <sup>b</sup> in perpendicular planes (2D <sub>2S</sub> ) <sup>a</sup>			
	30 > L <sub>r</sub> > 18		L <sub>r</sub> > 30		30 > L <sub>r</sub> > 18		L <sub>r</sub> > 30	
1	2		3		4		5	
-	A <sup>c</sup>	B <sup>d</sup>	A <sup>c</sup>	B <sup>d</sup>	A <sup>c</sup>	B <sup>d</sup>	A <sup>c</sup>	B <sup>d</sup>
0.2	5 to 14.5	1 to n <sup>e</sup>	5 to 25	1 to n <sup>e</sup>	5 to 14.5	1 to n <sup>e</sup>	5 to 25	1 to n <sup>e</sup>
0.4	5 to 14.5	1 to n <sup>e</sup>	5 to 25	1 to n <sup>e</sup>	5 to 14.5	1 to n <sup>e</sup>	5 to 25	1 to n <sup>e</sup>
0.5	11.5 to 14.5	3 to n <sup>e</sup>	11.5 to 25	3 to n <sup>e</sup>	9.5 to 14.5	1 to n <sup>e</sup>	9 to 25	1 to n <sup>e</sup>
0.6	12 to 13	5 to n <sup>e</sup>	12 to 25	5 to n <sup>e</sup>	13.5 to 14.5	6 to n <sup>e</sup>	9 to 25	1 to n <sup>e</sup>
0.67	13	7 to n <sup>e</sup>	13 to 16.5	7 to n <sup>e</sup>	13.5 to 14.5	7 to n <sup>e</sup>	10 to 16	5 to n <sup>e</sup>
0.75	14	8 to n <sup>e</sup>	14 to 16.5	8 to n <sup>e</sup>	f	9.5 to n <sup>e</sup>	12 to 12.5	8 to n <sup>e</sup>
Recommended	13 for $\beta \leq 0.67$	13 for $\beta \leq 0.75$	14 to 16.5 for $\beta \leq 0.75$	14 to 16.5 for $\beta \leq 0.75$	13.5 to 14.5 for $\beta \leq 0.67$	13.5 to 14.5 for $\beta \leq 0.75$	12 to 12.5 For $\beta \leq 0.75$	12 to 12.5 For $\beta \leq 0.75$

Diameter Ratio $\beta$	Single 90° tee				Any fitting			
	30 > L <sub>r</sub> > 18		L <sub>r</sub> > 30		30 > L <sub>r</sub> > 18		L <sub>r</sub> > 30	
1	6		7		8		9	
-	A <sup>c</sup>	B <sup>d</sup>	A <sup>c</sup>	B <sup>d</sup>	A <sup>c</sup>	B <sup>d</sup>	A <sup>c</sup>	B <sup>d</sup>
0.2	5 to 14.5	1 to n <sup>e</sup>	5 to 25	1 to n <sup>e</sup>	5 to 11	1 to n <sup>e</sup>	5 to 13	1 to n <sup>e</sup>
0.4	5 to 14.5	1 to n <sup>e</sup>	5 to 25	1 to n <sup>e</sup>	5 to 11	1 to n <sup>e</sup>	5 to 13	1 to n <sup>e</sup>
0.5	11 to 13	1 to n <sup>e</sup>	11.5 to 25	3 to n <sup>e</sup>	fg	3 to n <sup>e</sup>	11.5 to 14.5	3 to n <sup>e</sup>
0.6	F h	7 to n <sup>e</sup>	12 to 25	5 to n <sup>e</sup>	f	7 to n <sup>e</sup>	12 to 16	6 to n <sup>e</sup>
0.67	f	8 to n <sup>e</sup>	13 to 16.5	7 to n <sup>e</sup>	f	8 to 10	13	7 to „1.5 <sup>e</sup>
0.75	f	9 to n <sup>e</sup>	14 to 16.5	8 to n <sup>e</sup>	f	9.5	f	8 to 22
Recommended	13 for $\beta \leq 0.54$	13 for $\beta \leq 0.75$	14 to 16.5 for $\beta \leq 0.75$	14 to 16.5 for $\beta \leq 0.75$	9.5 for $\beta \leq 0.75$	9.5 for $\beta \leq 0.75$	13 for $\beta \leq 0.67$	13 for $\beta \leq 0.75$

Permitted range of straight lengths between an orifice plate and a 19-tube bundle flow straightener (1998) downstream of fittings located at a distance,  $L_f$ , from the orifice plate.

Where:

- S is the separation between the two bends measured from the downstream end of the curved portion of the upstream bend to the upstream end of the curved portion of the downstream bend.
- Bends should have a radius of curvature equal to  $1,5D$ .
- Column A for each fitting gives lengths corresponding to “zero additional uncertainty” values (see 6.3.2.3.2).
- Column B for each fitting gives lengths corresponding to “0,5 % additional uncertainty” values (see 6.3.2.3.3).
- n is the number of diameters such that the upstream end of the 19-tube bundle flow straightener (1998) is situated  $1D$  from the downstream end of the curved or conical portion of the nearest fitting. It is desirable that the length between the upstream end of the 19-tube bundle flow straightener (1998) and the downstream end of the curved or conical portion of the nearest fitting should be at least  $2,5D$ , except where this would not give an acceptable value for the distance between the orifice plate and the downstream end of the 19-tube bundle flow straightener (1998).
- It is not possible to find an acceptable location for a 19-tube bundle flow straightener (1998) downstream of the fitting for all values of  $L_f$  to which the column applies.
- If  $\beta = 0,46$  a value of 9,5 is possible.
- If  $\beta = 0,54$  a value of 13 is possible.

## 2. Tek-DP 1690B-Z Zanker Plate Flow Conditions

Beyond  $10D$  from the orifice plate, no additional uncertainty in the discharge coefficient is involved provided that the diameter step (the difference between the diameters) between any two sections does not exceed 2 % of the mean value of  $D$  obtained from the measurements specified in (ISO 5167-2 clause no 6.4.2.) Moreover, the actual step caused by misalignment and/or change in diameter shall not exceed 2 % of  $D$  at any point of the internal circumference of the pipe. If the pipe diameter upstream of the step is greater than that downstream of it, the permitted diameter and actual steps are increased from 2 % to 6 % of  $D$ . On each side of the step, the pipe shall have a diameter between  $0,98D$  and  $1,06D$ . Beyond  $10D$  from the orifice plate, the use of gaskets between sections will not violate this requirement provided that in use they are no thicker than 3,2 mm and they do not protrude into the flow.



At a location which is both beyond 10D from the orifice plate and beyond the first location where an expander could be fitted in accordance with Column 10A of Table 3, no additional uncertainty in the discharge coefficient is involved provided that the diameter step (the difference between the diameters) between any two sections does not exceed 6 % of the mean value of D obtained from the measurements specified in 6.4.2.

Moreover, the actual step caused by misalignment and/or change in diameter shall not exceed 6 % of D at any point of the internal circumference of the pipe. On each side of the step, the pipe shall have a diameter between 0,94D and 1,06D.

An additional uncertainty of 0,2 % shall be added arithmetically to the uncertainty for the discharge coefficient if the diameter step ( $\Delta D$ ) between any two sections exceeds the limits given in 6.4.3 but complies with the following relationship:

$$\frac{\Delta D}{D} < 0.002 \left( \frac{\frac{s}{D} + 0.4}{0.1 + 0.3 \beta^4} \right) \quad \text{and} \quad \frac{\Delta D}{D} < 0.05$$

where s is the distance of the step from the upstream pressure tapping or, if a carrier ring is used, from the upstream edge of the recess formed by the carrier ring.

If a step is greater than any one of the limits given in the inequalities above or if there is more than one step outside the limits, the installation is not in accordance with this part of ISO 5167.

No diameter of the downstream straight length, considered along a length of at least 2D from the upstream face of the orifice plate, shall differ from the mean diameter of the upstream straight length by more than 3 %. This can be judged by checking a single diameter of the downstream straight length. Mating flanges would require the bores to be matched and the flanges aligned on installation. Dowels or self-centring gaskets could be used.

3. Tek-DP 1690B-N Flow Conditions Plate

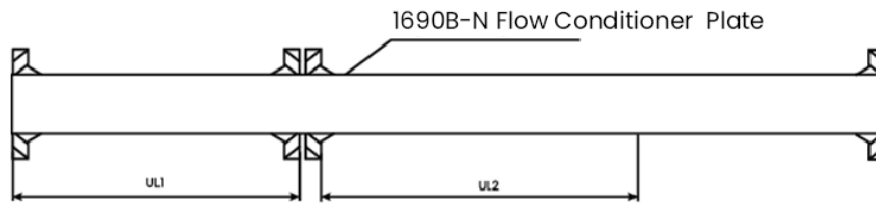

**Fig 8. Pipe Run Length**

The AGA3-2000/ISO-5167 standards provide guidelines indicating that when using a 1690 B N Flow Conditioner Plate, a meter run length of at least 13 times the pipe diameter (13D) or 17 times the pipe diameter (17D) is suggested. Conversely, a meter run length of 10 pipe diameters is universally recommended for different types of flow meters, such as turbine, ultrasonic, vortex, annubar, and venturi meters.



TEKMATION LLC reserves the right to change the designs and/or materials of its products without notice. The contents of this publication are the property of  
TEKMATION and cannot be reproduced by any other party without written permission. All rights reserved. Copyright © 2022 TEKMATON LLC  
DOC#TEK/TPS/MNL/240520/1609/01  
TEKMATION LLC



[www.tek-trol.com](http://www.tek-trol.com)

## **Tek-Trol LLC**

796 Tek Drive Crystal Lake,  
IL 60014, USA

 +1 847-857-6076

 [tektrol@tek-trol.com](mailto:tektrol@tek-trol.com)

 [www.tek-trol.com](http://www.tek-trol.com)

Tek-Trol is a fully owned subsidiary of TEKMATON LLC. We offer our customers a comprehensive range of products and solutions for process, power and oil & gas industries. Tek-Trol provides process measurement and control products for Flow, Level, Temperature & Pressure Measurement, Control Valves & Analyzer systems. We are present in 15 locations globally and are known for our knowledge, innovative solutions, reliable products and global presence.

Flow | Level | Temperature | Pressure | Valves | Analyzers | Accessories | TekValSys