

# Tek-Thermal 1700B



# Quick Start Guide

## 1. Before You Begin

This guide provides basic guidelines to assist you in quickly getting started.



Installation of the transmitter in an explosive environment must be in accordance with the appropriate local, national, and international standards, codes, and practices. Review the approvals section of the Tek-Thermal 1700B reference manual for any restrictions associated with a safe installation.



Do not remove the transmitter covers in explosive environments when the circuit is live.



Ensure the transmitter is installed by qualified personnel and in accordance with the applicable code of practice

## 2. Unpack

Tek-Thermal 1700B Thermal Mass Flowmeter

## 3. Dimensional Drawing

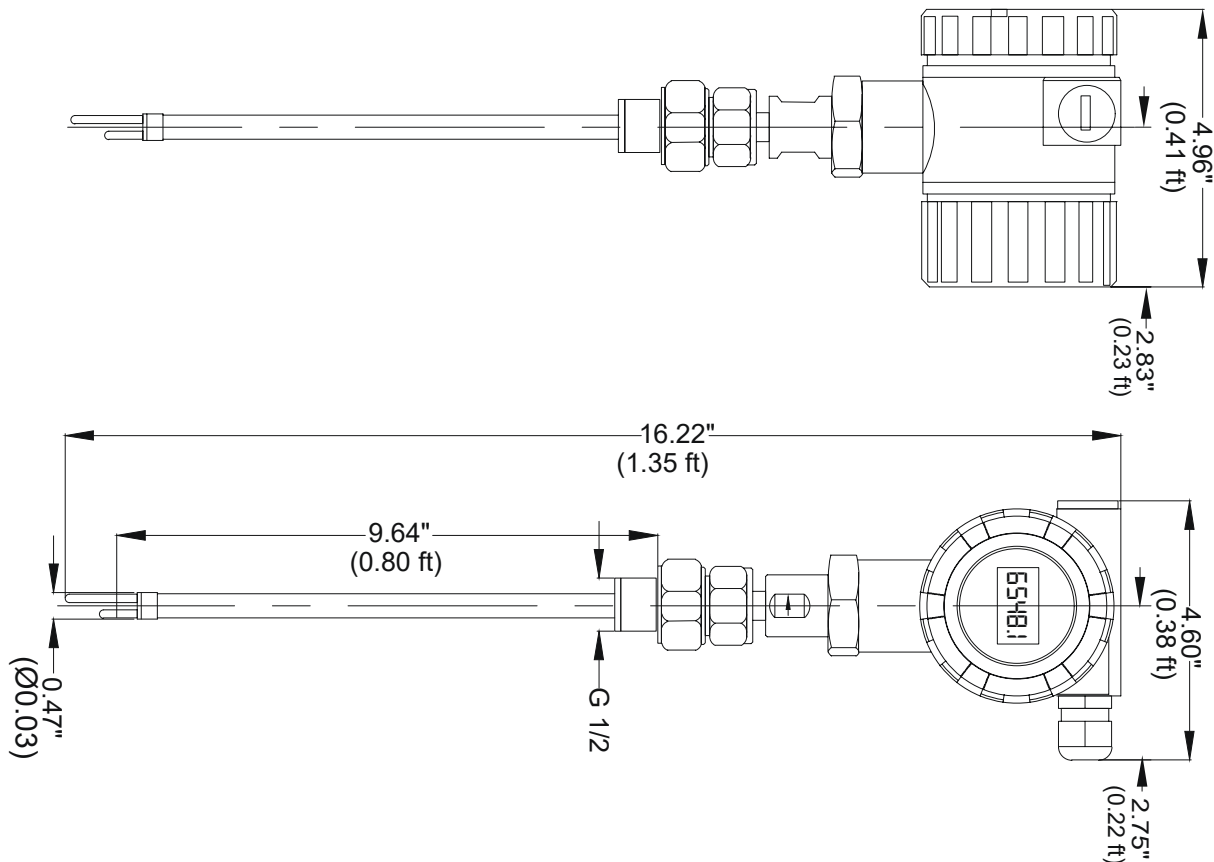

## 4.Display

The Tek-Thermal 1700B Thermal Mass Flowmeter provides local display and settings to display several variables on the local multifunctional LCD display. It has 3 buttons.

The Tek-Thermal 1700B Thermal Mass Flowmeter has a display to indicate “Temperature”, “Flow Rate”, “Total flow”, and other parameters.

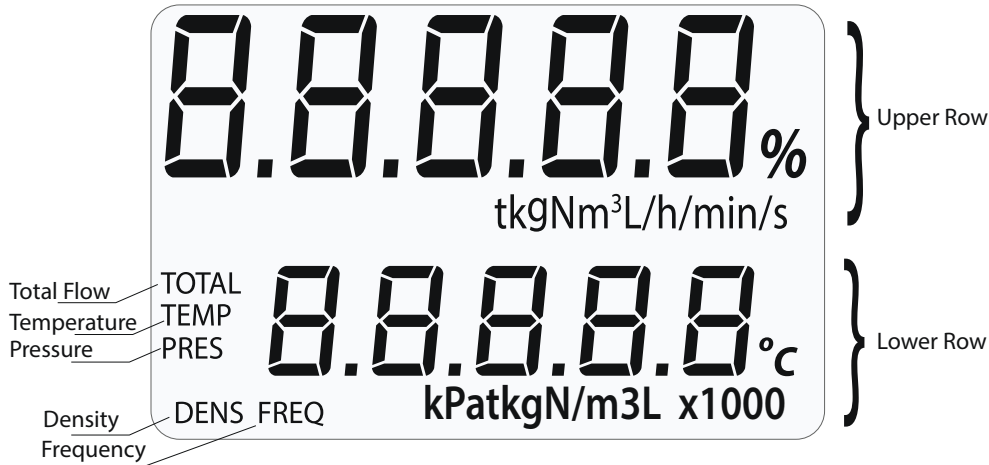

The LCD display has 2 areas to display the content, the upper row and lower row. The upper row displays the Volume Flow Rate or Mass Flow Rate. Immediately underneath the upper row, the unit of the variable displayed in upper row is shown.

The lower row display indicates variables such as Frequency, Pressure, Temperature, Density, Total Flow, or Velocity. Immediately underneath the lower row, the unit of the variable displayed in lower row shown.

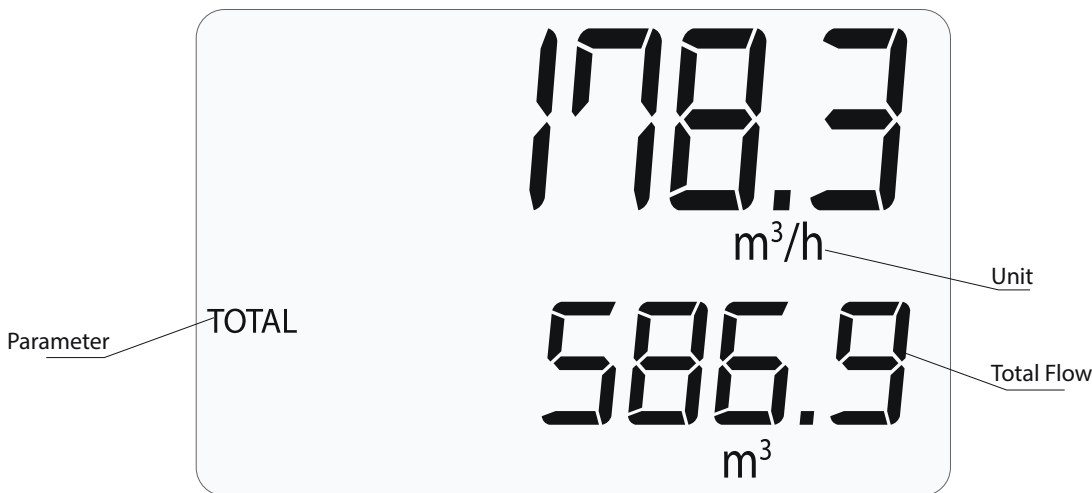

# Quick Start Guide

## 5. Power Supply

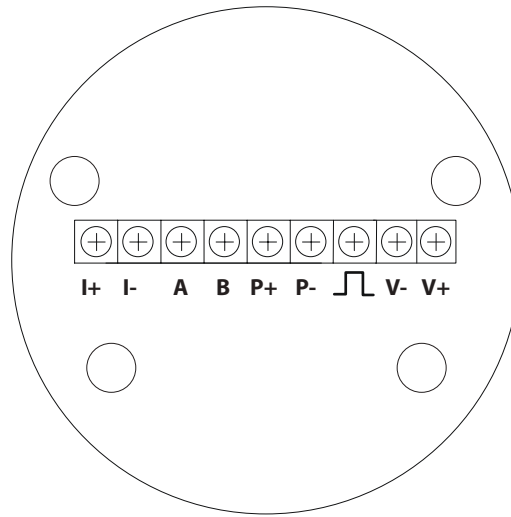

Power Supply	V+
	V-
Pulse Output	□
RS 485 Communication	A+
	B-
Current	I+
	I-
Pressure Sensor	P+
	P-

### For 3-Wire Pulse Output

3-wire pulse output requires a power source of 13.5 to 42 VDC. Tek-Thermal 1700B uses a current pulse output with 50% duty ratio. The resistance should be within 500  $\Omega$  to 1000  $\Omega$ , and power consumption should be no less than 0.5 W.

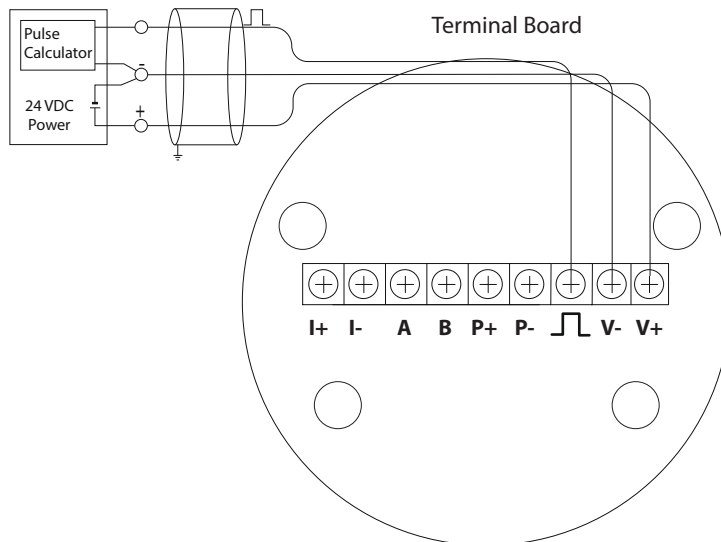

## For 3-Wire HART with 4-20 mA

When using a HART communicator, add a 250  $\Omega$  load resistor.

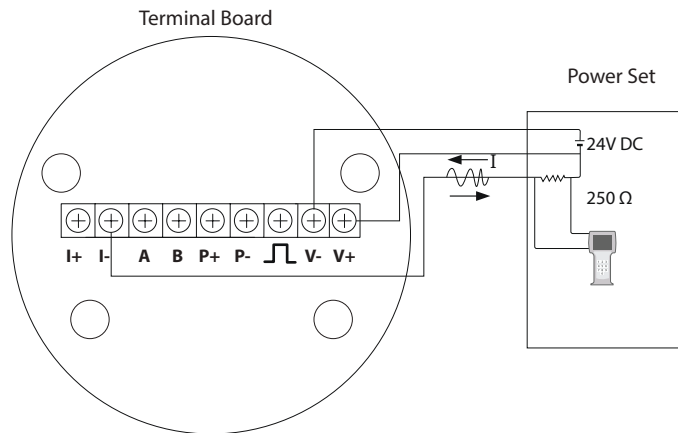



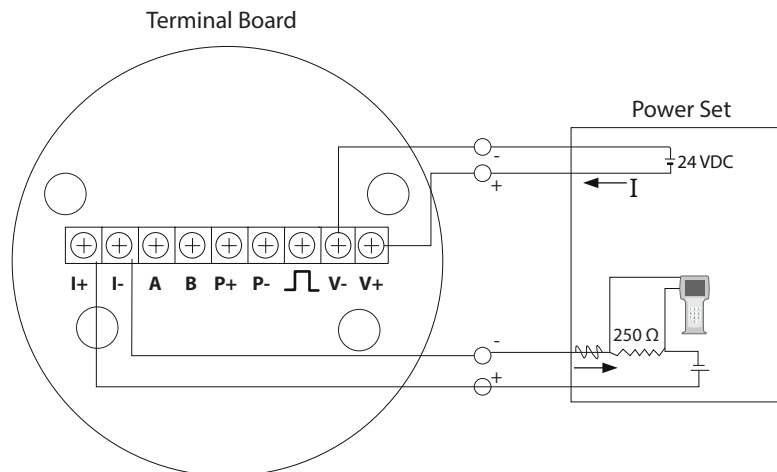

## For 4-Wire HART with 4-20 mA

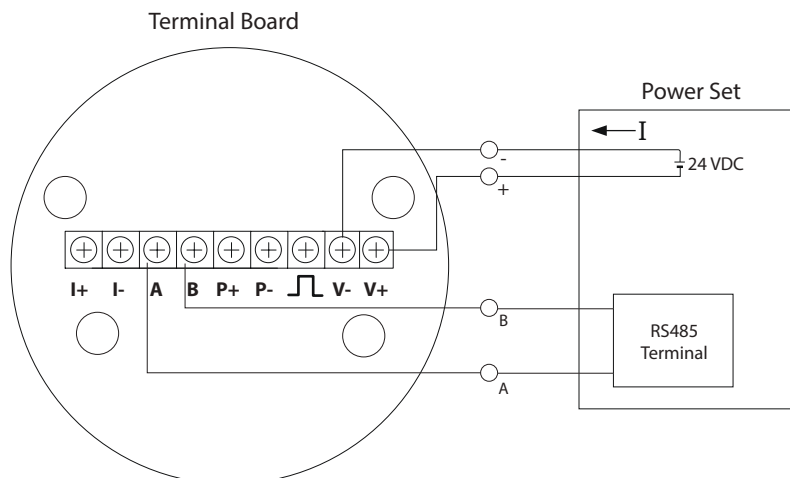

## For RS485



# Quick Start Guide

-  Before doing wiring work, turn OFF the power supply, to prevent electric shocks.
-  Connect to a power source with the correct rating to prevent an accident.
-  Ensure installation of the transmitter meets applicable state and national electrical code requirements.
-  Do not remove the transmitter covers in explosive environments when the circuit is live.
-  Both transmitter covers must be fully engaged to meet explosion-proof requirements.

## 6. Grounding

In the Tek-Thermal 1700B Thermal Mass Flowmeter, the power supply of the signal processing circuit is transferred from outside power supply by an isolation type DC-to-DC transmitter, using advanced grounding technology. The field frequency interference can be also be isolated. When using this product, the “V-” of power supply should not be connected with the ground. When this product is used in an environment with strong interference, the shell should be in connection with the earth through the cable, so the interference can be eliminated.

**Note:** Make sure that the flowmeter is properly grounded.

Do not connect wiring when the power is on in an explosive environment.



Open the rear cover first, then insert the cable into back zone of housing through the waterproof cable gland.

## 7. Communication

- The communication interface should be RS485, the range of Baud rate should be 1200 to 115200.
- The wiring terminal is “A” and “B”. Refer to section 5. (Power Supply) of this Quick Start Guide for wiring terminal information.
- The communication should comply with the MODBUS-RTU statute.

**Note:** For more information on communication, refer to the detailed manual.

## 8. Configuration

The configuration of Tek-Thermal 1700B can be done with the help of 3 display buttons,  the L-R button,  the U-D button, and  the Enter button.

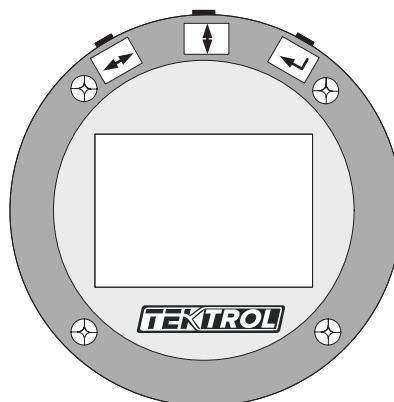

“U-D” button switches the displaying content, “L-R” button can be used shifts the digits left and right of total flow. The “Enter” button is used to display the entire digits of total flow directly.

## Status

The Tek-Thermal 1700B Thermal Mass Flowmeter has three different statuses:

- Working Status
- Setting Status
- Calibration Status

When under Setting Status, you can set the flowmeter, while it is still processing, setting won't have any effect on the measuring parameters. The calibration of the flowmeter is done in the manufacturer's laboratory before delivery, including temperature and pressure calibration and the setting of high limit and low limit of 4 to 20 mA stimulation output.

## Parameter Setting

The Tek-Thermal 1700B Thermal Mass Flowmeter has Digit and Code settings. Use the Code setting to set parameters such as fluid type, compensation type, and output signal. Use the Digit setting to set parameters related to a number, such as pipe size and, flow range factor.

### For Code Setting:

Under working status, to enter the Code setting, hold down the “Enter” button and press the “U-D” button at the same time.

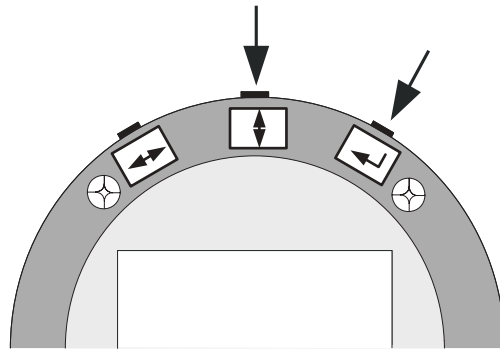

### For Digit Setting:

Under working status, to enter the Digit setting, hold down the “Enter” button and press “L-R” button at the same time.

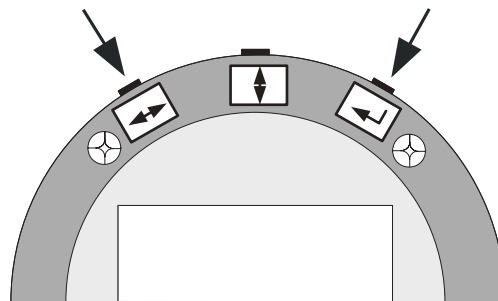

# Quick Start Guide

**Note:** For more information on the Code Setting Address and Digit Setting Address, refer to the detailed manual.

**Note:** The Tek-Thermal 1700B Thermal Mass Flowmeter has been set according to requirement before delivery, please do not change the setting unless it is necessary and only under correct instruction.

## 9. Flow Direction



There is a flow arrow which indicates the flow direction in front of the sensor, so please install the Tek-Thermal 1700B accordingly. Otherwise, the transmitter may not display the flow rate correctly.

## 10. Installation

### Standard Installation

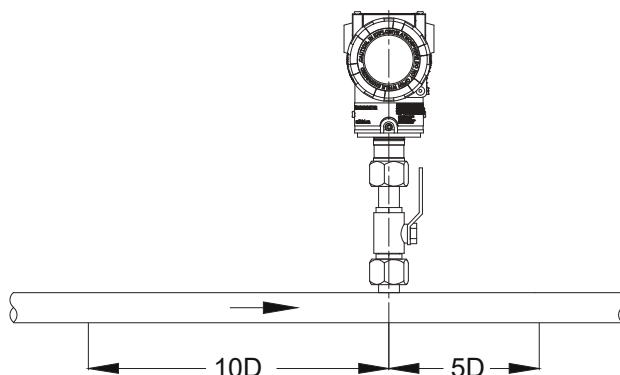



## Installation for the Bend Pipeline that is Upstream or Downstream

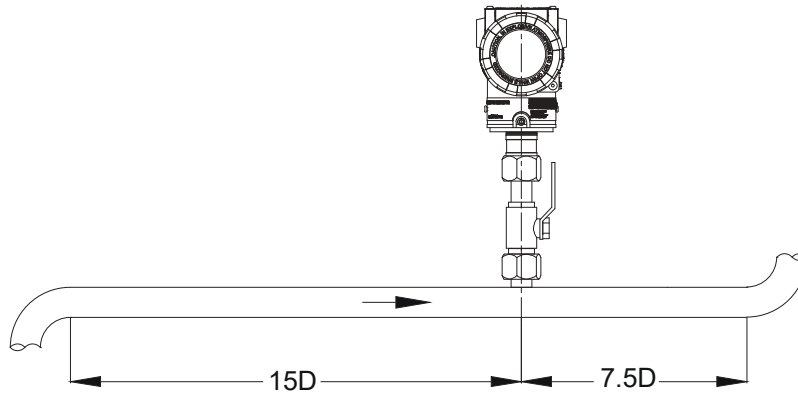

## Installation for the Bend Pipeline that May Cause Turbulence in the Upstream or Downstream

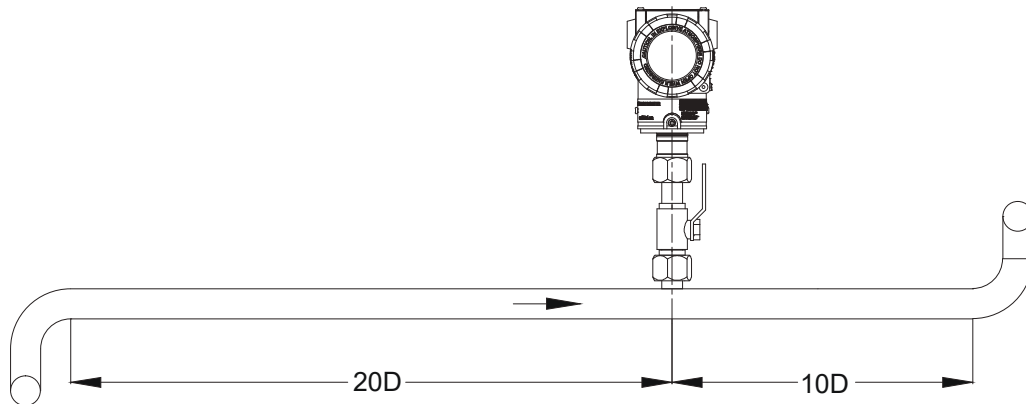

## Installation when Valves, Pressure Controller, or Other Device May Cause Turbulence in the Upstream or Downstream of the Flowmeter

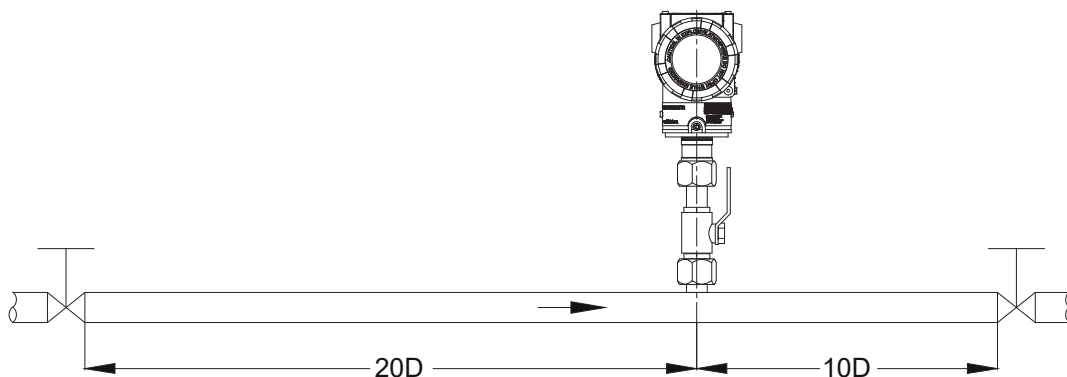

# Quick Start Guide

## Installation for Pipe Expander

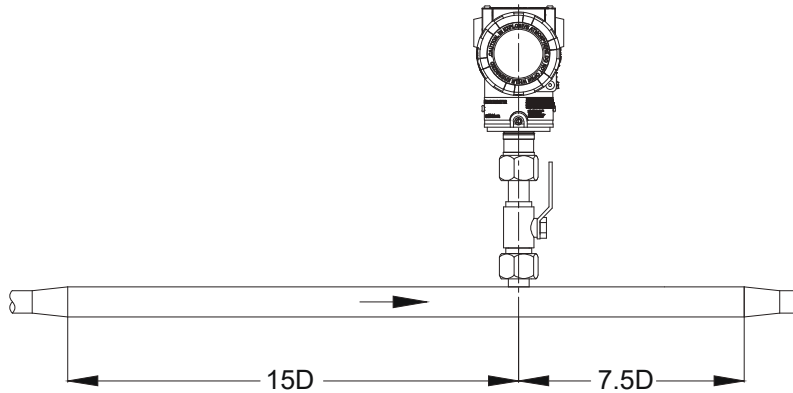

## Installation for Pipe Reducer

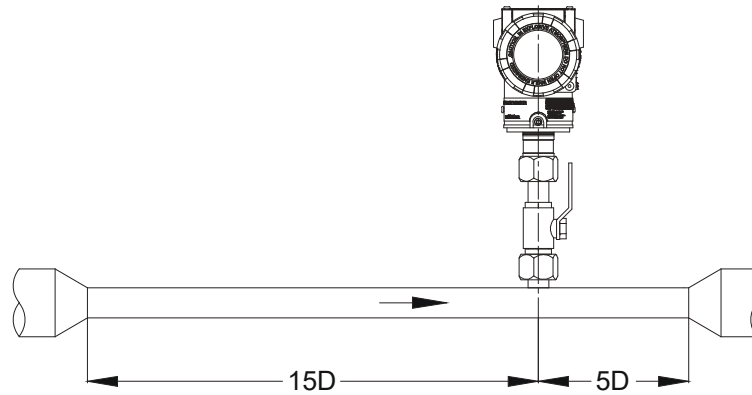

## Requirement on Insertion Direction

On a Horizontal Pipeline, Normal Air, or Gas

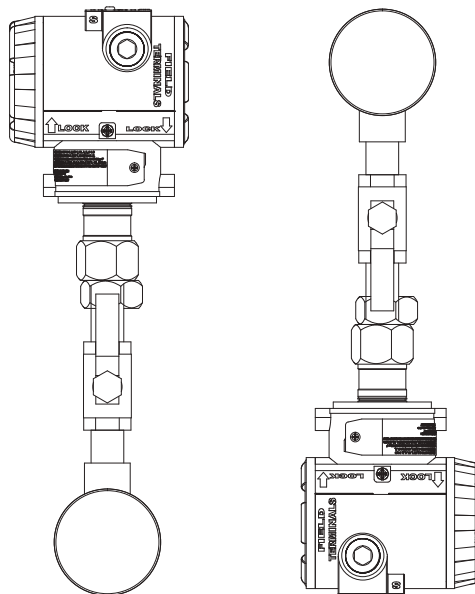

Above or Under the Pipeline

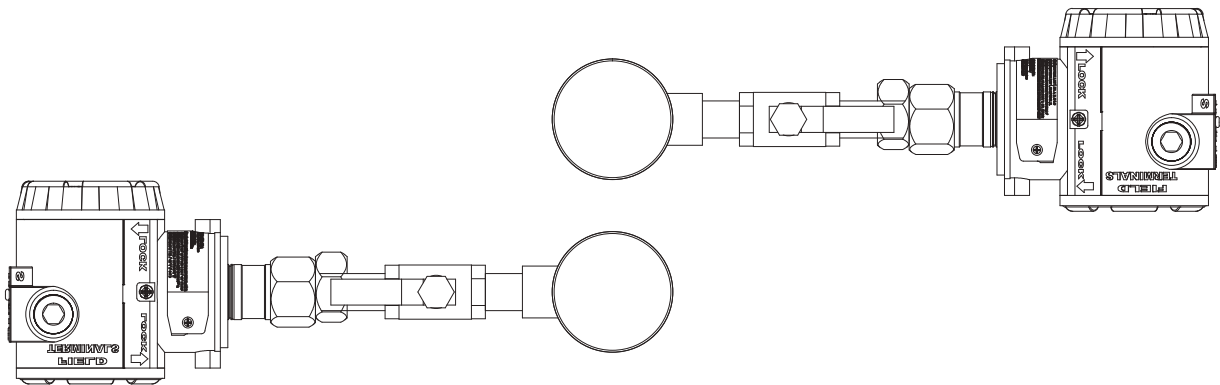

Side of the Pipeline

## On a Horizontal Pipeline, High Humidity Air, or Wet Natural Gas

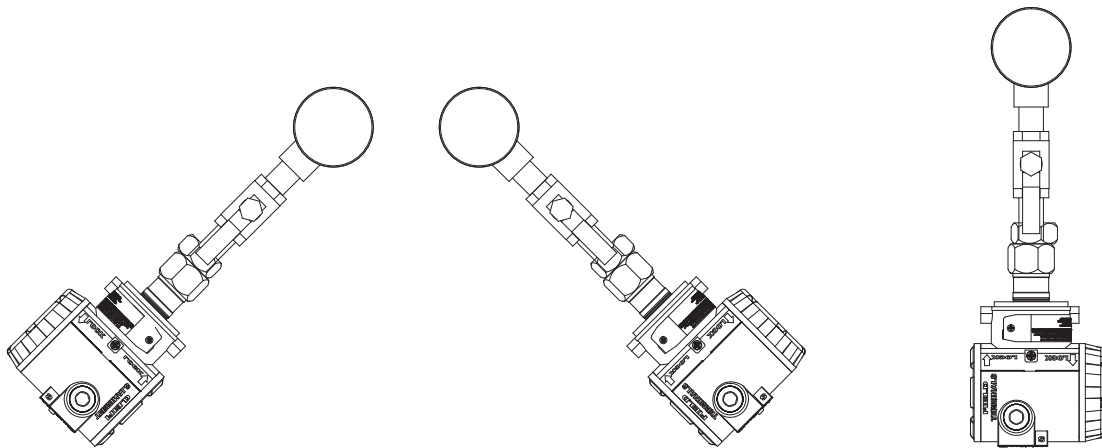

45° Degree Under the Pipeline or just Under the Pipeline

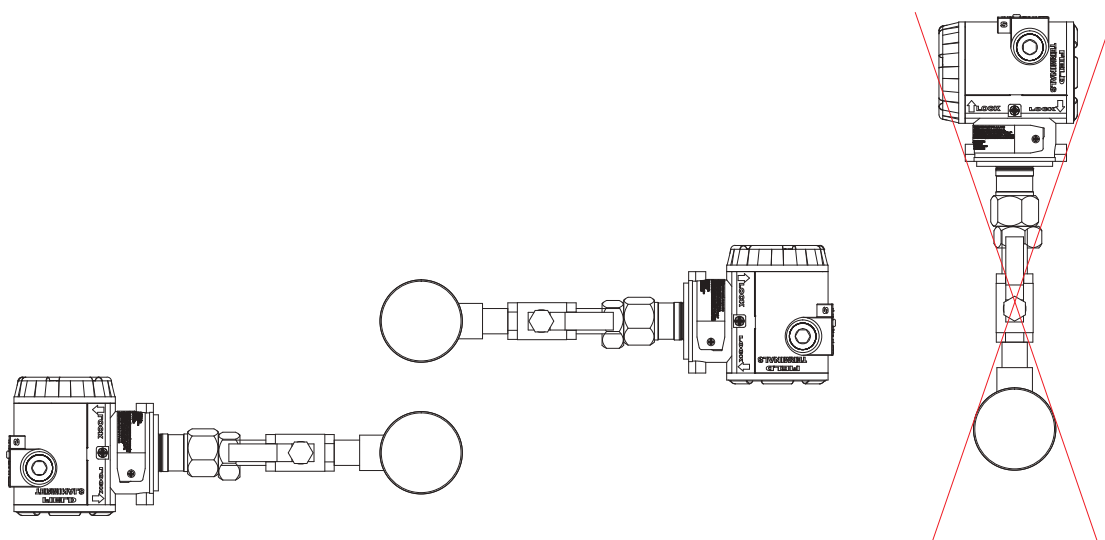

On the Side of the Pipe. The Flowmeter Should Not Be Installed Above the Pipeline

# Quick Start Guide

On a Vertical Pipeline, when the Density of the Gas is Higher than Air

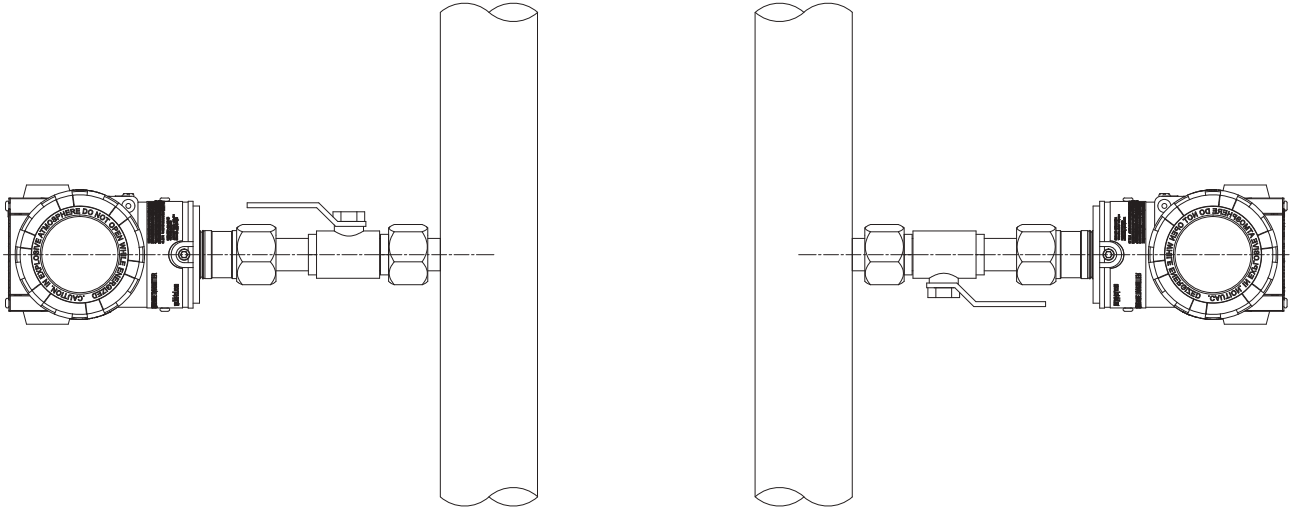

**Note:** For additional information on installation procedure for nut sleeve insertion, refer to the detailed manual.

## 11. Error Messages

The Tek-Thermal 1700B Thermal Mass Flowmeter display can also indicate the error codes. The following error codes are displayed:

Error Code	Problem	Repair
Err-003	Temperature Sensor Disconnected	Check Temperature Sensor
Err-004	Pressure Sensor Disconnected	Check Pressure Sensor
Err-005	About to Over Total Flow	This is a Reminder Message
Err-006	Display Value Over Limit	The Value is Over the Physical Limit of the Display
Err-013	Button Pressed for Too Long	Check the Button Circuit
Err-014	Reset Code Setting Failed	Check EEPROM
Err-015	Reset Digital Setting Failed	Check EEPROM
Err-016	Read Total Flow Error	Check EEPROM
Err-017	Wrong Temperature Calibration Setting	Check the Record of Temperature Calibration
Err-018	Wrong Pressure Calibration Setting	Check the Record of Pressure Calibration
Err-020	Incorrect Flow Rate Limit Setting	Check the Flow Rate Limit Setting
Err-023	Communication Connection Error	Check the Communication Link
Err-026	Pulse Equivalent is Set Too High	Reset D017
Err-027	Pulse Equivalent is Set Too Low	Reset D017

**Note:** : For more information on safety, troubleshooting, and repair, refer to the detailed manual.

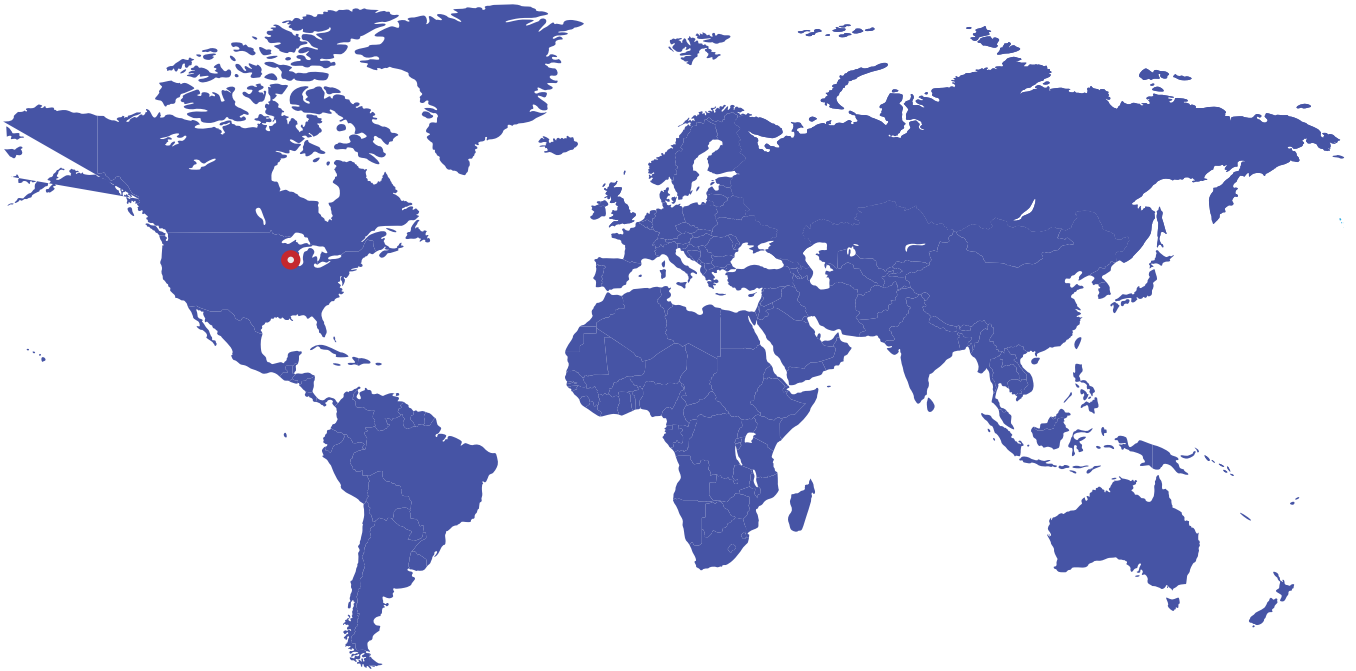

796 Tek Drive  
Crystal Lake, IL 60014  
USA

Tel: +1 847 857 6076

Fax: +1 847 655 6147

Email: [tektrol@tek-trol.com](mailto:tektrol@tek-trol.com)

[www.tek-trol.com](http://www.tek-trol.com)