



TEK-THERMAL 1700B ***Thermal Mass Flowmeter***

Instruction Manual

Document Number: IM-1700B



www.tek-trol.com

NOTICE

Read this manual before working with the product. For personal and system safety, and for optimum product performance, make sure you thoroughly understand the contents before installing, using, or maintaining this product.

For technical assistance, contact

Customer Support

796 Tek-Drive

Crystal Lake, IL 60014

USA

Tel: +1 847 857 6076, +1 847 655 7428

© **COPYRIGHT Tek-Trol LLC 2021**

No part of this publication may be copied or distributed, transmitted, transcribed, stored in a retrieval system, or translated into any human or computer language, in any form or by any means, electronic, mechanical, manual, or otherwise, or disclosed to third parties without the express written permission. The information contained in this manual is subject to change without notice.

Table of Contents

1	Safety Instructions	3
1.1	Intended Use	3
1.2	Certification	3
1.3	Safety Instructions from the Manufacturer	3
1.3.1	Disclaimer	3
1.3.2	Product Liability and Warranty	3
1.3.3	Information Concerning the Documentation	3
1.4	Safety Precautions	4
1.5	Packaging, Transportation, and Storage	5
1.5.1	Packaging	5
1.5.2	Transportation	5
1.5.3	Storage	5
1.6	Nameplate	6
2	Product Description	7
2.1	Introduction	7
2.2	Measuring Principle	7
2.3	Specifications	8
2.4	Dimensional Drawings	8
2.5	Model Chart	9
3	Installation	10
3.1	Selecting the Installation Location	10
3.1.1	Standard Installation	11
3.1.2	Installation for bend pipeline is at upstream or downstream	11
3.1.3	Installation for bend pipeline that may cause turbulence in the upstream or downstream	11
3.1.4	Installation when valves or pressure controller or any other device may cause turbulence in the upstream or downstream of the flowmeter	12
3.1.5	Installation for pipe expander	12
3.1.6	Installation for pipe reducer	12
3.2	Requirement on Insertion Direction	13
3.2.1	On a horizontal pipeline, normal air or gas	13
3.2.2	On a horizontal pipeline, high humidity air or wet natural gas	14
3.2.3	On a vertical pipeline, when the density of the gas is higher than air	14
3.3	Installation Procedure	15
3.3.1	Nut Sleeve Insertion	15
4	Electrical Connection	18
4.1	Grounding of Measuring Device	18
4.2	Power and Signal Connection	19
4.2.1	Wiring for 3-Wire Pulse Output	19
4.2.2	Wiring for 3-Wire HART with 4 to 20 mA	20
4.2.3	Wiring for 4-Wire HART with 4 to 20 mA	20
4.2.4	Wiring for RS485	20
5	Operation	21
5.1	Local Operation and Display	21
5.1.1	Multi-functional LCD Display	22
5.1.2	Total Flow on Display	23
5.2	Parameter Setting	24
5.2.1	Code Setting	24

5.2.1.1	Code Setting Address	25
5.2.2	Digital Setting	28
5.2.2.1	Digital Setting Address	29
5.2.3	Example of Setting	30
5.2.4	Password Setting	30
5.3	Bluetooth Access	31
5.3.1	How to download the application	31
5.3.2	Access the application	32
5.3.3	Utilize the application	32
6	Communication	33
6.1	RS485 Modbus	33
6.2	Address of the Displayed Date	33
6.3	Address of Code Setting	33
7	Maintenance	35
7.1	Sensor Cleaning	35
7.2	Remove transmitter circuit board	35
8	Troubleshooting	36
8.1	Self-Diagnostic Functions	37

1 Safety Instructions

1.1 Intended Use

Tek-Thermal 1700B is specially designed for air and N₂ applications, such as compressed air, venting air, aeration, process protection N₂, and combustion air.

1.2 Certification

General purpose IP67/NEMA 4X

1.3 Safety Instructions from the Manufacturer

1.3.1 Disclaimer

The manufacturer will not be held accountable for any damage that happens by using its product, including, but not limited to direct, indirect, or incidental and consequential damages.

Any product purchased from the manufacturer is warranted in accordance with the relevant product documentation and our Terms and Conditions of Sale.

The manufacturer has the right to modify the content of this document, including the disclaimer, at any time for any reason without prior notice, and will not be answerable in any way for the possible consequence of such changes.

1.3.2 Product Liability and Warranty

The operator shall bear authority for the suitability of the device for the specific application. The manufacturer accepts no liability for the consequences of misuse by the operator. Wrong installation or operation of the devices (systems) will cause the warranty to be void. The respective Terms and Conditions of Sale, which forms the basis for the sales contract shall also apply.

1.3.3 Information Concerning the Documentation

To prevent any injury to the operator or damage to the device it is essential to read the information in this document and the applicable national standard safety instructions. This operating manual contain all the information that is required in various stages, such as product identification, incoming acceptance and storage, mounting, connection, operation and commissioning, troubleshooting, maintenance, and disposal.

1.4 Safety Precautions

You must read these instructions carefully prior to installing and commissioning the device. These instructions are an important part of the product and must be kept for future reference. Only by observing these instructions, optimum protection of both personnel and the environment, as well as safe and fault-free operation of the device can be ensured.

For additional information that are not discussed in this manual, contact the manufacturer

Warnings and Symbols Used

The following safety symbol marks are used in this operation manual and on the instrument.



WARNING

Indicates a potentially hazardous situation which, if not avoided, could result in death or serious injury



CAUTION

Indicates a potentially hazardous situation which, if not avoided, may result in minor or moderate injury. It may also be used to alert against unsafe practices.



NOTE

Indicates that operating the hardware or software in this manner may damage it or lead to system failure.

1.5 Packaging, Transportation, and Storage

1.5.1 Packaging

The original package consists of

1. Tek-Thermal 1700B Thermal Mass Flowmeter
2. Documentation



i NOTE

Unpack and check the contents for damages or signs of rough handling. Report damage to the manufacturer immediately. Check the contents against the packing list provided.

1.5.2 Transportation

- Avoid impact shocks to the device and prevent it from getting wet during transportation.
- Verify local safety regulations, directives, and company procedures with respect to hoisting, rigging, and transportation of heavy equipment.
- Transport the product to the installation site using the original manufacturer's packing whenever possible.

1.5.3 Storage

If this product is to be stored for a long period of time before installation, take the following precautions:

- Store your product in the manufacturer's original packing used for shipping.
- Storage location should conform to the following requirements:
 - Free from rain and water
 - Free from vibration and impact shock
 - At room temperature with minimal temperature and humidity variation
- Before storing a used flowmeter remove any fluid from the flowmeter line completely. Properties of the instrument can change when stored outdoors.

1.6 Nameplate

The nameplate lists the order number and other important information, such as design details and technical data



NOTE

Check the device nameplate to ensure that the device is delivered according to your order. Check for the correct supply voltage printed on the nameplate.

Tek-Thermal Flowmeter

Model	<input type="text" value="1700B"/>	Accuracy	<input type="text"/>
Flow Range	<input type="text"/>	Output	<input type="text"/>
Pressure	<input type="text"/>	Temperature Range	<input type="text"/>
Power Supply	<input type="text"/>	Size	<input type="text"/>
Meter Factor	<input type="text"/>	S/N	<input type="text"/>

2 Product Description

This section covers the reference and specification data, as well as ordering information.

2.1 Introduction

Tek-Thermal 1700B Thermal Mass Flowmeters, also known as the thermal dispersion or immersible mass flowmeters, are the precision instruments to measure mass flow of fluid flowing in a closed channel like a pipe or duct. Tek-Thermal 1700B is specially designed for air and nitrogen (N_2) applications. It has the more compact design. It has a small enclosure and thin insertion probe tube. It is used in high-pressure applications.

2.2 Measuring Principle

The Tek-Thermal 1700B measures the gas mass flow based on Thermal Diffusion theory. It has two RTD (Resistance temperature Detector) sensors. One sensor measures the velocity of gas flow (R_h) and the other sensor detects the temperature shift of gas flow (R_{mg}). When there are two RTDs in the gas flow, R_h will be heated and R_{mg} will sense the temperature difference. As the velocity of gas flow increases, more heat will dissipate and so the temperature read by R_h will decrease.

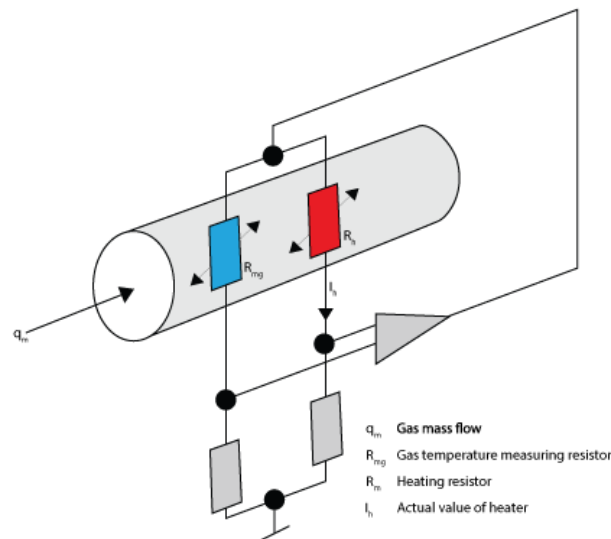

Tek-Thermal 1700B Thermal Mass Flowmeter design is based on constant power measuring method, thus the RTD is heated on a consistent power and will be more durable and stable. Due to that, Tek-Thermal 1700B has less problem of zero-off which may cause a function failure of RTD due to overheating the term.

2.3 Specifications

Media capability	Air, Nitrogen (N ₂)
Pipe diameter	1" to 20"
Flow velocity range	2 to 200 ft/sec or 1 to 100 ft/sec or 3 to 300 ft/sec
Accuracy	±0.5% FS
Maximum Pressure	232 PSI
Temperature of medium	-40°F to 302°F (-40°C to 150°C)
Power supply	13.5 to 42 VDC
Response time	1 second
Output	4 to 20mA and Pulse standard
Communication	Modbus RS485 or HART optional
Display Indication	Mass flow, Volume flow in normal condition, Total flow, Temperature of medium, Velocity
Ingress Protection	IP65

2.4 Dimensional Drawings

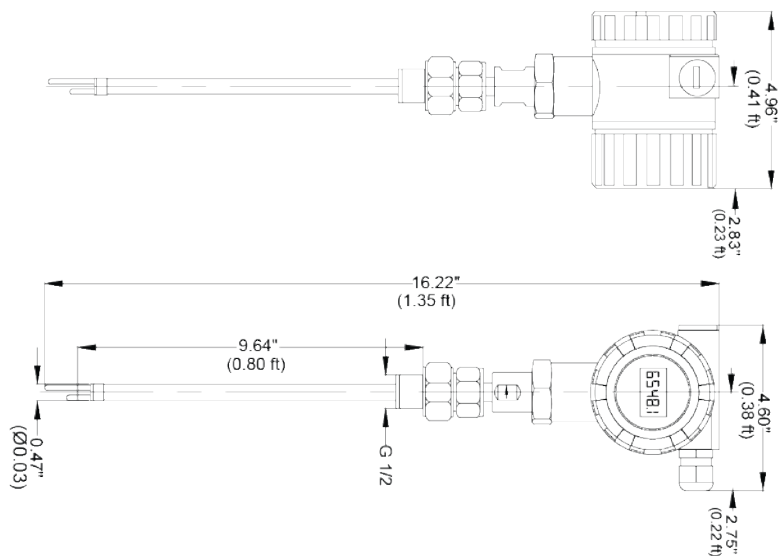

3 Installation

This section covers instructions on installation and commissioning. Installation of the device must be carried out by trained, qualified specialists authorized to perform such works.



CAUTION

- When removing the instrument from hazardous processes, avoid direct contact with the fluid and the meter
 - All installation must comply with local installation requirements and local electrical code
-

3.1 Selecting the Installation Location

The flowmeter is designed to withstand the severe environmental conditions. However, to ensure stable and accurate operation, observe the following precautions when selecting an installation location.

- **Ambient Temperature**
Avoid locations subject to wide temperature variations or a significant temperature gradient. If the location is exposed to radiant heat from plant equipment's, provide adequate thermal insulation and/or ventilation.
- **Ambient Atmosphere**
Avoid installing the transmitter in a corrosive atmosphere. If the transmitter must be installed in a corrosive atmosphere, there must be adequate ventilation as well as measures to prevent intrusion or stagnation of rain water in conduits.
- **Shock and Vibration**
Select an installation site with minimum shock and vibration (although the transmitter is designed to be relatively resistant to shock and vibration).

3.1.1 Standard Installation

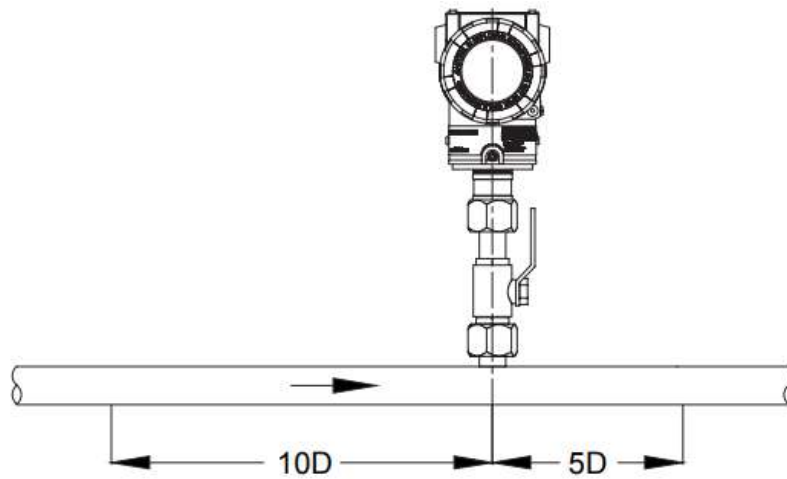

3.1.2 Installation for bend pipeline is at upstream or downstream

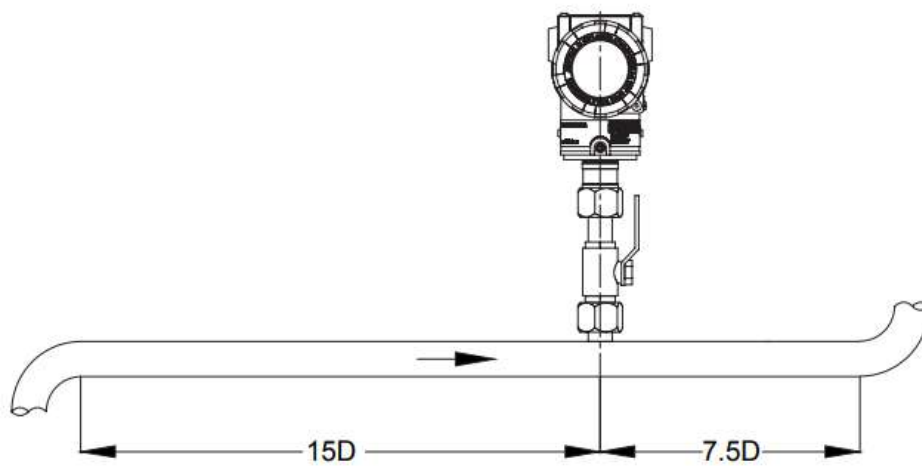

3.1.3 Installation for bend pipeline that may cause turbulence in the upstream or downstream

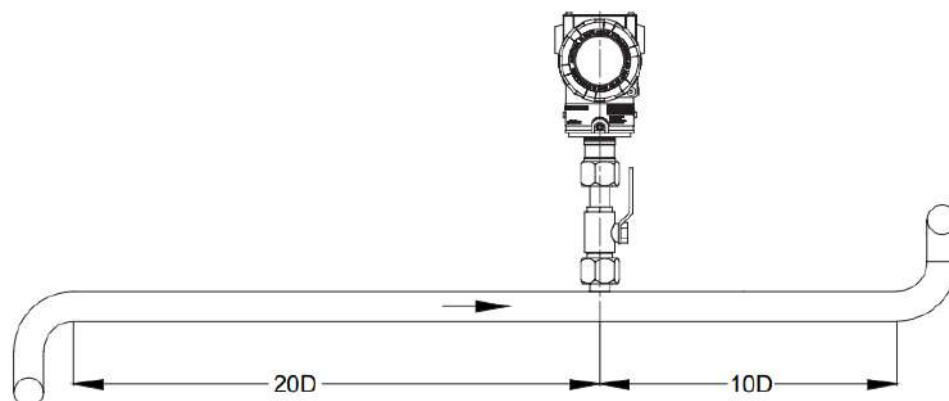

3.1.4 Installation when valves or pressure controller or any other device may cause turbulence in the upstream or downstream of the flowmeter

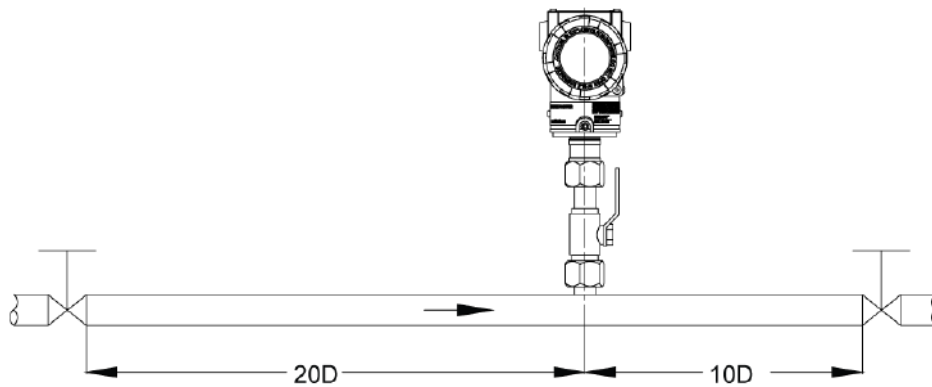

3.1.5 Installation for pipe expander

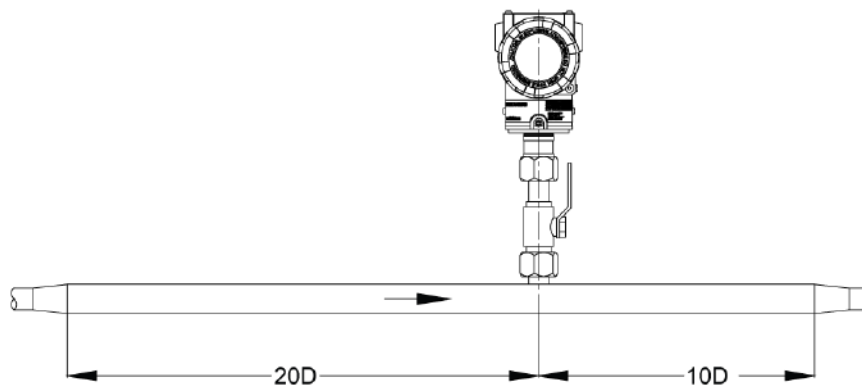

3.1.6 Installation for pipe reducer

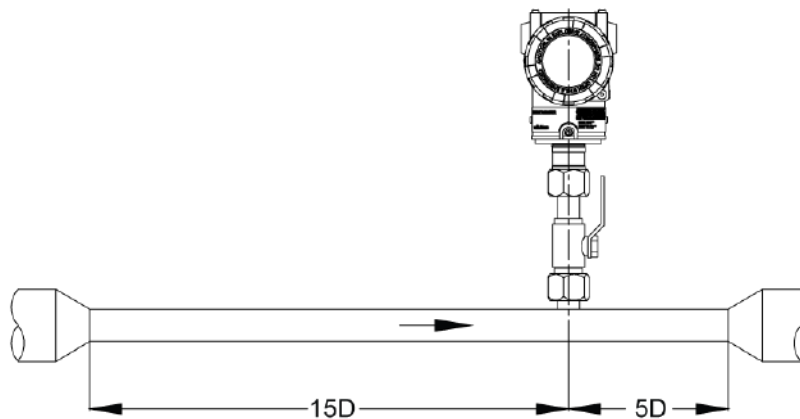

3.2 Requirement on Insertion Direction

3.2.1 On a horizontal pipeline, normal air or gas

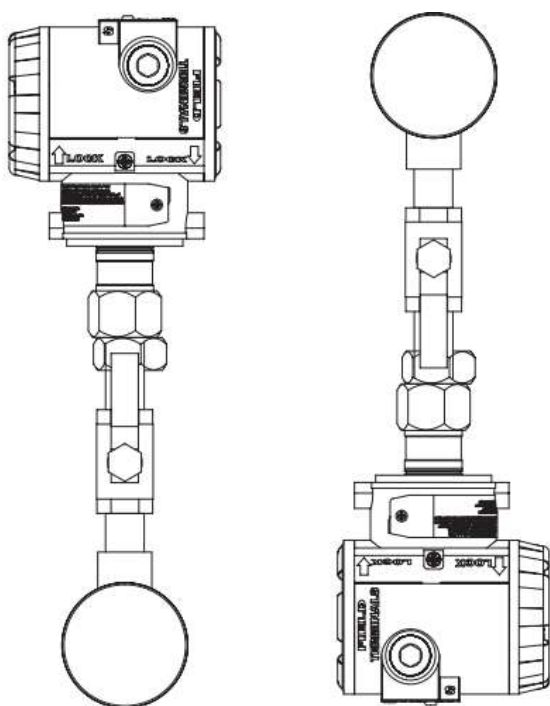

Above or under the pipeline

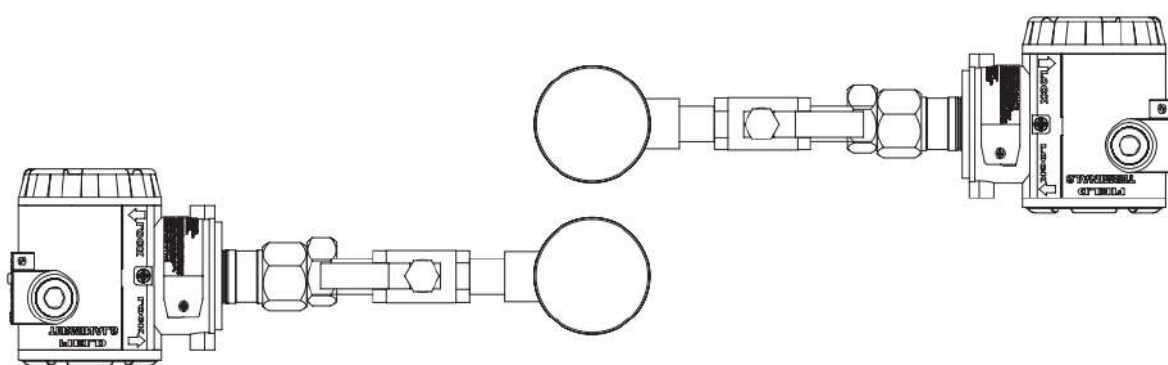

Side of the pipeline

3.2.2 On a horizontal pipeline, high humidity air or wet natural gas

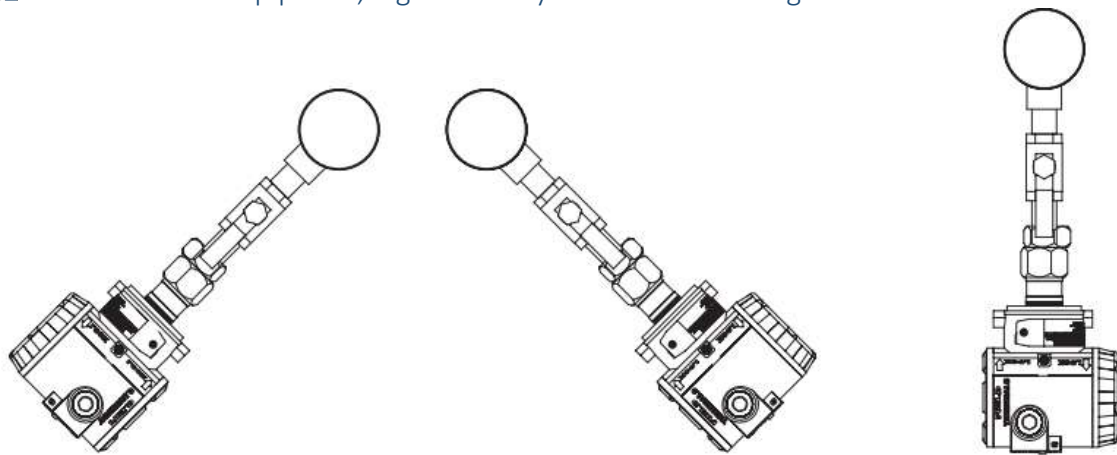

45° under the pipeline or just under the pipeline

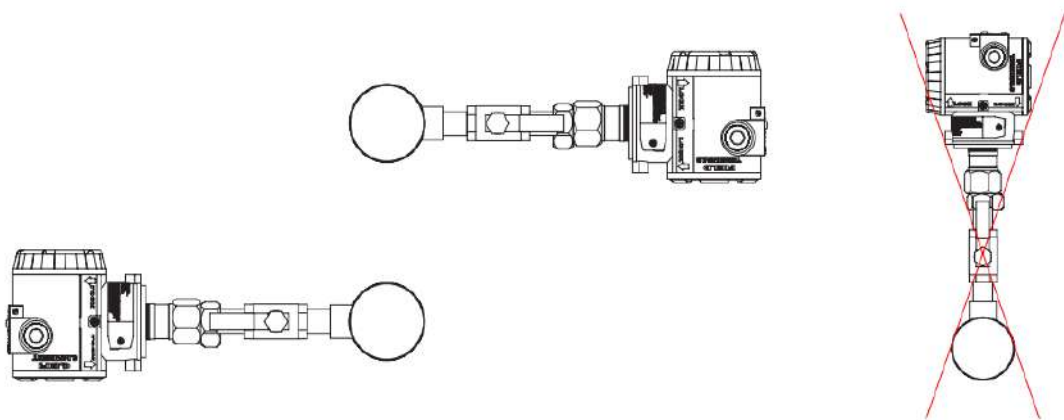

On the side of the pipe. Not recommended to install the meter above the pipeline

3.2.3 On a vertical pipeline, when the density of the gas is higher than air

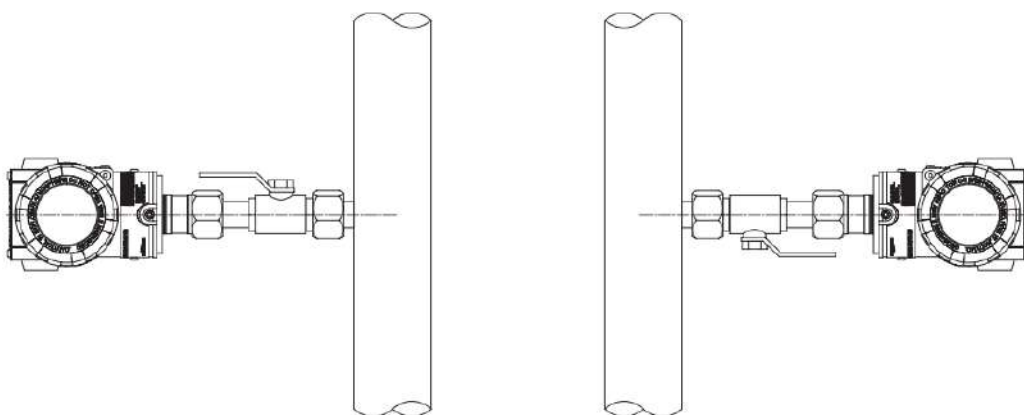

3.3 Installation Procedure

3.3.1 Nut Sleeve Insertion

1. Use cutting torch or sharp cutting tool to tap into the pipe. The pipe opening must be at least 0.5 inch (0.04 ft) in diameter (Do not insert sensor probe through a smaller hole)
2. Remove the burrs from the tap and sharp edges may causes flow profile disturbance that can affect the accuracy of flowmeter
3. Weld the MNPT $\frac{1}{2}$ " socket (Part No.1) on the open hole. The correct insertion depth places the centreline of the sensor access hole in probe at the pipe line's centreline

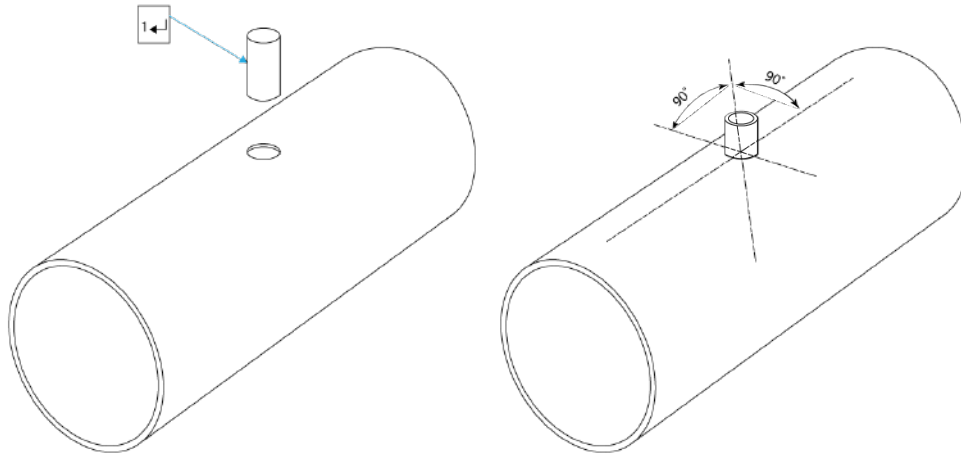

4. Bolt the $\frac{1}{2}$ " ball (isolation) valve (Part No.2) with FNPT threads on both ends of the socket. Seal the thread connection with thread sealant. The lever on the ball valve should be up when the valve is open.

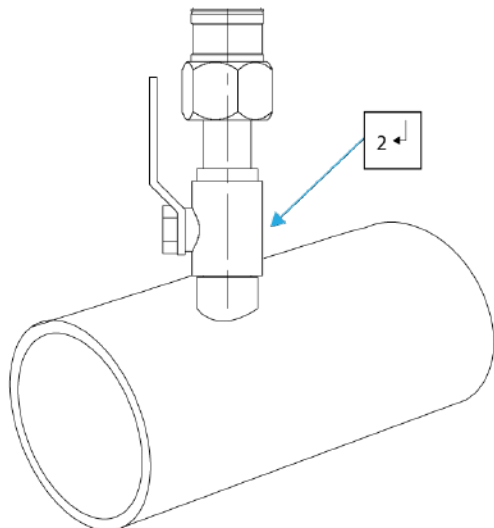

5. Insert the sensor probe through the ball valve (isolation valve) into the pipe. The correct insertion depth places the sensor at the pipe's centreline.
6. Calculate the insertion depth of the sensor probe,

$$S = \frac{A}{2} + B + C$$

Where,

A=Inner diameter of the pipeline

B=Thickness of the pipe line

C=The distance between the top of the pipeline and the upper end of the nut when the nut is fixed

7. connect the sleeve (Part No.3) on the meter and the ball valve (isolation valve), seal the thread connection part with thread sealant. Tighten the nut (Part No.4) with wrench.

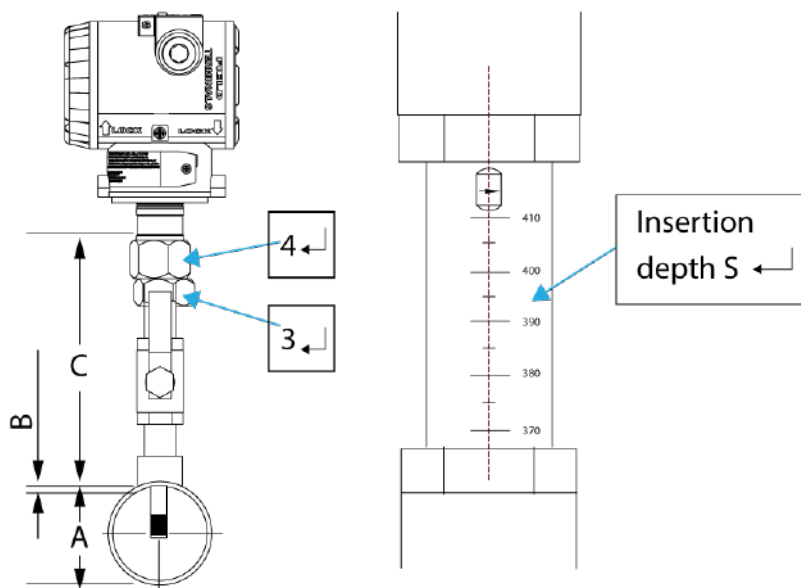

8. Adjust the direction of the flowmeter, make sure the direction mark on the probe (Part No.5) is pointing to the direction as the flow goes.

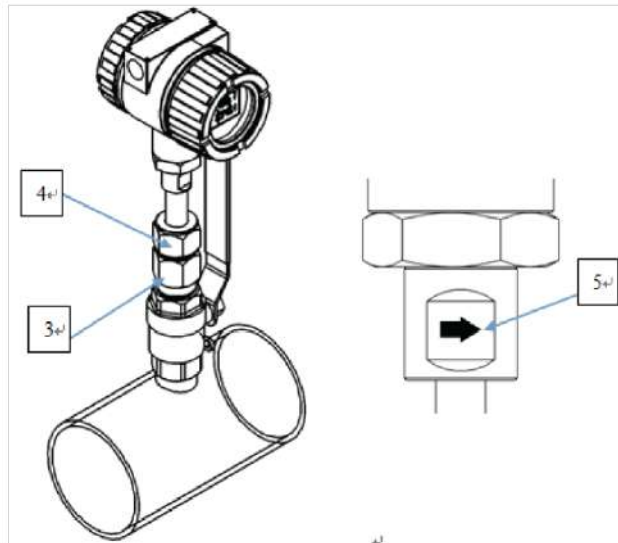

NOTE

If flow rate higher than 66 lb.ft/sec (90Nm/s) or pipe size larger than 8" (DN400), will require 19mm diameter probe, mounted in 1" ball valve and 1" socket and 22mm hole

4 Electrical Connection

This section covers the all electrical connection requirement. Electrical connection of the device must be carried out by trained, qualified specialists authorized to perform such work by the installation site.



WARNING

- Connect all electrical cables when the power is switched off. If the device does not have switch-off elements, then, overcurrent protection devices, lightning protection and/or energy isolating devices must be provided by the customer.
 - The device must be grounded to a spot in accordance with regulations in order to protect personnel against electric shocks.
-



NOTE

- When using the measuring device in hazardous areas, installation must comply with the corresponding national standards and regulations and the Safety Instructions or Installation or Control Drawings.
-

4.1 Grounding of Measuring Device

Tek-Thermal 1700B Thermal Mass Flowmeter the power supply of signal processing circuit is transferred from outside power supply by an isolation type DC-DC transmitter with advanced grounding technology. The field frequency interference can be isolated. The “V” terminal of power supply should not be connected to the ground. When

Tek-Thermal 1700B is used in the strong interference environment, the shell should be clean and connect to the earth through the cable, so that interference can be eliminated.

4.2 Power and Signal Connection

It has AC and DC power options. Supply power must be 13.5 to 42 VDC .

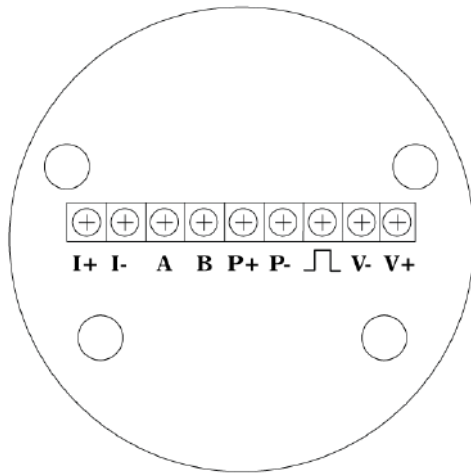

V +	Power Supply +
V -	Power Supply -
	Pulse Output
A+	RS485 Communication +
B-	RS 485 Communication -
I+	Current +
I-	Current -
P+	Pressure Transmitter +
P-	Pressure Transmitter -

4.2.1 Wiring for 3-Wire Pulse Output

3-wire pulse output requires a power source of 13.5 to 42 VDC. Tek-Thermal 1700B use a current pulse output with 50% duty ratio. Add resistor between and "V-", the resistance should be within 500Ω to 1000Ω, and power consumption should be no less than 0.5W

***Note:- Pulse Output:** Active(Pulse, V-), **4-20 mA output:** Passive(I+,I-), **Remarks for Pulse Output:** with/Without 250 ohms resistor across Pulse &V- terminals, **Remarks for 4-20 mA output:** External 24VDC to I+.connect PLC/Multimeter between I- and -Ve of power supply, **Diagrams for Pulse:** Active, **Diagrams for 4-20mA:**

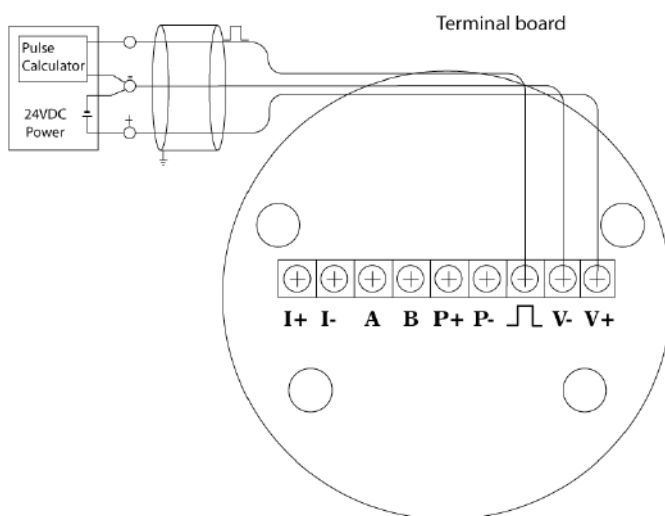

4.2.2 Wiring for 3-Wire HART with 4 to 20 mA

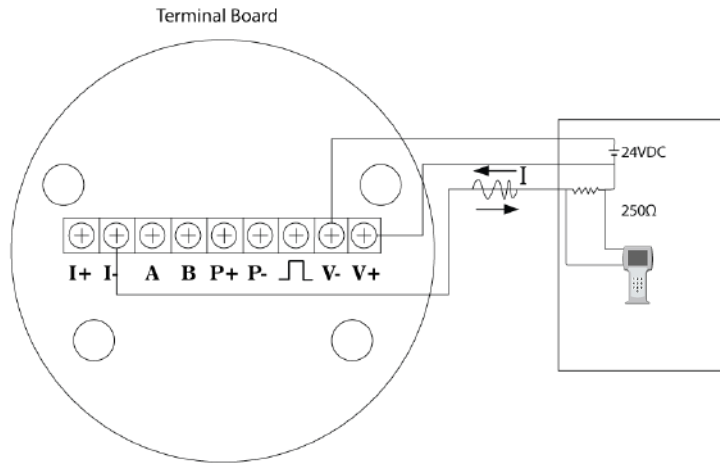

4.2.3 Wiring for 4-Wire HART with 4 to 20 mA

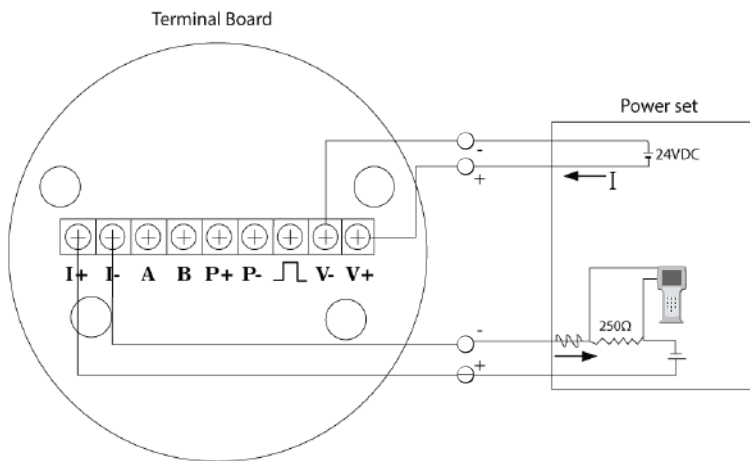

4.2.4 Wiring for RS485

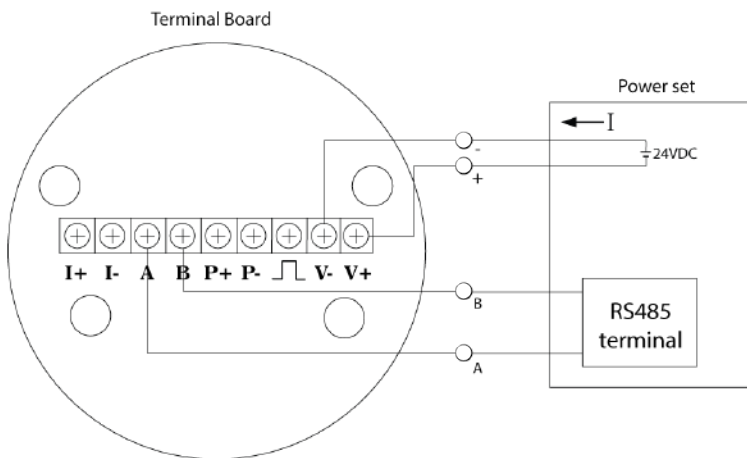



5 Operation

This section covers operation techniques and guidelines.

5.1 Local Operation and Display

Tek-Thermal 1700B provide local display and setting, can display several variables on the local multifunctional LCD display. It has 3 buttons used for configuration. The local display enables you to read all important parameters directly at the measuring point and configure the device using the function matrix. The LCD display indicates output.

Tek-Thermal 1700B has three buttons are placed on the top of the display, which are  used as L-R button,  used as U-D button,  used as Enter button.

- Pressing the L-R button will move the menu selection to the left/right, or the data entry field to the left/right if updating a menu value
- Pressing the U-D button will move the menu selection up/down, or increment the data entry field if you are updating a menu value
- Pressing enter button to save the current value

All the “Digital setting” and “Code Setting” of the flowmeter is made through these 3 buttons.

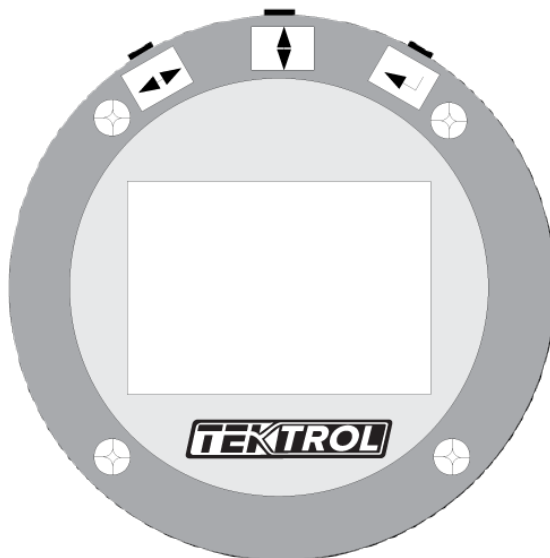

5.1.1 Multi-functional LCD Display

Tek-Thermal 1700B Thermal Mass Flowmeter has a display to indicate temperature, flow rate, total flow and more parameters.

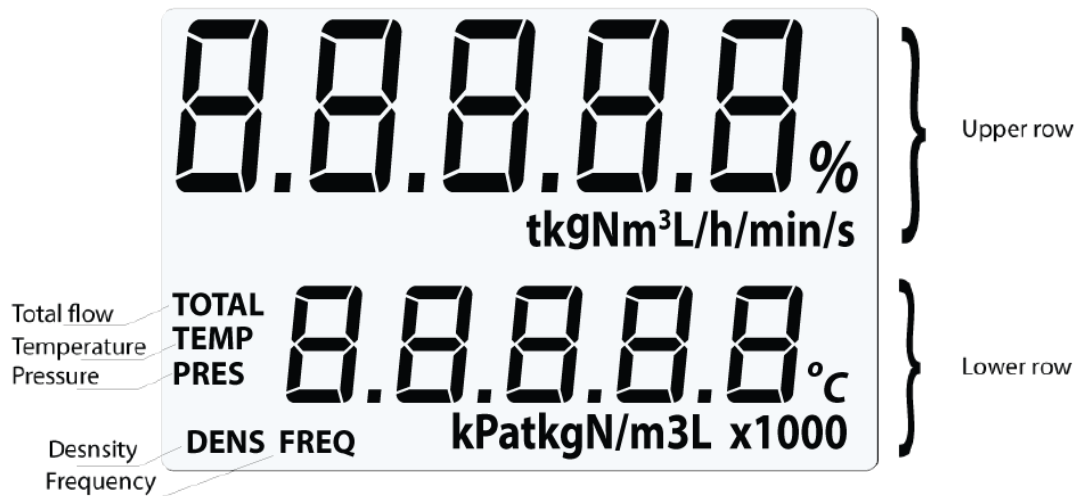

The LCD display has 2 areas to display the content, the upper row, the lower row. The upper row displays the flow rate, mass flow, and standard flow rate. Below the upper row displays the unit of the variable displayed in the upper row. The lower row displays other variables, such as frequency, pressure, temperature, density and total flow. And below the lower row displays the unit of the variable displayed in the lower row.



Tek-Thermal 1700B Multi-Variable version can also display temperature. Users can switch the parameter displayed on LCD by using the buttons and the next parameter will be displayed for 30 seconds. Users can also fix the lower row to display a parameter consistently. You can also set the lower row to display several variables in circular turn.



5.1.2 Total Flow on Display

The lower row of the flowmeter displays total flow. Tek-Thermal 1700B can display 9 digits left to decimal point and 3 digits right to the decimal point. When more than six digit displays on LCD, the total flow reading will be displays two times. First displays the right digits and then displays the left digits. The left digits display with a mark "x1000". By using L-R button you can switch the left and the right digits on LCD.



To check the right digits now, press the "L-R button", the display will be



According to picture, the total flow is 569864.581 kg

5.2 Parameter Setting

The Tek-Thermal 1700B has three modes as below

- Working Mode
- Setting Mode
- Calibration Mode

5.2.1 Code Setting

- In working mode, press the “Enter” button and “U-D” button at the same time to enter in the code setting

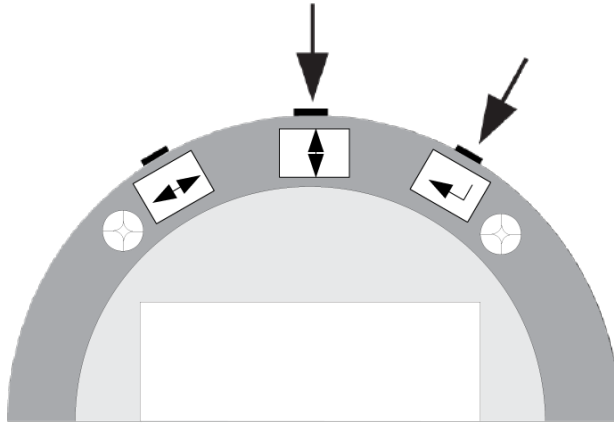

- In the code setting first row displays the reference number and lower row displays the content of this parameter
- Use the “L-R” button to move to the next digit and use “U-D” to cycle through the number. Once the correct value has been entered, hit the “Enter” button to save current value.
- The C01=02, that is set the pre-heating time to 2 seconds.



- Press the “Enter” button and “U-D” button at the same time to exit the code setting menu

5.2.1.1 Code Setting Address

Code setting address	Item	Code	Description of code
C01	Start-up time	01 to 99	Set the start-up time within 1 to 99 seconds Liquid
C02	Density Type	00	Display standard volume flow rate
		01	Density pre-set, display mass flow
		02	Display actual flow rate
C03	Pulse Output Type	00	pulse output off
		01	Frequency output
		02	Pulse equivalent output
C06	Pulse output parameter	00	Flow rate
		01	Temperature
		02	Pressure
		03	Total Flow
C07	Damping	01 to 16	1 to 16 seconds
C08	Instrument number	00 to 99	For Modbus
		00 to 15	For HART communication
C09	Baud rate	01	1200 no parity 1 stop bit
		02	1200 even parity 1 stop bit
		03	2400 no parity 1 stop bit
		04	2400 even parity 1 stop bit
		05	4800 no parity 1 stop bit
		06	4800 even parity 1 stop bit
		07	9600 no parity 1 stop bit
		08	9600 even parity 1 stop bit
		09	19200 no parity 1 stop bit
		10	19200 even parity 1 stop bit
		11	1200 odd parity 1 stop bit
		12	2400 odd parity 1 stop bit
		13	4800 odd parity 1 stop bit
		14	9600 odd parity 1 stop
		15	19200 odd parity 1 stop bit
		16	38400 no parity 1 stop bit
		17	38400 even parity 1 stop bit
		18	38400 odd parity 1 stop bit
		19	57600 no parity 1 stop bit
		20	57600 even parity 1 stop bit
		21	57600 odd parity 1 stop bit
		22	115200 no parity 1 stop bit
23	115200 even parity 1 stop bit		
24	115200 odd parity 1 stop bit		

C10	Time unit for flow rate	00	/s
		01	/min
		02	/h
C11	Mass unit	01	Kg
		02	Ton
		03	Lb
C12	Volume unit for flow rate	01	m ³
		02	L
		03	ft ³
		04	US gal
		05	UK gal
C13	Pressure unit	00	kPa (Absolute Pressure)
		01	kPa (Gauge pressure, minus sign for negative pressure)
		02	KPa (Gauge pressure)
		03	MPa (Absolute pressure)
		04	MPa (Gauge pressure, minus sign for negative pressure)
		05	MPa (Gauge pressure)
		06	PSI (Absolute pressure)
		07	PSI (Gauge pressure, minus sign for negative pressure)
		08	PSI (Gauge pressure)
		09	Bar (Absolute pressure)
		10	Bar (Gauge pressure, minus sign for negative pressure)
11	Bar (Gauge pressure)		
C14	Temperature unit	01	°C
		02	°F
		03	K
C15	Right digits number for total flow	00 to 05	00 : No right digits for total flow
			01 to 05 : 1 to 5 right digits for total flow
C25	Password for setting	00	Password protection off
		01	Password protection on
C26	Fixed max flow	00	Fixed max flow off
		011	Fixed max flow on. (If the flow rate measured is over the setting of D039, the display will show the reading as D039)
C31	Time space for circle display	0 to 30	00 : circle display off
			1 to 30 : 1 to 30 seconds between the display of different parameter
C32	First parameter displayed in circle display	00 to 05	00 : circle display off
			01 to 05 : see chart 4.1
C33	Second parameter	00 to 05	00 : circle display off

	displayed in circle display		01 to 05 : see chart 4.1
C36	Last parameter displayed in circle display	00 to 05	Same as above
C40	The date sequence of IEEE format float of Modbus	01	Lower 16 bits address in front, the lower 8 bits in the 16 bits address in front
		02	Higher 16 bits address in front, the Higher 8 bits in the 16 bits address in front
		03	Lower 16 bits address in front, the higher 8 bits in the 16 bits address in front
		04	Higher 16 bits address in front, the lower 8 bits in the 16 bits address in front
C41	Shape of pipeline	00	Round pipeline (D: D010)
		01	Rectangle pipeline (L:D018 W:D019)
C47	Set password	00	Keep the password
		01	Change the pass word
C49	Status	00	Working status
		01	4 to 20mA output calibration statuses
		02	Flow rate calibration statuses
		03	Temperature calibration statuses
		04	Pressure calibration statuses
C50	Total flow reset	00	Reset total flow to 0
		01	Default
C60	Restore to backup date	06	Restore to backup date
C61	Save setting backup	16	Save current setting for backup
C80	Version No. of hardware		Read Only
C81	Version No. of software		Read Only
C82	Calibration date		Read Only
C83	Number of errors		Read Only
C84	Version No. of HART		Read Only
C86	Communication interface	00	Modbus Read Only
		01	HART Read Only
C87	Pressure sensor type	00	No pressure sensor Read Only
		01	Piezo Read Only
		02	Piezo Read Only
		03	4 to 20mA Read Only
		04	0 to 10mA Read Only
C88	Product ID No.		Read Only

5.2.2 Digital Setting

- To enter in to the digital setting, press “Enter” and “L-R” button at the same time.

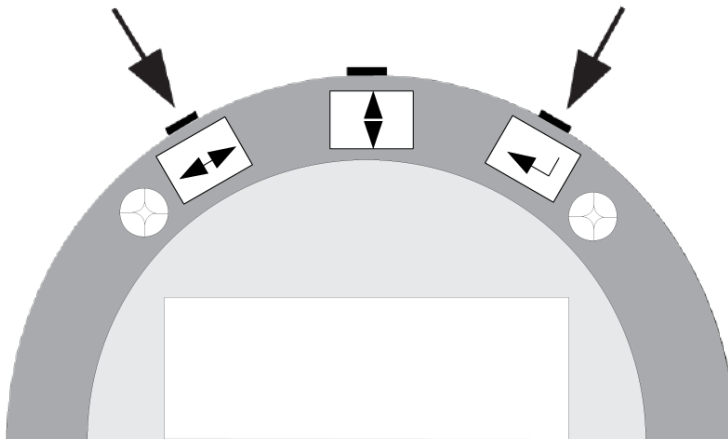

- The first row displays the reference number of digital setting and lower row display the content of this parameter
- Use the “L-R” button to move to the next digit and use “U-D” to cycle through the number. Once the correct value has been entered, hit the “Enter” button to save the current value
- In below picture, D001=1.60000, Max flow is 1.6 (unit according to another setting)



- Press the “Enter” button and “U-D” button at the same time to exit the code setting menu

5.2.2.1 Digital Setting Address

Digital setting address	Item	Code	Description of code
D001	Max flow rate	[-99999, 999999]	Unit is same as flow rate, Max/min flow rate of 4 to 20mA and 200 to 1000Hz output
D002	Min flow rate	[-99999, 999999]	
D003	Max frequency output	0.5 to 10000	The frequency output of max flow, unit is Hz
D004	Min frequency output	0.5 to 10000	The frequency output of min flow, unit is Hz
D005	Cut off small signal	[-99999, 999999]	Unit is same as flow rate
D008	K factor	[0 to 999999]	
D009	Density	[0 to 999999]	Unit is Kg/m ³
D010	Pipe size	[0 to 3281]	Unit is feet
D011	Max temperature (Unit as set in C14)	-99999 to 999999	The max frequency when temperature is output by frequency, 1000Hz for instance. The max current when temperature is output by current, 20mA for instance
D012	Min temperature (Unit as set in C14)	-99999 to 999999	The min frequency when temperature is output by frequency, 200Hz for instance. The min current when temperature is output by current, 4mA for instance
D013	Max pressure (Unit as set in C13)	-99999 to 999999	The max frequency when temperature is output by frequency, 1000Hz for instance. The max current when temperature is output by current, 20mA for instance.
14	Min pressure (Unit as set in C13)	-99999 to 999999	The min frequency when temperature is output by frequency, 200Hz for instance. The min current when temperature is output by current, 4mA for instance.
D015	Ambient pressure	0 to 999999	Unit according to setting
D017	Equivalent of pulse output	0 to 999999	Set the equivalent that one pulse output stands for Unit as C06

D018	Length of rectangle pipeline	0 to 3281	Unit is feet
D019	Width of rectangle pipeline	0 to 3281	Unit is feet
D030	Temperature of standard condition	0 to 20	Default temperature of standard condition is 20 °C
D033	Reference flow rate	0 to 999999	When measured flow rate is over calibrated max flow, will display/output the reference flow rate

5.2.3 Example of Setting

For insertion connection, measure air in 6" (DN0.5) pipe, density pre-set, unit displayed in kg/hr, flow range of 0 to 4000kg/hr, 200 to 1000Hz output

Code setting	Address	Code	Description
	C02	01	Density pre-set
	C03	01	Frequency output
	C06	00	Output parameter is flow rate
Digital setting	D009	1.2930	Density=1.293, air
	D008	1.000	Factor=1
	D001	5000	The flow rate for 1000Hz output
	D002	0	The flow rate for 200Hz output
	D010	150	Pipe size=150mm
	D003	1000	Max output frequency
	D004	200	Min output frequency

5.2.4 Password Setting

In code setting, set C47 to 01.

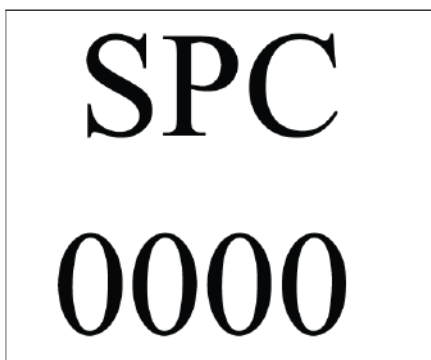

To set the new password, use “U-D” button to cycle through numbers and “L-R” button to move to the next digit. The user must have entered the password twice. If power is off once the password has been entered, hit “Enter” button to save the current password value.



5.3 Bluetooth Access

5.3.1 How to download the application

- Visit Apple’s application store
- Search “Tek-trol Bluetooth” or “Tek-Bluetooth” to find our app profile
- Download the application

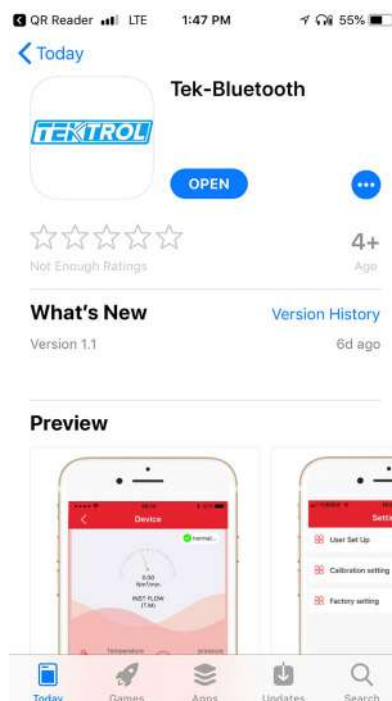

5.3.2 Access the application

- Open application
- Enter login information (ID: 20000000007, Verify code:341234)
- This will take you to “device list” where your phone will automatically sync with your product (you must be close enough)

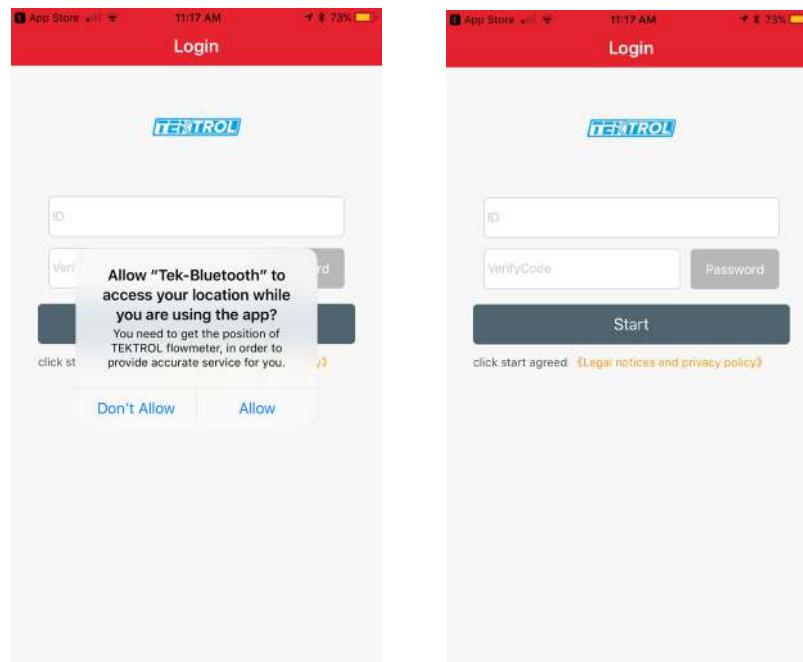

5.3.3 Utilize the application

Follow prompts and menu to navigate through the many features of our bluetooth application!

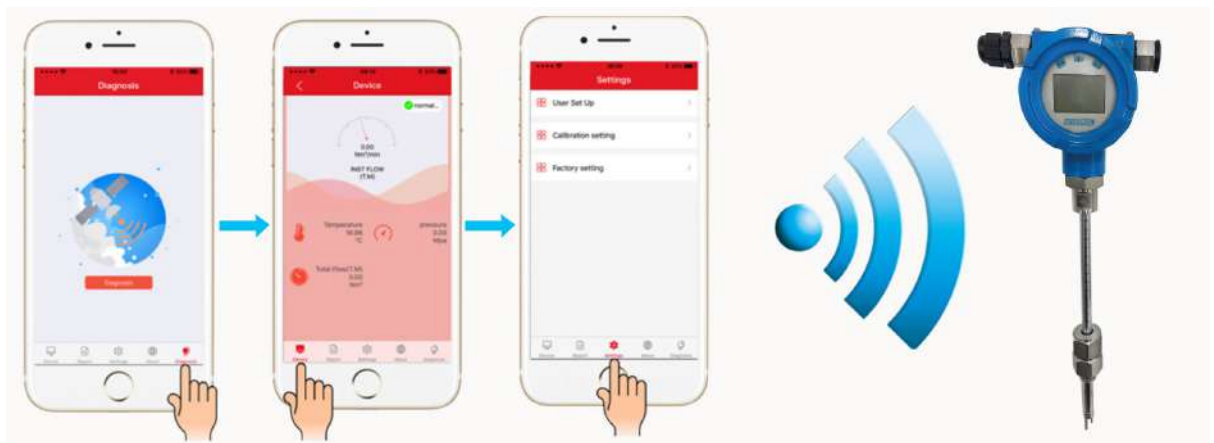

6 Communication

This section covers guidelines for setting up RS485 Modbus communication

6.1 RS485 Modbus

The communication interface should be RS485, the range of Baud rate should be 1200 to 115200. The wiring terminal is “A” and “B”. The communication should comply with MODBUS-RTU.

The combination of a communication signal: Address code - function code – data segment – CRC calibration code. The distance between two characters should not be longer than one character, or it will be considered as the beginning of a new message or the end of an old message. The message is combined with hexadecimal arrays.

6.2 Address of the Displayed Date

Register address	Usage	Nature	Date type
0 to 1	Flow rate	Read only	Float
2 to 3	Frequency	Read only	Float
4 to 5	Pressure	Read only	Float
6 to 7	Total Flow	Read only	Float

The displayable dates including flow rate, pressure, temperature and total flow, if the meter is not multi-variable version, then the reading of pressure and temperature will both be 0. The date of the parameters in above chart can be read by using function code 03 according to the address above and shifting.

6.3 Address of Code Setting

Register	Usage	Range	Nature	Date type
1000	Pre-heating time (warm up) C01	1 to 99	Read only	Short
1001	Density compensation C02	0 to 2	Read/Write	Short
1002	Method of pulse output	0 to 2	Read/Write	Short
1004	Output C05	0 to 2	Read/Write	Short
1005	Pulse output parameter	0 to 3	Read/Write	Short
1006	Damping C07	1 to 16	Read/Write	Short
1007	Instrument number C08	Hart (0 to 15) MB (1 to 99)	Read	Short
1008	Baud rate C09	1-24	Read	Short
1009	Unit of time C10	0-2	Read/Write	Short
1010	Mass unit C11	0-2	Read/Write	Short
1011	Volume unit C12	0-6	Read/Write	Short
1012	Pressure unit C13	0-11	Read/Write	Short
1013	Temperature	0-2	Read/Write	Short

	unit C14			
1014	Right digits number for total flow C15	0-5	Read/Write	Short
1030	Time of circle display C31	0-30	Read/Write	Short
1031	First parameter displayed in circle display C32	1-5	Read/Write	Short
1032	Second parameter displayed in circle display C33	0-5	Read/Write	Short
1033	Third parameter displayed in circle display C34	0-5	Read/Write	Short
1034	Fourth parameter displayed in circle display C35	0-5	Read/Write	Short
1035	fifth parameter displayed in circle display C36	0-5	Read/Write	Short
1039	Sequence of float C40	1-4	Read/Write	Short
1040	Shape of pipeline C41	0-1	Read/Write	Short
1042	The array length of moist control C43	5-50	Read/Write	Short
1048	Status C49	0-10	Read/Write	Short
1049	Total flow reset to 0 C50	0-1	Read/Write	Short

7 Maintenance

This section covers maintenance techniques and guidelines.

7.1 Sensor Cleaning

The sensor is insensitive to the small amount of dirt, but due to continuous use in the dirty environment will need to do the periodic cleaning.

Follow these instructions while cleaning the sensor

- Disconnect power supply from electronics
- Remove the sensor carefully from pipe
- Clean the sensor with water alcoholic solutions. Use soft brush or cotton bug for this purpose
- Mount the sensor in pipe and switch on the power supply

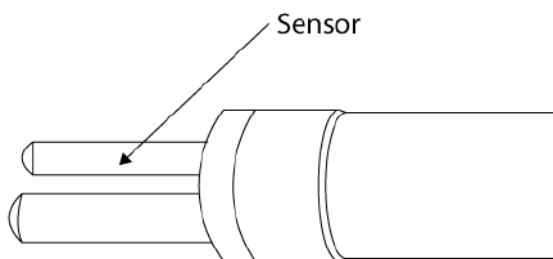

7.2 Remove transmitter circuit board

- Disconnect the power supply from electronics
- Remove the front cover of transmitter
- Loosen the 4 screws on the circuit board
- Remove all connections on circuit board and remove the board
- Place new circuit board and plug it
- Tighten the screws and place front cover

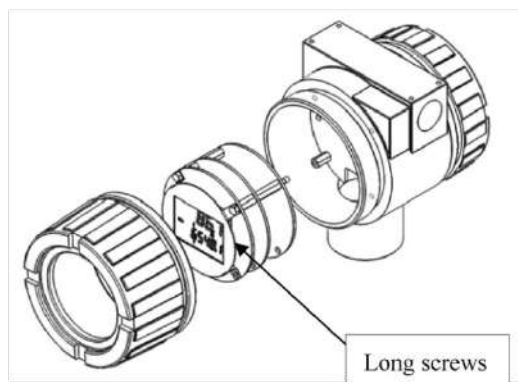

8 Troubleshooting

This section provides troubleshooting techniques for most common operating problems.

Before troubleshooting check the following:

- Wiring of power supply
- Meter's flow direction

Problem	Cause	Solution
Velocity measurement is erratic or fluctuating	Very erratic or non-uniform flow	Follow installation requirements
	Flowmeter installed with less than required minimum pipe diameters upstream and downstream of the sensor	Follow installation requirements
	Insertion sensor probe not mounted securely	Sensor probe must be mounted securely without vibration
	Earthing circuit loop	Check if wiring to the correct terminal
	Liquid contains in fluid	Install a water filter in upstream of the meter
	Sensor failure	Return to factory for evaluation
The measuring flow is too high or too low	Sensor is not inserted to the middle of the pipeline	Please fix the sensor in the middle of the pipeline
	The flowmeter is not vertical to the center line of the pipeline	Re-install the meter and make the probe vertical to the center line of the pipe line
No flow measured	The limit of small signal cut off is set too high	Set the small signal cut off limit to a lower and proper value
	The flow rate in pipeline is smaller than the lower limit of the meter	Check if there is high voltage instrument or high-frequency interference close to the flowmeter
	The flow rate in pipeline is larger than the higher limit of the meter	Sense the vibration on the pipeline by touch it with hand
	Flow profile distortion	Try to find another location for the meter
	Sensor failure	Return to factory for evaluation
	Transmitter failure	Return to factory for evaluation
	Extremely turbulent flow	Do not place the meter near a ventilator static mixer or valve

8.1 Self-Diagnostic Functions

Error code	Problem	Repair
Err-003	Temperature sensor disconnected	Check Temperature sensor
Err-004	Pressure sensor disconnected	Check pressure sensor
Err-005	About to over total flow	This is a reminding message
Err-006	Display value over limit	The value is over the physical limit of the display
Err-013	Button is pressed and hold for too long time	Check the button circuit
Err-014	Reset code setting failed	Check EEPROM
Err-015	Reset digital setting failed	Check EEPROM
Err-016	Read total flow error	Check EEPROM
Err-017	Temperature calibration setting is the wrong	Check the record of temperature calibration
Err-018	pressure calibration setting is the wrong	Check the record of pressure calibration
Err-020	Flow rate limit setting is incorrect	Check the flow rate limit setting
Err-023	Communication connection error	Check the communication link
Err-026	Pulse equivalent is set too high	Reset D017
Err-027	Pulse equivalent is set too low	Reset D017



https://eximpinternational.sharepoint.com/:b:/s/Marketing/EahHnscL6UVDhZQi92-hqFIBdMFqMIWlaY_mPhQMyllkwA?e=9MsVPB

TEKMATION LLC reserves the right to change the designs and/or materials of its products without notice. The contents of this publication are the property of TEKMATON and cannot be reproduced by any other party without written permission. All rights reserved. Copyright © 2017 TEKMATON LLC
DOCFEX/TIPS/ANLZ/16520/17008/02.3
TEKMATION LLC



www.tek-trol.com

Tek-Trol LLC

796 Tek Drive Crystal Lake,
IL 60014, USA

 +1 847-857-6076

 tektrol@tek-trol.com

 www.tek-trol.com

Tek-Trol is a fully owned subsidiary of TEKMATON LLC. We offer our customers a comprehensive range of products and solutions for process, power and oil & gas industries. Tek-Trol provides process measurement and control products for Flow, Level, Temperature & Pressure Measurement, Control Valves & Analyzer systems. We are present in 15 locations globally and are known for our knowledge, innovative solutions, reliable products and global presence.

Flow | Level | Temperature | Pressure | Valves | Analyzers | Accessories | TekValSys