



Technology Solutions

TEK-TEMP 2100A

Explosion-Proof Temperature Transmitter



TEMPERATURE

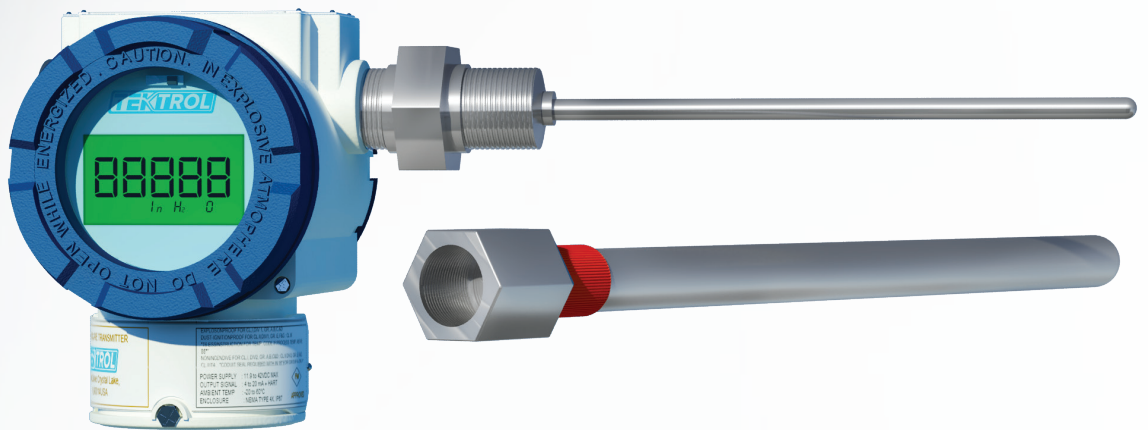

Introduction

Tek-Trol's Explosion-Proof Temperature Transmitter is a micro-processor based temperature transmitter, that has temperature sensors such as Thermocouple(T/C), Resistance Temperature Detector (RTD), milliVolt (mV), and Resistance. Tek-Temp 2100A Model is explosion-proof type and has high precision, better reliability, and uses a remote communication system. This transmitter is enabled in HART communication with Host, HHT (HART Hand-Held Terminal), or PC Configurator. The transmitter has various variables in host that is enabled to be changed, configured, and calibrated by users with the help of HHT.

Measuring Principle

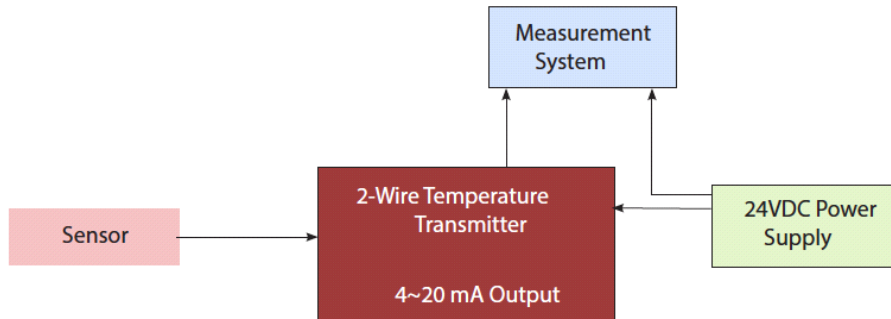

A temperature transmitter is typically connected to a 24 VDC power source. The temperature sensor such as RTD or Thermocouple measures the temperature of the medium. The output signal of the sensor is first modified into a standard format with the help of a Signal Conditioning processes such as Amplification, Isolation, Filtering, Linearization, and Excitation by the transmitter. The transmitter amplifies and converts the output to a high-level analog signal, usually a standard 4-20 mA signal. It then transmits the amplified signal to the control device by means of long cable runs.

Benefits

Superior Performance:

- High Accuracy: $\pm 0.1\%$ FS (at 68 °F (20 °C), mV input)
- Long-Term Stability

Flexibility:

- Selection of various T/C, RTD, mV, Ohm
- Data Configuration with HART® configurator or using Zero and Span buttons for device configuration.
- Also available with fieldbus

Reliability:

- Continuous Self Diagnostic Function (sensor, memory, communication)
- Automatic Compensation: Linearization of sensor input, ambient temperature compensation
- Fail-mode process function by hardware and software
- EEPROM Write Protection
- I/O Isolation: Grounded T/C input
- CE EMC Conformity Standards (EN50081-2, EN50082-2)

Other:

- Dual Compartment housing to separate receive electronics and field wiring and transmitter electronics.
- Good compatibility of the 4-20 mA output signal with most control systems
- No expensive wiring
- Easy to maintain
- Immune to the electromagnetic interference and radio frequency interference present in plants
- 5 digit LCD display for units in °C or °F

Applications

- Cement Industry
- Pharmaceutical Industry
- Food Processing Industry

Dimensional Drawing

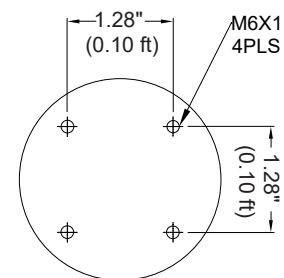
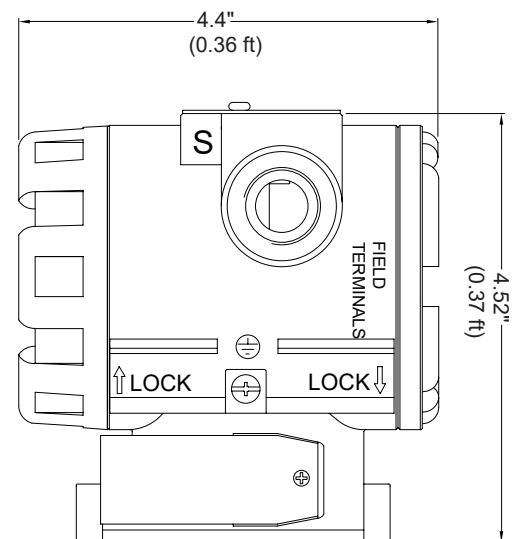
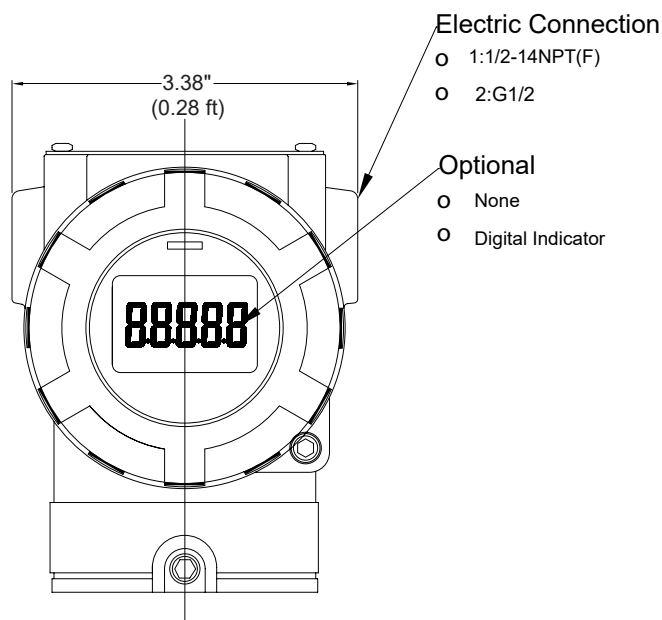

Specifications

Temperature Sensor Range and Accuracy

Table 1

Sensor Type	Sensor Reference	Input Range	Minimum Span	Digital Accuracy	D/A Accuracy of Span
RTD					
Pt-100	KSC 1603-1991 (a=0.00385) DIN	-328 to 1202 °F (-200 to 650 °C)	59 °F(15 °C)	±32.3 °F (±0.17 °C)	±0.03%
Pt-100	JISC 1604-1981 (a=0.00391)	-328 to 1202 °F (-200 to 650 °C)		±32.3 °F (±0.16 °C)	
Thermocouple					
NIST Type B	KSC1602-1982	212 to 3308 °F (100 to 1,820 °C)	482 °F (250 °C)	±33.38 °F (±0.77 °C)	±0.03%
NIST Type E		-328 to 1832 °F (-200 to 1,000 °C)		±32.36 °F (±0.20 °C)	
NIST Type J		392 to 2192 °F (200 to 1,200 °C)		±32.45 °F (±0.25 °C)	
NIST Type K		-328 to 2462 °F (-200 to 1,350 °C)		±32.63 °F (±0.35 °C)	
NIST Type N		392 to 2372 °F (200 to 1,300 °C)		±32.72 °F (±0.40 °C)	
NIST Type R		32 to 3200 °F (0 to 1,760 °C)		±33.08 °F (±0.60 °C)	
NIST Type S		32 to 3164 °F (0 to 1,740 °C)		±32.9 °F (±0.50 °C)	
NIST Type T		-328 to 752 °F (-200 to 400 °C)		±32.45 °F (±0.25 °C)	
Millivolt Input		-10 to 75 mV	2 mV	± 0.012 mV	
Ohm Input		0 to 340 Ω	20 Ω	± 0.3 Ω	

Note:

- 1) RTD input: a = 0.00385: KS, JIS, DIN, IEC, a=0.0039 : US.
- 2) Thermocouple input: KSC 1602-1982, JISC 1602-1981, ANSI MC96.1-1982
- 3) Digital accuracy for Type B is ±37.4 °F (± 3.0 °C) from 212 °F to 572 °F (100 °C to 300 °C)
- 4) Digital accuracy for Type K is ±32.9 °F (±0.50 °C) from -292 °F to -130 °F (-180 °C to -90 °C)

Table 2

Ambient Temperature Effects [per 33.80 °F (1 °C) change in ambient temperature]

	Sensor Type	Digital Accuracy	D/A Effect
RTD 2W, 3W, 4-Wire	Pt 100 (a = 0.00385)	32.005 °F (0.003 °C)	0.002% of Span
	Pt 100 (a = 0.003916)		
Thermocouple	NIST Type B	32.082 °F (0.046 °C)	
	NIST Type E, J, K, N	32.009 °F (0.005 °C) +0.00054% of reading	
	NIST Type R, S, T	32.027 °F (0.015 °C) of reading ≥ 392 °F (200 °C) 32.036 °F (0.02 °C) - 0.0032% of reading if not	

Performance Specification

Reference Accuracy	Refer Table 1	
Stability	RTDs	±0.125 of reading or 32.27 °F (0.15 °C), whichever is greater, for 24 months
	Thermocouples	±0.125 of reading or 32.27 °F (0.15 °C), whichever is greater, for 24 months
Repeatability	±0.05% of span	
Ambient Temperature Effect	Refer Table 2	
Power Supply Effect	Less than ±0.005% of span per Volt	
Update Time	0.5 secs	
Turn-On Time	5 secs	
Failure Mode	Fail High	Current ≥ 21.75 mA
	Fail Low	Current ≥ 3.75 mA
Ordering Temperature	-40 °F to 185 °F (-40 °C to 85 °C)	
LCD Meter Ordering Temperature	-22 °F to 176 °F (-30 °C to 80 °C)	
Humidity Limits	0% to 100% RH	

Functional Specifications

Range and Sensor Limits	Refer Table 1
Zero and Span Adjustment Limits	Zero and span values can be set anywhere within the range limits stated in Table 1.
	Span must be greater than or equal to the minimum span stated in Table 1
Output (Analog Current and Digital Data)	Two wire 4-20 mA, Digital Process, Digital Process valve superimposed on 4-20 mA signal, available to any host that conforms to the HART protocol.
Power Supply	12 to 45 VDC
Loop Load	<ul style="list-style-type: none"> • 0 to 1500 Ohm for Operation • 250 to 550 Ohm for HART Communications
Ambient Humidity Limits	0% to 100% Relative Humidity
Ambient Temperature Limits	<ul style="list-style-type: none"> • -40 °F to 185 °F (-40 °C to 85 °C) (without condensing for Tek-Temp 2100A) • -22 °F to 176 °F (-30 °C to 80 °C) (with LCD module)
Storage Temperature	-40 °F to 185 °F (-40 °C to 85 °C)

Physical Specifications

PHYSICAL SPECIFICATION			
Electrical Connections	½" to 14" NPT (w/M 3.5)	Weight (excluding option items)	2.64 lb (1.2 kg) (Standard) 5.73 lb (2.6 kg) (SST Housing)
Electronics Housing	Aluminum	2" Pipe Stanchion Type Bracket	Angle or Flat Type
O-rings	Buna-N	Housing Class	Waterproof (IP67)

Installation

The Tek-Temp 2100A Temperature Transmitter can be mounted in 2 ways:

- Remote Mounting Sensor
- Direct Mounting Sensor

It is possible to install temperature sensor on both sides of the transmitter.

- ⚠ Install per local installation codes. Qualified cable entry or stopping box required.
- ⚠ Threads must be assembled with loctite thread sealant and have a minimum of five full threads engagement and 0.02 ft axial length engagement.

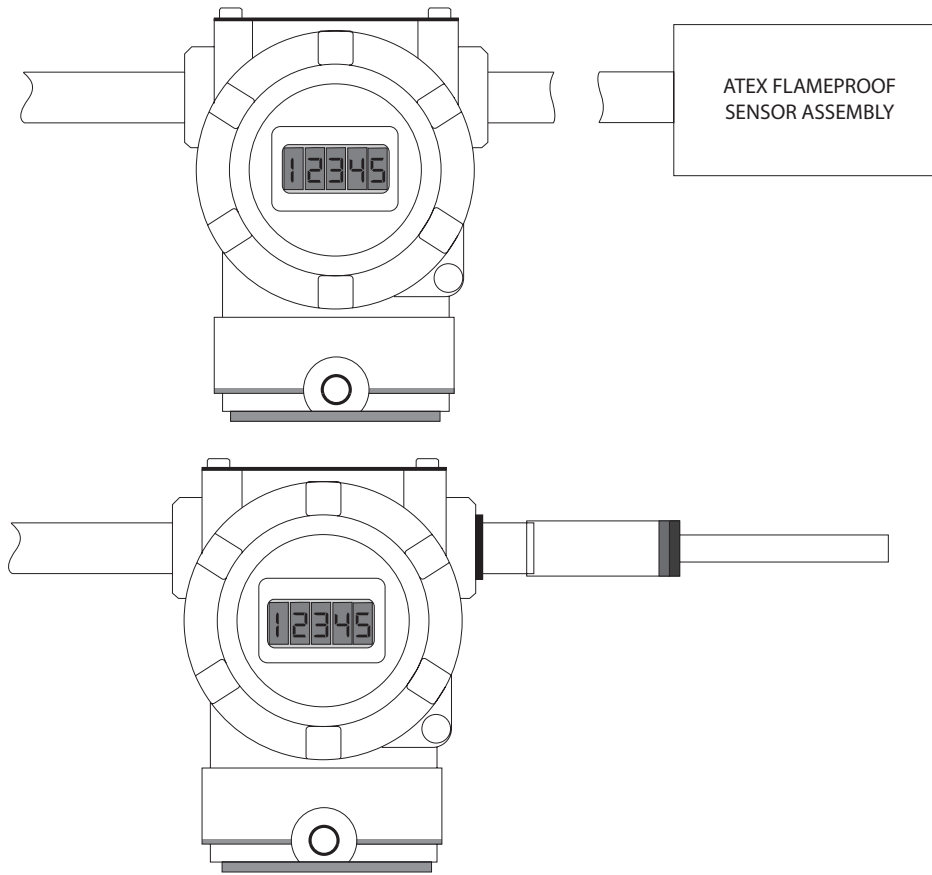

Model Chart

Example	Tek-Temp 2100A	S	1	FM	LCD	Tek-Temp 2100A-S-1-FM-LCD
Series	Tek-Temp 2100A					Explosion-proof Temperature Transmitter
Sensor Elements		S				Single Element
Housing and Electrical Connection			1			½" to 14" NPTF, Epoxy Coated Aluminum
Hazardous Location Certificates				FM		FM/FMc Explosion-proof (Class I/II/III, Div. 1, Group A-D/E-G)
Options					M0	Blind Unit
					LCD	LCD Display
					FC	Factory Calibration, No Certificate
					TAG	Stainless Steel Tag
					CC3	Custom Range, 3 point Cal Cert

Popular Models

Model Number	Description
2100A-S-1-FM-LCD	Explosion-proof Temperature Transmitter, Single Element, LCD

Customer Service & Support



TEKMATION LLC reserves the right to change the designs and/or materials of its products without notice. The contents of this publication are the property of TEKMATON and cannot be reproduced by any other party without written permission. All rights reserved. Copyright © 2016 TEKMATON LLC TEKMATON LLC DOC # TEK/ITPS/CAT/240520/2100A/01.2



www.tek-trol.com

Tek-Trol LLC

796 Tek Drive Crystal Lake,
IL 60014, USA



+1 847-857-6076



tektrol@tek-trol.com



www.tek-trol.com

Tek-Trol is a fully owned subsidiary of TEKMATON LLC. We offer our customers a comprehensive range of products and solutions for process, power and oil & gas industries. Tek-Trol provides process measurement and control products for Flow, Level, Temperature & Pressure measurement, Control valves & Analyzer systems. We are present in 15 locations globally and are known for our knowledge, innovative solutions, reliable products and global presence.