

Tek-Bar 3800XP

Multivariable Transmitter / Flow Computer



Quick Start Guide

1. Before you begin

This guide provides basic guidelines to assist you in quickly getting started.



Installation of the transmitter in an explosive environment must be in accordance with the appropriate local, national, and international standards, codes, and practices. Review the approvals section of the Tek-Bar3800XP Multivariable Transmitter / Flow Computer reference manual for any restrictions associated with a safe installation.



Do not remove the transmitter covers in explosive environments when the circuit is live.



Make sure the transmitter is installed by qualified personnel and in accordance with applicable codes of practice.

2. Unpack

Tek-Bar 3800XP (MVT) Multivariable Transmitter / Flow Computer

3. Dimensional Drawings

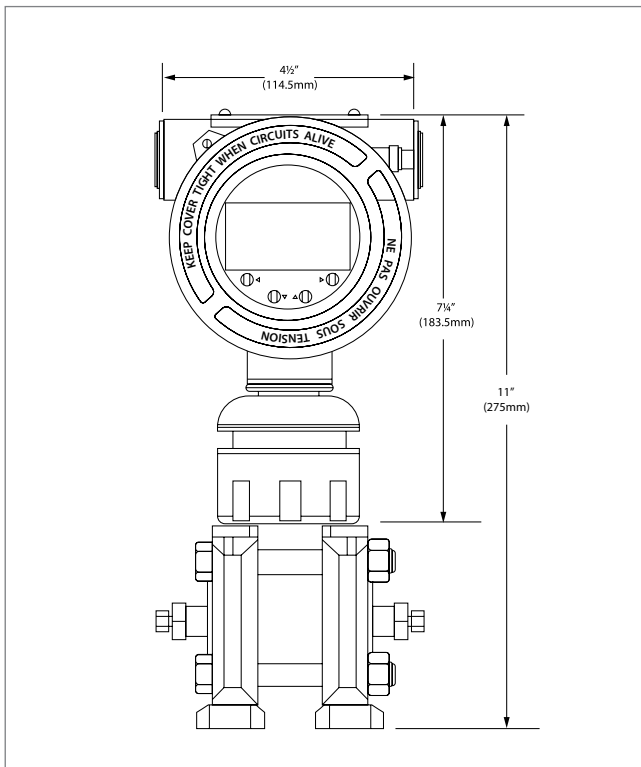

Fig 1: 3800XP MVT Front View

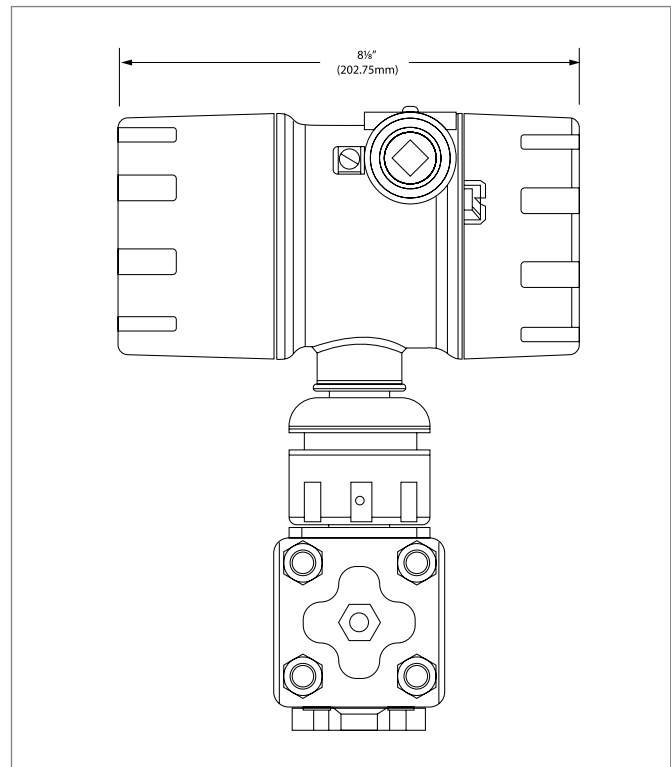

Fig 2: 3800XP MVT Side View

4. Power Supply

- Jumper Location

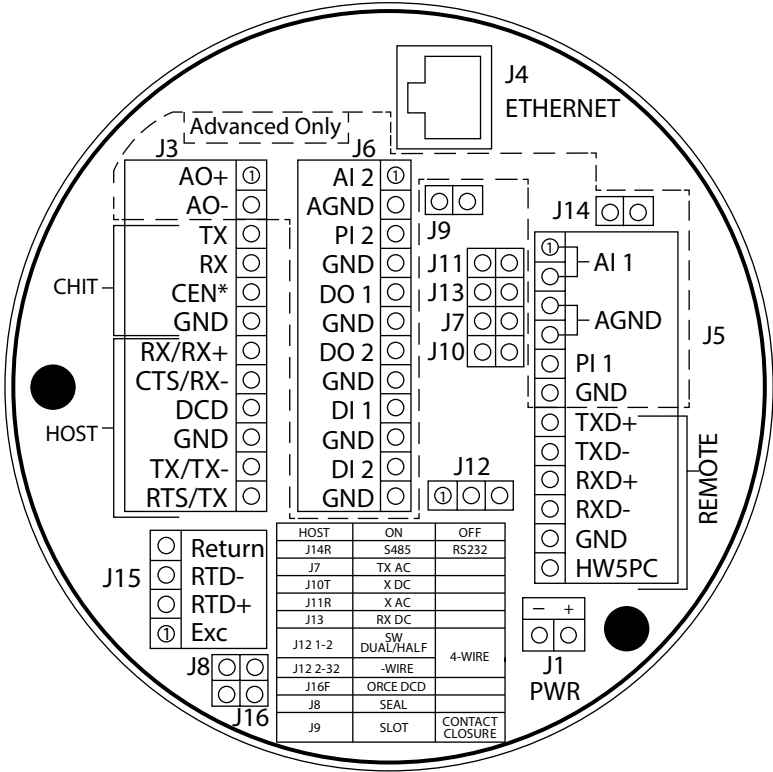

Fig 3: Terminal Board Jumper Location

Table 1: Terminal Board Jumper Locations

Host	ON	OFF
J14	RS485	RS232
J7	TX AC	
J10	TX DC	
J11	RX AC	
J13	RX DC	
J12 1-2	SW Dual/ Half	4-Wire
J12 2-3	2-Wire	
J16	Force DCD	
J8	Seal	
J9	SLOT	Contact Closure

Quick Start Guide

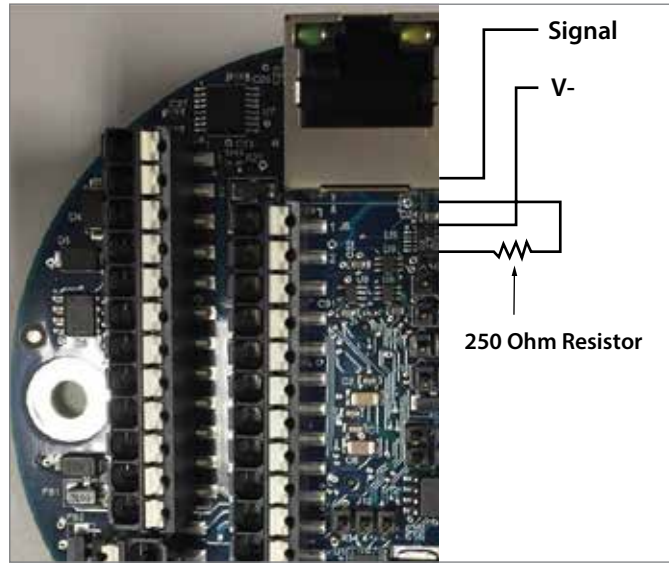

Fig 4: Low Power Transmitter and Local Analog Inputs (4-20 mA)

Table 2: Typical Switch Configurations

Board	Designator	Description	ON	OFF	Default
HMI	JP2	Bluetooth Development	Development	Auto-Run	OFF
HMI	JP3	Over the Air Bluetooth Update	OTA Mode	Disable	ON
CPU	JP1	Bootloader Protect	Protect	Write	ON
CPU	JP2	Bluetooth Disable	Disable	Enable	OFF
CPU	SW1	Battery Disconnect Switch	Battery Backup	Storage/Cold Start	OFF
Terminal	J7	Host TX AC Termination	Terminated	Unterminated	OFF
Terminal	J8	Sealing Jumper	Sealed	Open	OFF
Terminal	J9	Pulse Mode	Slot	Contact	OFF
Terminal	J10	Host TX DC Termination	Terminated	Unterminated	OFF
Terminal	J11	Host RX AC Termination	Terminated	Unterminated	OFF
Terminal	J12 1-2	Host Duplex Setting	Software Control	4-Wire	OFF
Terminal	J12 2-3		2- Wire		ON
Terminal	J13	Host RX DC Termination	Terminated	Unterminated	OFF
Terminal	J14	Host Mode	RS485	RS232	OFF
Terminal	J16	Force DCD	Forced On	From User	OFF
I/O	JP3	HART Processor Configuration	Not Used	Normal Operation	OFF

- Flow Run Requirements

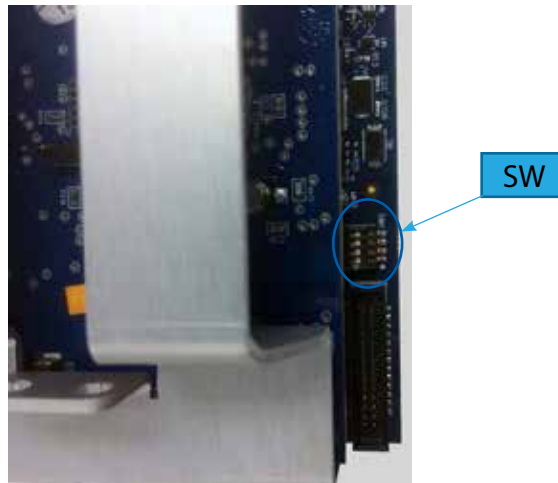

Fig 5: Main Board Switch Location (SW1)

Table 3: Main Board Switch SW1 Default Conditions

SW1	Description	Function	Default
1	Boot loader selection	CPU runs the boot loader upon power-up when the switch is on	OFF
2	Debugger selection	CPU runs the debugger upon power-up when the switch is on. Function not available	OFF
3	Continuous power on	System stays in wake-up mode when the switch is on	OFF
4	System reset	Momentarily switch on to reset the system	OFF

- Grounding

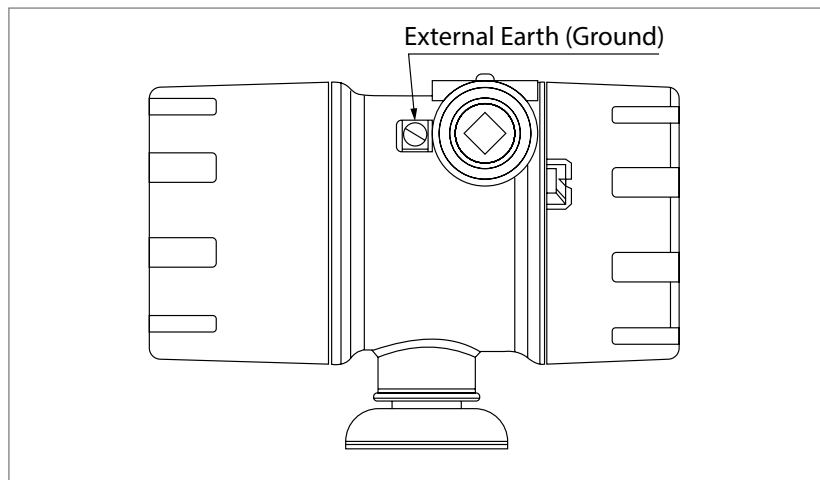

Fig 6: Grounding Connection

Quick Start Guide

- Bluetooth Operation



Fig 7: Bluetooth Operation JP2 and JP3

Table 4: Bluetooth Pin Description

OFF	Factory Default - Self Run Mode
ON	Bluetooth Disable (Must Power Cycle after Jumper set)
ON	OTA (Over the Air Mode) - Factory Default Mode
OFF	Manufacturing Use Only

- HART Communication

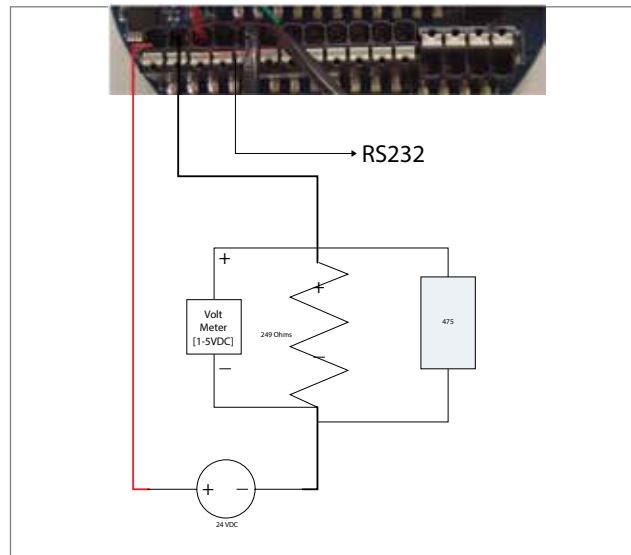

Fig 8: HART connection for the 4-20mA current loop

5. Installations

• Pole Mounting

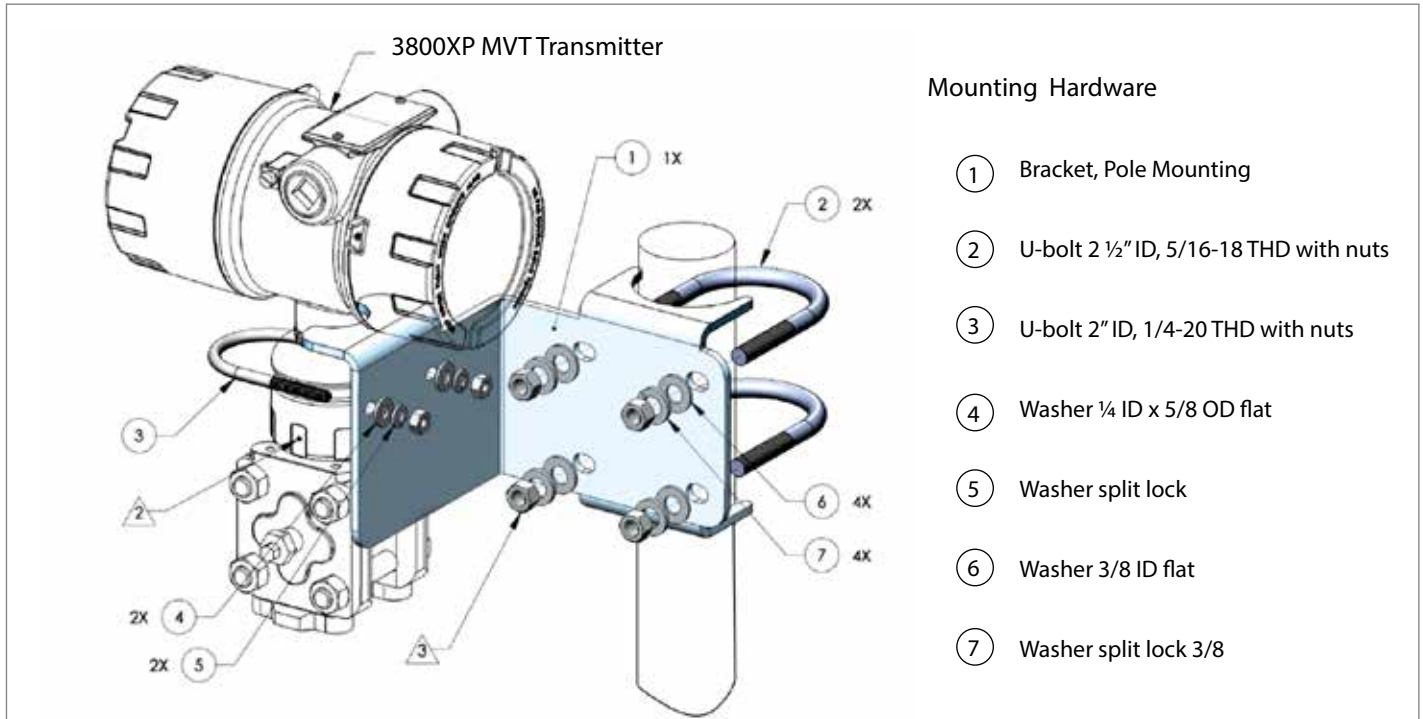

Fig 9: 3800XP MVT Pole Mounting

• Enclosure Cap Locking Screw

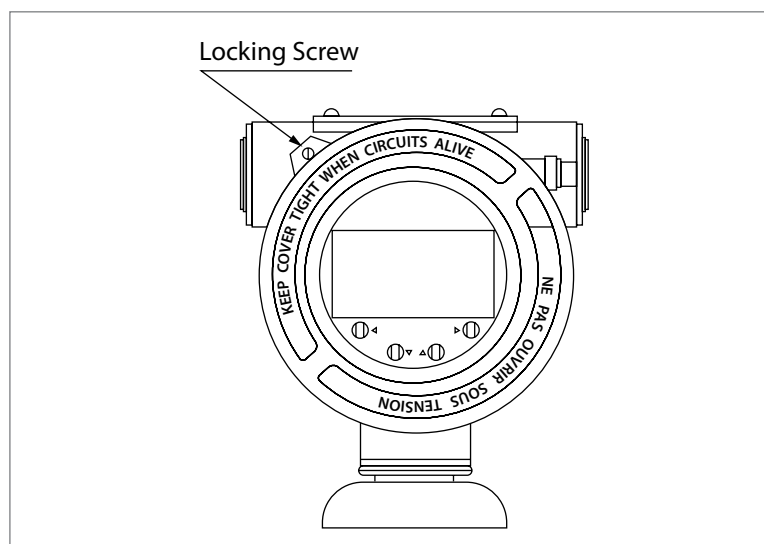

Fig 10: Enclosure Cap Locking Screw

Quick Start Guide

- Installation for Dry or Wet Gas Flows

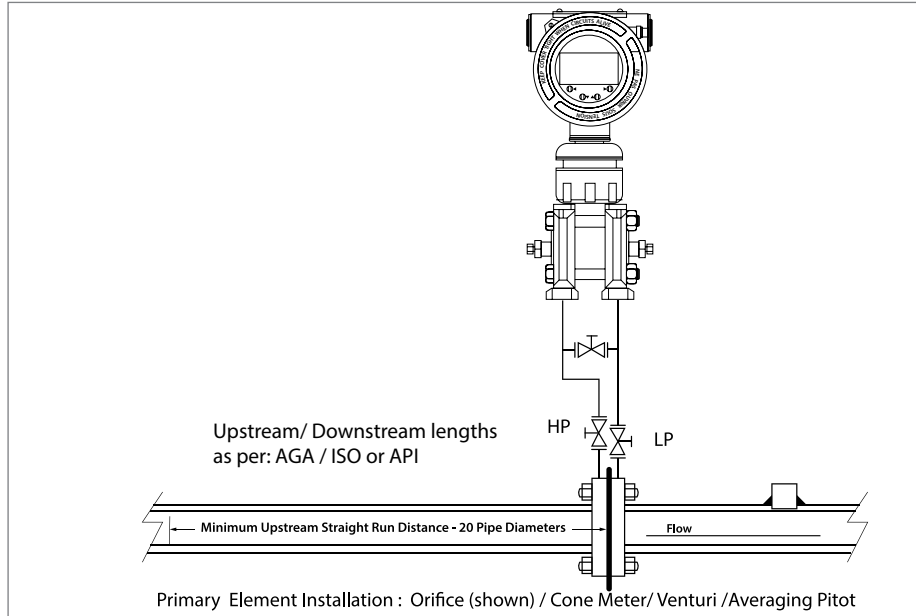
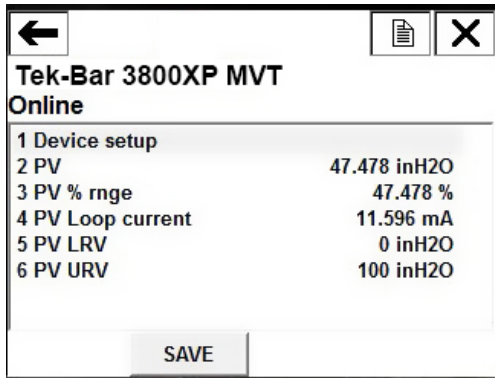

Fig 11: Dry or Wet Gas Flows Installation

6. Operations

- Inline Online Menu



- Device Set Up Menu

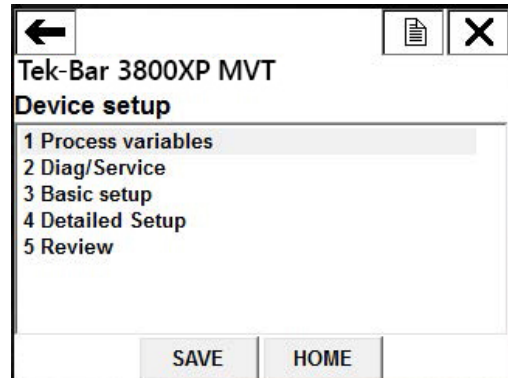

- Process Variable Menu

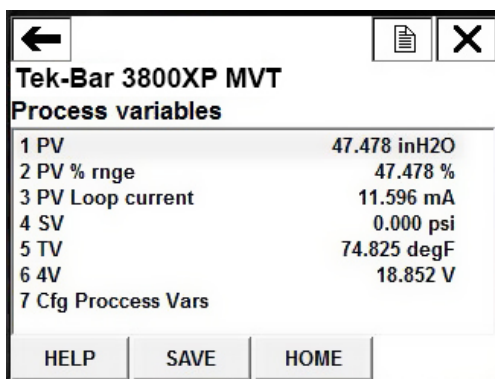

- Device Set Up Menu

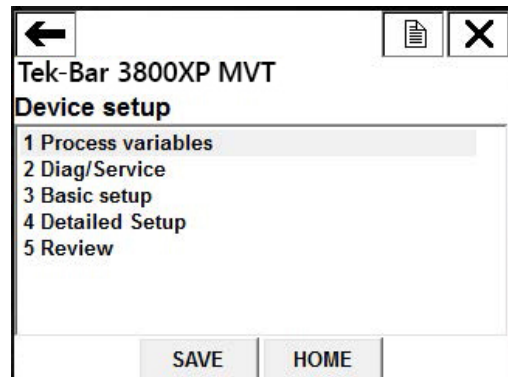

• **Diagnostics or Service Menu**

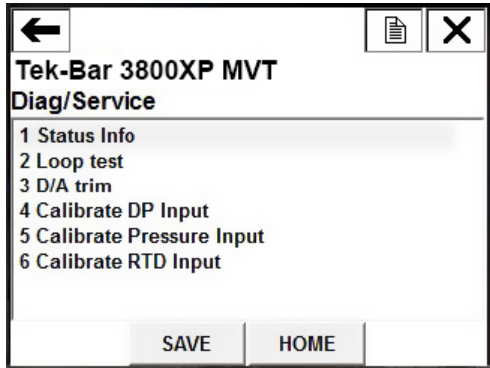

• **Status Info Menu**

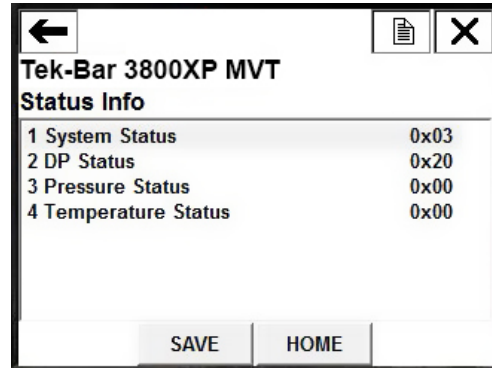

• **Basic Set UP Menu**

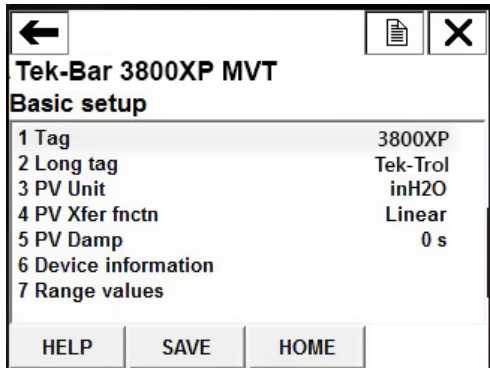

• **Device Information Menu**

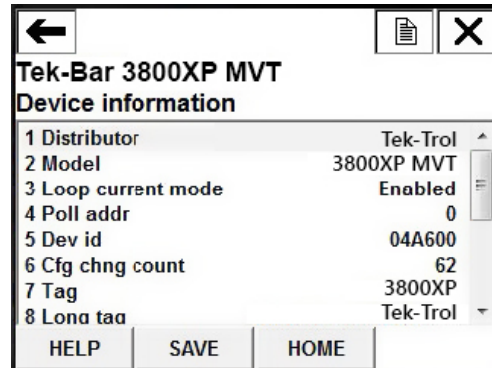

• **Range Value Menu**

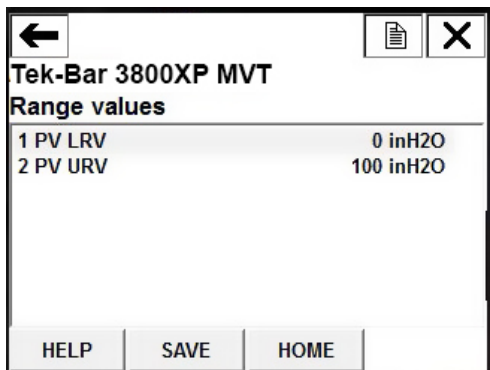

• **Detailed Set UP Menu**

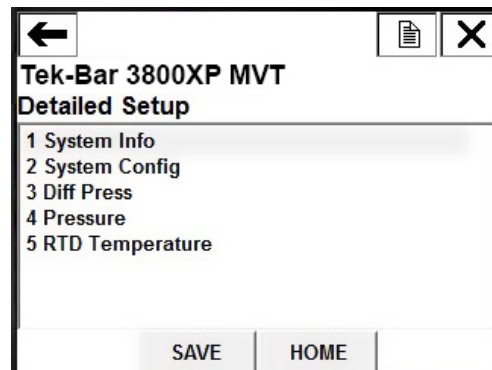

Quick Start Guide

7. Menu Tree

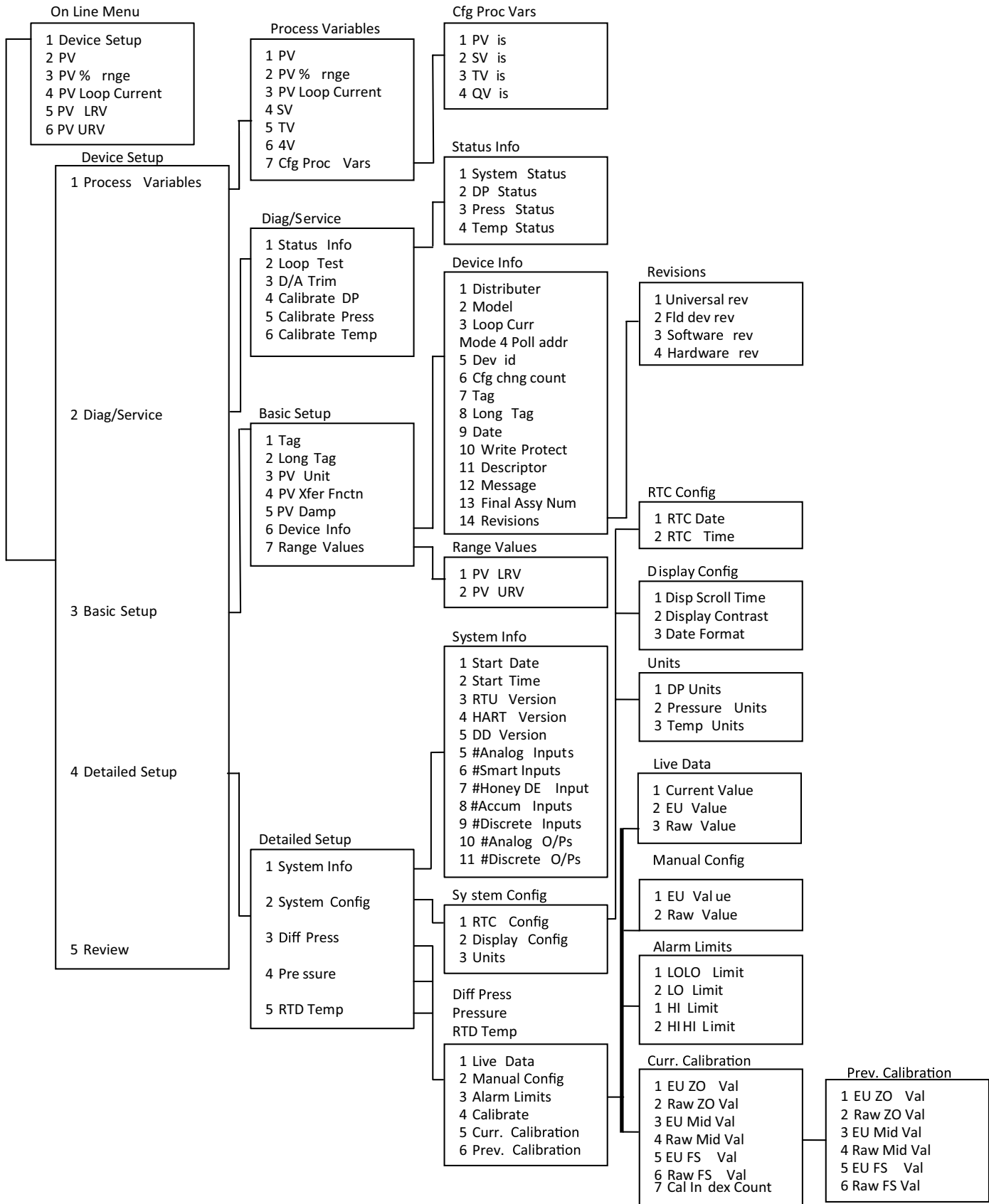

8. Troubleshooting

Symptom	Solution
Instrument is not working and/or LCD not displaying	<ul style="list-style-type: none">• Press wakeup button on the display• Check input voltage polarity• Check input voltage level to be 10 to 30volts• Replace Terminal board



Fig 12: Actual Tek-Bar 3800XP Multivariable Transmitter / Flow Computer



Technology Solutions

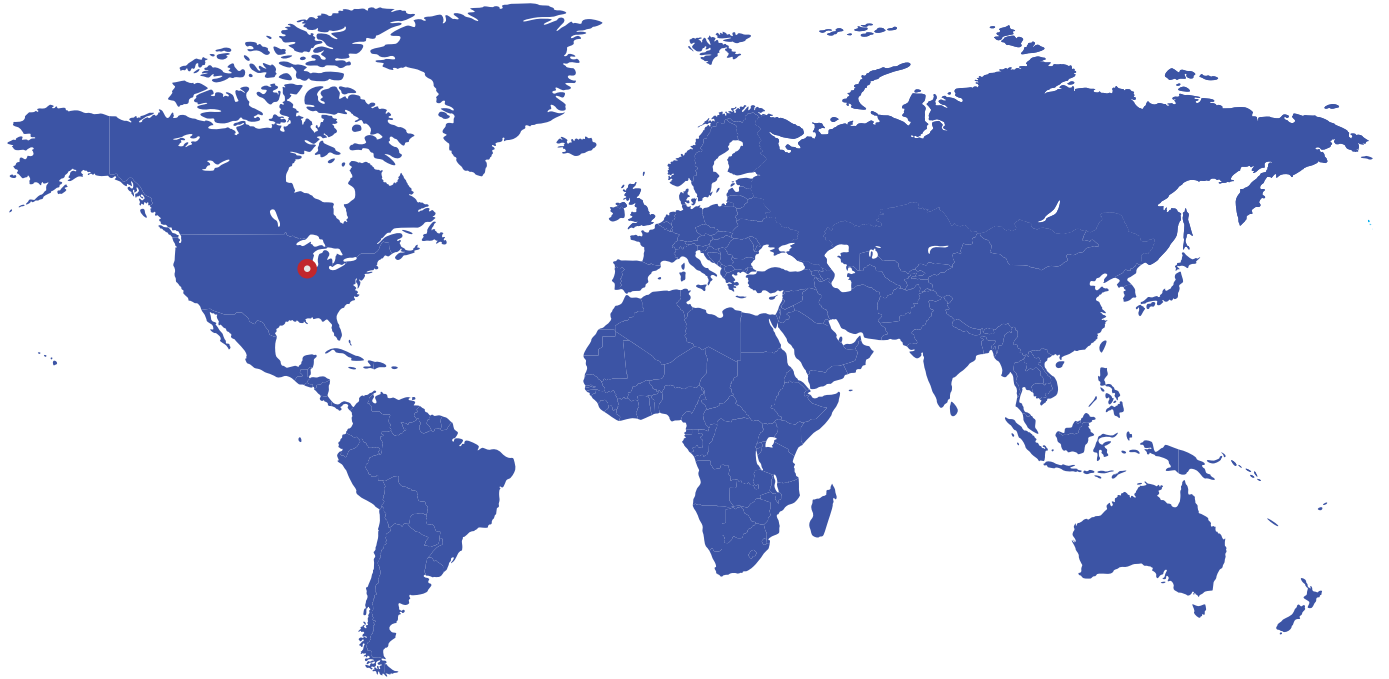

796 Tek Drive
Crystal Lake, IL 60014
USA

Fax: +1 847 655 6147

Email: tektrol@tek-trol.com

www.tek-trol.com

 +1 847-857-6076

 tektrol@tek-trol.com

 www.tek-trol.com

Tek-Bar 3800XP