



TEK-SUB 4800B

Submersible Level Transmitter

Instruction Manual

Document Number: IM-4800B



www.tek-trol.com

NOTICE

Read this manual before working with the product. For personal and system safety, and for optimum product performance, make sure you thoroughly understand the contents before installing, using, or maintaining this product.

For technical assistance, contact

Customer Support

796 Tek-Drive

Crystal Lake, IL 60014

USA

Tel: +1 847 857 6076, +1 847 655 7428

© **COPYRIGHT Tek-Trol LLC 2022**

No part of this publication may be copied or distributed, transmitted, transcribed, stored in a retrieval system, or translated into any human or computer language, in any form or by any means, electronic, mechanical, manual, or otherwise, or disclosed to third parties without the express written permission. The information contained in this manual is subject to change without notice.

Table of Contents

1	Safety Instructions	2
1.1	Intended Use	2
1.2	Safety Instructions from the Manufacturer	2
1.2.1	Disclaimer.....	2
1.2.2	Product Liability and Warranty	2
1.2.3	Information Concerning the Documentation.....	2
1.3	Safety Precautions	2
1.4	Packaging, Transportation and Storage	3
1.4.1	Packaging.....	3
1.4.2	Accessories.....	4
1.4.3	Transportation.....	4
1.4.4	Nameplate.....	4
2	Product Description	5
2.1	Introduction	5
2.2	Measuring Principle	5
2.3	Operation	6
2.4	Technical Specification	6
2.5	Dimensional Drawings	7
2.6	Model Chart	8
3	Installation	8
3.1	Considerations to be taken before Installation	9
3.2	Installation Methods	9
3.2.1	Installation in the Static Liquid	9
3.2.2	Installation in a Flowing liquid	10
4	Electrical Connections	10
4.1	Wiring Diagram	11
5	Operation	12
6	Maintenance	12
7	Troubleshooting	12

1 Safety Instructions

1.1 Intended Use

The Tek-Sub 4800B Submersible Level Transmitter is used to calculate the level of liquid in a tank by measuring the hydrostatic pressure in the tank.

1.2 Safety Instructions from the Manufacturer

1.2.1 Disclaimer

The manufacturer will not be held accountable for any damage that happens by using its product, including, but not limited to direct, indirect, or incidental and consequential damages.

Any product purchased from the manufacturer is warranted in accordance with the relevant product documentation and Terms and Conditions of Sale.

The manufacturer has the right to modify the content of this document, including the disclaimer, at any time for any reason without prior notice, and will not be answerable in any way for the possible consequence of such changes.

1.2.2 Product Liability and Warranty

The operator shall bear authority for the suitability of the device for the specific application. The manufacturer accepts no liability for the consequences of misuse by the operator. Wrong installation or operation of the devices(systems) will cause the warranty to be void. The respective Terms and Conditions of Sale, which forms the basis for the sales contract shall also apply.

1.2.3 Information Concerning the Documentation

To prevent any injury to the operator or damage to the device, it is essential to read the information in this document and the applicable national standard safety instructions. This operation manual contains all the information that is required in various stages, such as product identification, incoming acceptance and storage, mounting, connection, operation and commissioning, troubleshooting, maintenance, and disposal.

1.3 Safety Precautions

You must read these instructions carefully prior to installing and commissioning the device. These instructions are an important part of the product and must be kept for future reference. Only by observing these instructions, optimum protection of both personnel and the environment, as well as safe and fault-free operation of the device can be ensured.

For additional information that is not discussed in this manual, contact the manufacturer.

Warnings and Symbols Used

The following safety symbol marks are used in this operation manual and on the instrument.



WARNING

Indicates a potentially hazardous situation which, if not avoided, could result in serious injury or death.



CAUTION

Indicates a potentially hazardous situation which, if not avoided, may result in minor or moderate injury. It may also be used to alert against unsafe practices.



NOTE

Indicates that operating the hardware or software in this manner may damage it or lead to system failure.

1.4 Packaging, Transportation and Storage

1.4.1 Packaging

The original manufacturer's package consists of

1. Tek-Sub 4800B Submersible Level Transmitter



1.4.2 Accessories



Light Surge Protection box

1.4.3 Transportation

- Avoid impact shocks to the device and prevent it from getting wet during transportation.
- Verify local safety regulations, directives, and company procedures with respect to hoisting, rigging, and transportation of heavy equipment.
- Transport the product to the installation site using the original manufacturer's packing whenever possible.

1.4.4 Nameplate

The nameplate lists the order number and other important information, such as design details and technical data



NOTE

Check the device nameplate to ensure that the device is delivered according to your order. Check for the correct supply voltage printed on the nameplate.



2 Product Description

This section covers the reference and specification data, as well as the ordering information.

2.1 Introduction

The Tek-Sub 4800B Submersible Level Transmitter is a high-performance level transmitter specially designed for measuring the level of liquids and slurries. The transmitter has a highly accurate silicon piezoresistive pressure sensor as a sensing element. It is capable of continuously sensing and measuring liquid level with high precision.

Tek-Trol's Submersible Level Transmitters have several level ranges, output options, and custom cable lengths, ensuring a perfect fit for new or existing installations. They are frequently used with a SCADA, PLC, or compatible display/control system for liquid level indication or control.

2.2 Measuring Principle

The Tek-Sub 4800B Submersible Level Transmitter consists of a sensor attached to a long cable, which is lowered to the bottom of a tank or well. The sensor operates by measuring the hydrostatic pressure of the liquid. Hydrostatic pressure (or head pressure) is the pressure exerted by the liquid in the tank or well. The hydrostatic pressure measured by the sensor is determined by two parameters: the density and height of the liquid. With liquid density remaining constant, changes in hydrostatic pressure necessarily reflect a difference in liquid level.

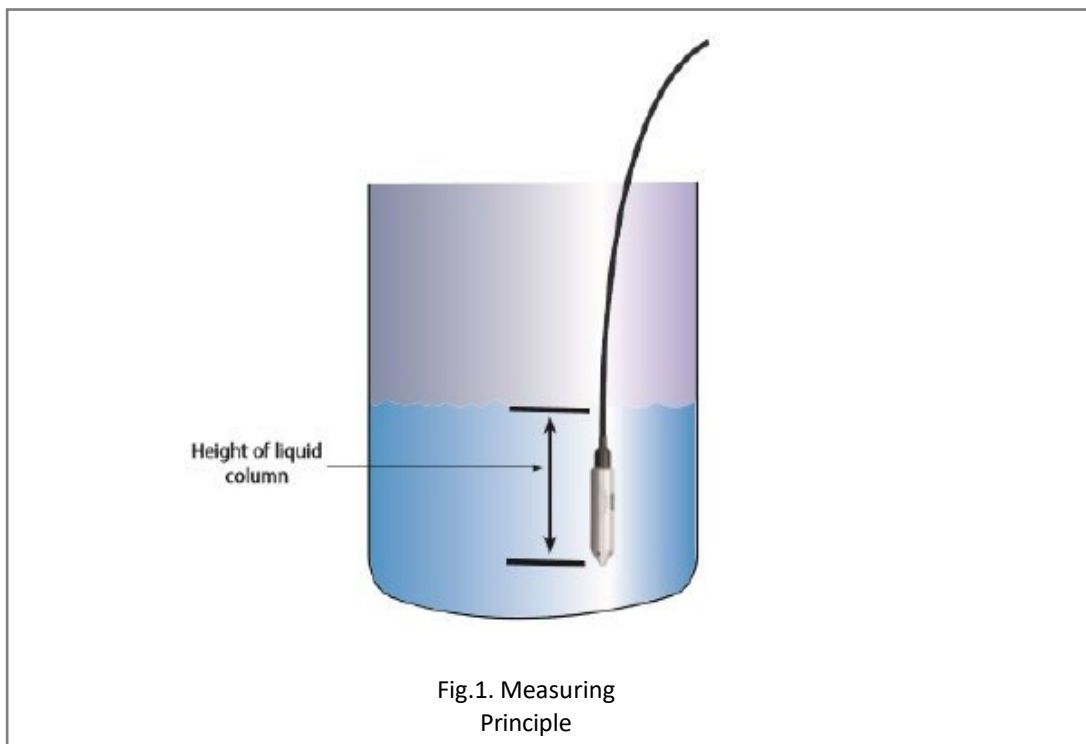

2.3 Operation

Typical Tek-Sub 4800B Submersible Level Transmitter application.

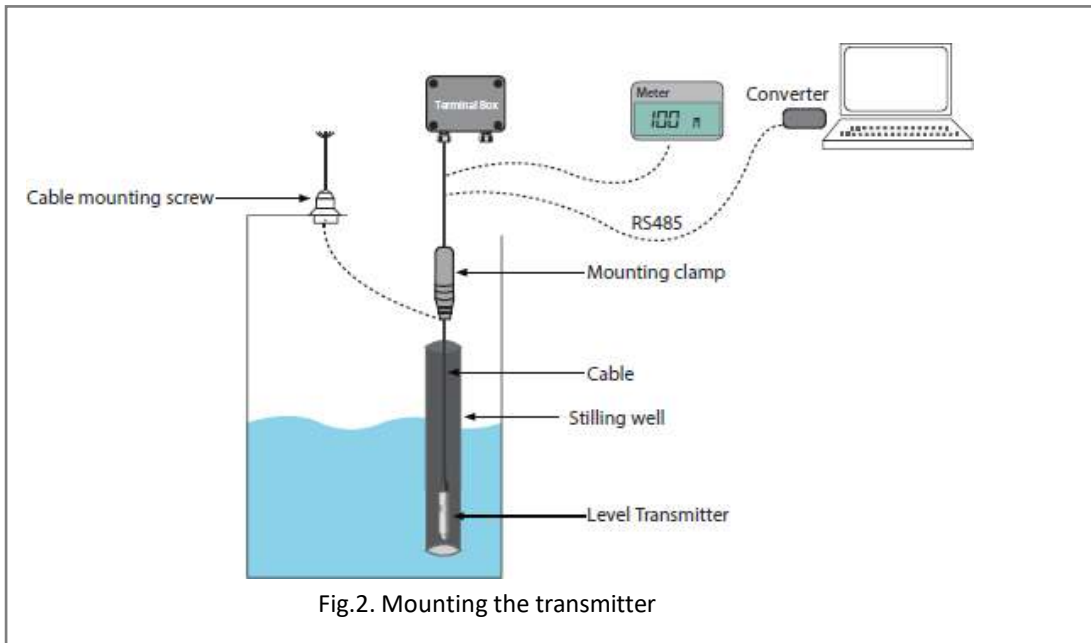

The pressure at the bottom of the tank is related to the height of the liquid. This pressure is called hydrostatic pressure or head pressure. Typical units for measurement of hydrostatic pressure are inches, feet, or meters of water column. In a water column, the hydrostatic pressure of 27.7" w.c. is approximately equivalent of 1 PSI. The volume of water or shape of the tank or vessel does not affect the hydrostatic head pressure as it is height of water that affects the pressure. Whether it is in a large water tank or a small bucket of water, the hydrostatic pressure of 27.7" w.c. is the same.

Modern PLC's and HMI's can calculate the liquid level of a tank by entering the geometry of the tank and the specific gravity of the liquid.

2.4 Technical Specification

Pressure range	5 psig to 20 psig (3.5 mH ₂ O to 14 mH ₂ O), Other ranges available
Pressure type	Gauge (Vented)
Over pressure	150% of Span
Accuracy	±0.5% FS
Temperature coefficient-zero	±0.75% FS (typ.), ±1.5% FS (max.) Over compensated temperature range
Temperature coefficient-span	±0.75% FS (typ.), ±1.5% FS (max.) Over compensated temperature range
Long term stability	±0.2% FS/year (typ.), ±0.3% FS/year (max.)
Output signal	4-20 mA, RS-485, 0.5-4.5 VDC

Power supply (Vs)	12 to 36 VDC
Load resistance (RL)	$R_L < (V_s - 12) / 0.02A$
Vibration	10g-force (20-2000 Hz)
Shock	100g-force (10 ms)
Cycles	10×10^6 cycles
Insulation resistance	100 M Ω /50 VDC
Compensated temperature range	32 °F to 140 °F (0 °C to 60 °C)
Storage temperature range	-40 °F to 257 °F (-40 °C to 125 °C)
Housing	304 SS
Cable	PTFE or Polyurethane
Diaphragm	316L SS
Protection	IP68
Seal ring	Viton
Oil filling	Silicone oil
Weight	0.9 lbs (408 g)

2.5 Dimensional Drawings

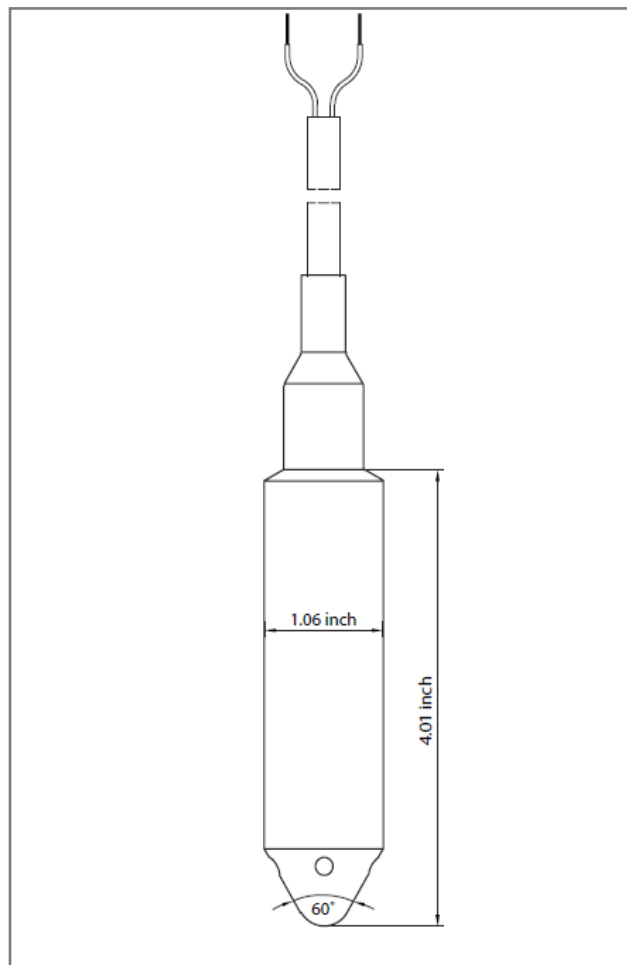

2.6 Model Chart

Example	Tek-Sub 4800B	05	42	05	T14	#	Tek-Sub 4800B-05-42-05-T14
Series	Tek-Sub 4800B						Submersible Level Transmitter
Range Options		05 10 15 20					5 psig (3.5 meters H ₂ O) 10 psig (7 meters H ₂ O) 15 psig (10.5 meters H ₂ O) 20 psig (14 meters H ₂ O)
Output			42 43 45 48 49				4-20mA 4-20mA, HART 0.5 - 4.5VDC Low-Voltage Modbus (5 VDC) Modbus RS-485
Accuracy				05			0.5% FS
Cable Length and Type					P14 P20 P34 T14 T20 T34		40 Feet of Polyurethane Cable 60 Feet of Polyurethane Cable 100 Feet of Polyurethane Cable 40 Feet of PTFE Cable 60 Feet of PTFE Cable 100 Feet of PTFE Cable
Option						LP	Lighting Surge Protection box

3 Installation

This section covers instructions on installation and commissioning. Installation of the device must be carried out by trained; qualified specialists authorized to perform such work.



CAUTION

- Installation must comply with local installation requirements and local electrical code.
- Do not switch on the power supply to the transmitter while installing it. It may cause injury to the operating personnel
- Prevent mud and sand from accumulating on the sensor probe. Otherwise, the transmitter would be damaged.

3.1 Considerations to be taken before Installation

Before installation make sure that:

- The static pressure produced by the liquid at the installation site does not exceed the transmitter's FS range.
- The measuring liquid is compatible with the transmitter's construction material.
- While mounting the transmitter, avoid areas subject to electrical noise, excessive vibrations, and radiant heat.

3.2 Installation Methods

Tek-Sub 4800B is suitable for both static as well as flowing liquid level measurement applications.

- Ensure that the measuring liquid is compatible with the transmitter's construction material.
- Insert the transmitter vertically down in the measurement container.
- Ensure that the transmitter is completely immersed in the liquid for maximum accuracy.
- Ensure the protection cap holes are not blocked due to suspended particles in the measuring liquid.

3.2.1 Installation in the Static Liquid

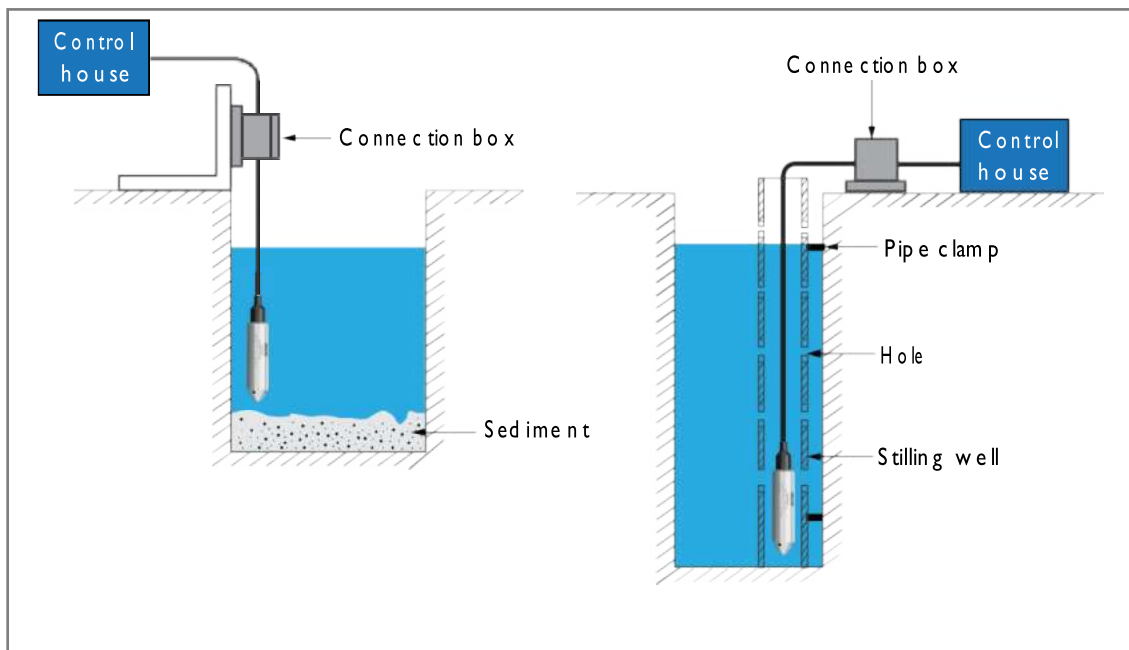

Fig.4. Installation in static liquid

Place the transmitter away from liquid resource to avoid effects of vibration and pressure influence. A stilling well is recommended for the best results.

3.2.2 Installation in a Flowing liquid

Fig 5 shows the installation method used in case of flowing liquid. For example, reservoir area, river channel.

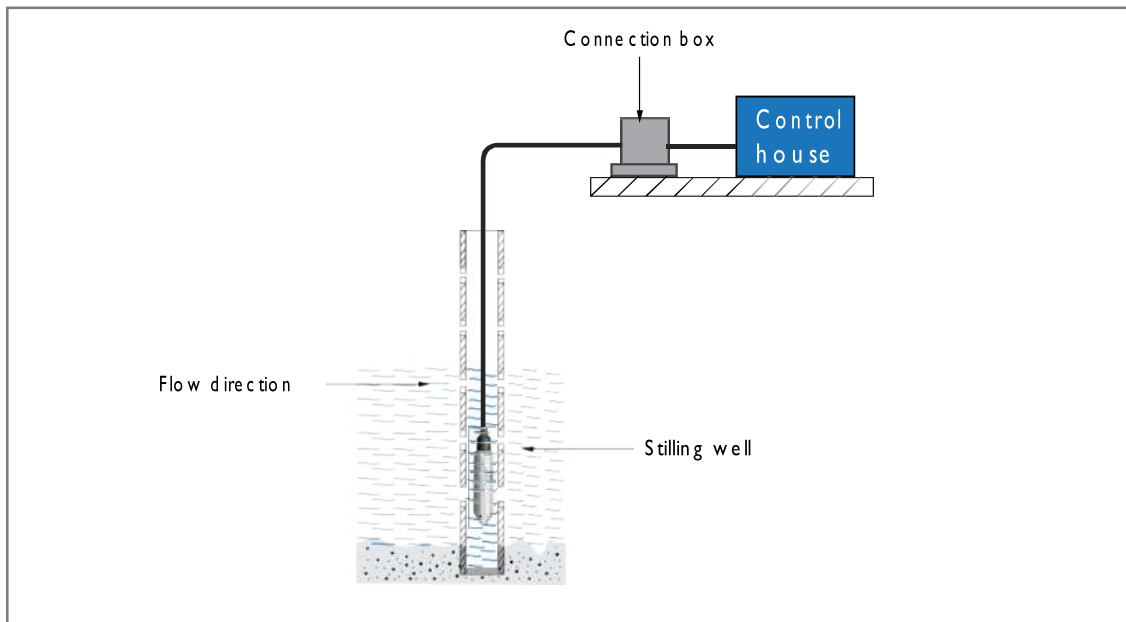

Fig.5. Installation in flowing liquid

A stilling well is recommended when there is a flowing liquid. A stilling well will dampen disruptions and provide a steady level for an accurate measurement.

4 Electrical Connections

This section provides general information on the electrical connections of the Tek-Sub 4800B Submersible Level Transmitter.

An external power supply delivering 12-36 VDC with minimum current capability of 40 mA DC (per transmitter) is required to power the control loop.

Fig.6 illustrates the connection of the power supply, transmitter, and receiver.

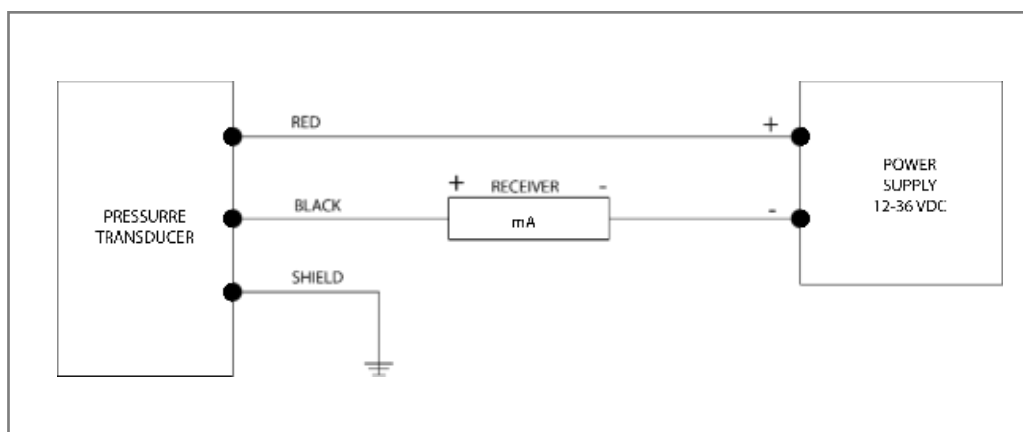

Fig.6. Power supply connections

The maximum receiver load resistance (RLmax) for the DC power supply voltage (Vs) is expressed as:

$$RL_{max} = V_s - 12V / 0.02A$$

Use of a shielded cable is recommended for control loop wiring.

Ensure proper ground connection. Improper grounding may lead to damage or poor signal integrity

4.1 Wiring Diagram

4~20mA/4~20mA+HART (2 wire)

Power+: Red

Signal+: Green

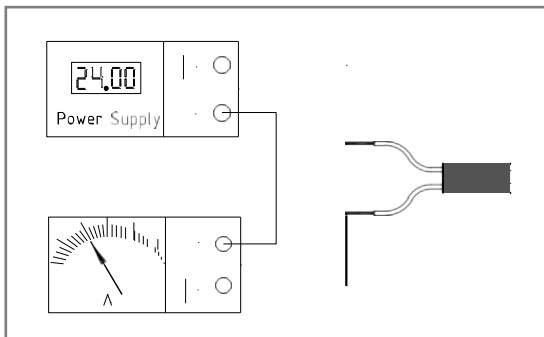

0~5voc/1~5voc/o.5~4.5V/0~10VDC(3 wire)

Power+: Red

Gnd: Green

Signal+: Yellow

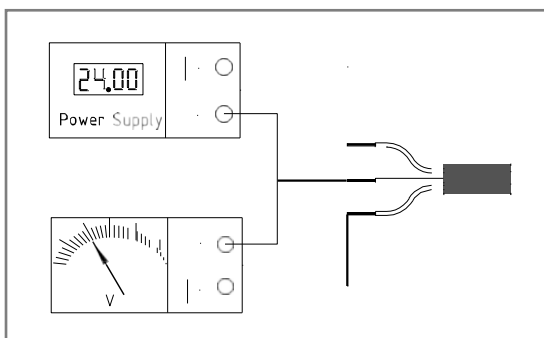

RS485 (4 wire)

Power+: Red

Gnd: Green

485 A: Yellow

485 B: Blue

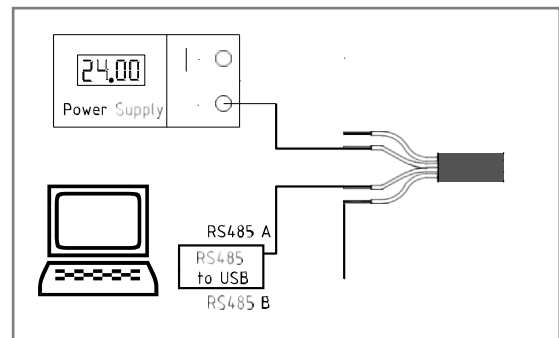

5 Operation

This section covers operation techniques and guidelines.

- Tek-Sub 4800B can be operated without any adjustment.
- Make sure that the installation and electrical connections are done properly before operation.
- Connect the excitation and operate.
- Wait for at least 30 minutes after connecting the excitation for reliable output signal.

6 Maintenance

This section covers maintenance techniques and guidelines.

The Tek-Sub 4800B Submersible Level Transmitter does not require to be maintained regularly, however the following points must be observed for better operation and reliability.

- Make sure that the wire connection is reliable.
- Make sure that the cable is not damaged.
- Clean the protection cap and diaphragm space regularly.
- Do not pull the cables violently or poke the diaphragm with metal objects.

7 Troubleshooting

This section provides troubleshooting techniques for most common operating problems.

Symptom	Corrective Action
No Output or Low Output	Check the polarity of the terminals. Check for intermittent shorts, open circuits and multiple grounds.
	Check that the adequate voltage is supplied to the transmitter. The transmitter requires 12 to 36 VDC.
	Verify sensor positioning and consider sensor cleaning.
High Output	Check for dirty or defective terminals and interconnecting pins.
	Check that the adequate voltage is supplied to the transmitter. The transmitter requires 12 to 36 VDC.
	Check the sensor limits to ensure that input to the sensor is within the range.
Erratic Output	Check that the adequate voltage is supplied to the transmitter. The transmitter requires 12 to 36 VDC.
	Check the polarity of the terminals. Check for intermittent shorts, open circuits and multiple grounds.
	Verify sensor positioning and consider sensor cleaning.

If error persists, contact Tek-Trol representative immediately.



TEKMATION LLC reserves the right to change the designs and/or materials of its products without notice. The contents of this publication are the property of TEKMATION and cannot be reproduced by any other party without written permission. All rights reserved. Copyright © 2009, TEKMATION, LLC
DOC:TEKTROL/3/MAN/240320/48008/00.13



www.tek-trol.com

Tek-Trol LLC

796 Tek Drive Crystal Lake,
IL 60014, USA



+1 847-857-6076



tektrol@tek-trol.com



www.tek-trol.com

Tek-Trol is a fully owned subsidiary of TEKMATION LLC. We offer our customers a comprehensive range of products and solutions for process, power and oil & gas industries. Tek-Trol provides process measurement and control products for Flow, Level, Temperature & Pressure Measurement, Control Valves & Analyzer systems. We are present in 15 locations globally and are known for our knowledge, innovative solutions, reliable products and global presence.

Flow | Level | Temperature | Pressure | Valves | Analyzers | Accessories | TekValSys