



# ***TEK-SUB 4800D***

## ***Wastewater Submersible Level Transmitter***

---

### **Instruction Manual**

Document Number: IM-4800D



[www.tek-trol.com](http://www.tek-trol.com)

---

**NOTICE**

Read this manual before working with the product. For personal and system safety, and for optimum product performance, make sure you thoroughly understand the contents before installing, using, or maintaining this product.

For technical assistance, contact

Customer Support

796 Tek-Drive

Crystal Lake, IL 60014

USA

Tel: +1 847 857 6076, +1 847 655 7428

© **COPYRIGHT Tek-Trol LLC 2022**

No part of this publication may be copied or distributed, transmitted, transcribed, stored in a retrieval system, or translated into any human or computer language, in any form or by any means, electronic, mechanical, manual, or otherwise, or disclosed to third parties without the express written permission. The information contained in this manual is subject to change without notice.

## Table of Contents

|          |  |           |
|----------|--|-----------|
| <b>1</b> | <b>Safety Instructions</b> .....                     | <b>2</b>  |
| 1.1      | Intended Use .....                                   | 2         |
| 1.2      | Safety Instructions from the Manufacturer .....      | 2         |
| 1.2.1    | Disclaimer .....                                     | 2         |
| 1.2.2    | Product Liability and Warranty .....                 | 2         |
| 1.2.3    | Information Concerning the Documentation .....       | 2         |
| 1.3      | Safety Precautions .....                             | 2         |
| 1.4      | Packaging, Transportation and Storage .....          | 4         |
| 1.4.1    | Packaging .....                                      | 4         |
| 1.4.2    | Accessories .....                                    | 4         |
| 1.4.3    | Transportation .....                                 | 4         |
| 1.4.4    | Nameplate .....                                      | 4         |
| <b>2</b> | <b>Product Description</b> .....                     | <b>5</b>  |
| 2.1      | Introduction .....                                   | 5         |
| 2.2      | Measuring Principle .....                            | 5         |
| 2.3      | Operation .....                                      | 6         |
| 2.4      | Technical Specification .....                        | 7         |
| 2.5      | Dimensional Drawings .....                           | 8         |
| 2.6      | Model Chart .....                                    | 8         |
| <b>3</b> | <b>Installation</b> .....                            | <b>9</b>  |
| 3.1      | Considerations to be taken before Installation ..... | 9         |
| 3.2      | Installation Methods .....                           | 9         |
| 3.2.1    | Installation in the Static Liquid .....              | 10        |
| 3.2.2    | Installation in a Flowing Liquid .....               | 10        |
| <b>4</b> | <b>Electrical Connections</b> .....                  | <b>11</b> |
| 4.1      | Wiring Diagram .....                                 | 12        |
| <b>5</b> | <b>Operation</b> .....                               | <b>12</b> |
| <b>6</b> | <b>Maintenance</b> .....                             | <b>13</b> |
| <b>7</b> | <b>Troubleshooting</b> .....                         | <b>13</b> |

## 1 Safety Instructions

### 1.1 Intended Use

The Tek-Sub 4800D Wastewater Submersible Level Transmitter is used to calculate the level of liquid in slurry and wastewater applications

### 1.2 Safety Instructions from the Manufacturer

#### 1.2.1 Disclaimer

The manufacturer will not be held accountable for any damage that happens by using its product, including, but not limited to direct, indirect, or incidental and consequential damages.

Any product purchased from the manufacturer is warranted in accordance with the relevant product documentation and Terms and Conditions of Sale.

The manufacturer has the right to modify the content of this document, including the disclaimer, at any time for any reason without prior notice, and will not be answerable in any way for the possible consequence of such changes.

#### 1.2.2 Product Liability and Warranty

The operator shall bear authority for the suitability of the device for the specific application. The manufacturer accepts no liability for the consequences of misuse by the operator. Wrong installation or operation of the devices (systems) will cause the warranty to be void. The respective Terms and Conditions of Sale, which forms the basis for the sales contract shall also apply.

#### 1.2.3 Information Concerning the Documentation

To prevent any injury to the operator or damage to the device, it is essential to read the information in this document and the applicable national standard safety instructions. This operation manual contains all the information that is required in various stages, such as product identification, incoming acceptance and storage, mounting, connection, operation and commissioning, troubleshooting, maintenance, and disposal.

### 1.3 Safety Precautions

You must read these instructions carefully prior to installing and commissioning the device. These instructions are an important part of the product and must be kept for future reference. Only by observing these instructions, optimum protection of both personnel and the environment, as well as safe and fault-free operation of the device can be ensured.

For additional information that is not discussed in this manual, contact the manufacturer.

### Warnings and Symbols Used

The following safety symbol marks are used in this operation manual and on the instrument.



#### **WARNING**

---

Indicates a potentially hazardous situation which, if not avoided, could result in serious injury or death.

---



#### **CAUTION**

---

Indicates a potentially hazardous situation which, if not avoided, may result in minor or moderate injury. It may also be used to alert against unsafe practices.

---



#### **NOTE**

---

Indicates that operating the hardware or software in this manner may damage it or lead to system failure.

---

## 1.4 Packaging, Transportation and Storage

### 1.4.1 Packaging

The original manufacturer's package consists of

1. Tek-Sub 4800D Wastewater Submersible Level Transmitter
2. Documentation



### 1.4.2 Accessories



Lighting Surge Protection box

### 1.4.3 Transportation

- Avoid impact shocks to the device and prevent it from getting wet during transportation.
- Verify local safety regulations, directives, and company procedures with respect to hoisting, rigging, and transportation of heavy equipment.
- Transport the product to the installation site using the original manufacturer's packing whenever possible.

### 1.4.4 Nameplate

The nameplate lists the order number and other important information, such as design details and technical data.



**NOTE**

Check the device nameplate to ensure that the device is delivered according to your order. Check for the correct supply voltage printed on the nameplate.



## 2 Product Description

This section covers the reference and specification data, as well as the ordering information.

### 2.1 Introduction

The Tek-Sub 4800D Wastewater Submersible Level Transmitter is exclusively designed for slurry and wastewater applications. Manufactured for precise level measurement, its clog-free silicon piezoresistive sensor determines liquid level without being affected by debris. Packaged in stainless steel housing, the waterproof cable makes it ideal for long-term trouble-free service. The 4800D is capable of real-time level measurement with several standard output signal options. The instantaneous level output is used for pump control to maintain the level or to report the real-time level status.

This high-performance level measurement device is available with several level ranges, custom cable lengths and materials, ensuring an ideal match for the application requirement.

### 2.2 Measuring Principle

The Tek-Sub 4800D Wastewater Submersible Level Transmitter has a sensor attached to a long cable, which is lowered to the bottom of the tank or well. The sensor operates by measuring the hydrostatic pressure of the liquid medium. Hydrostatic pressure (or head pressure) is the pressure exerted by the fluid in the tank or well. The level of hydrostatic pressure as measured by the sensor is determined by two parameters: the density and the height of liquid. With liquid density remaining constant, change in hydrostatic pressure necessarily reflects a difference in liquid level.

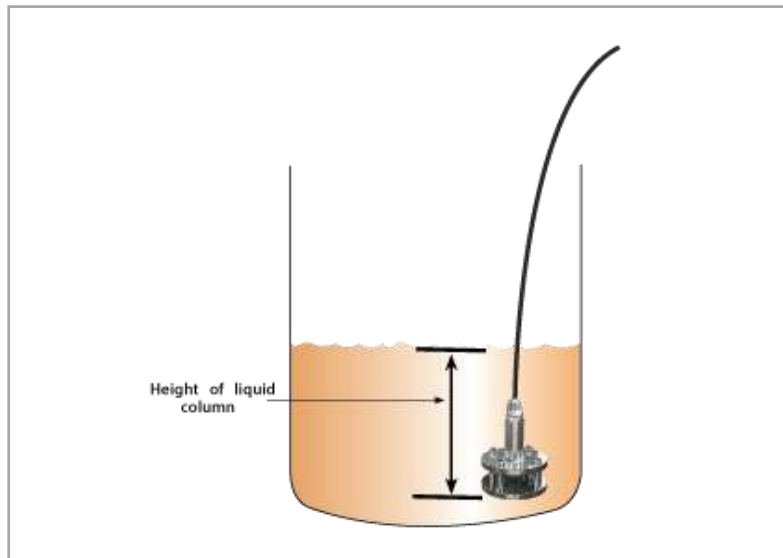

Fig.1. Measuring Principle

### 2.3 Operation

A typical Tek-Sub 4800D Wastewater Submersible Level Transmitter application is shown in the following figure.

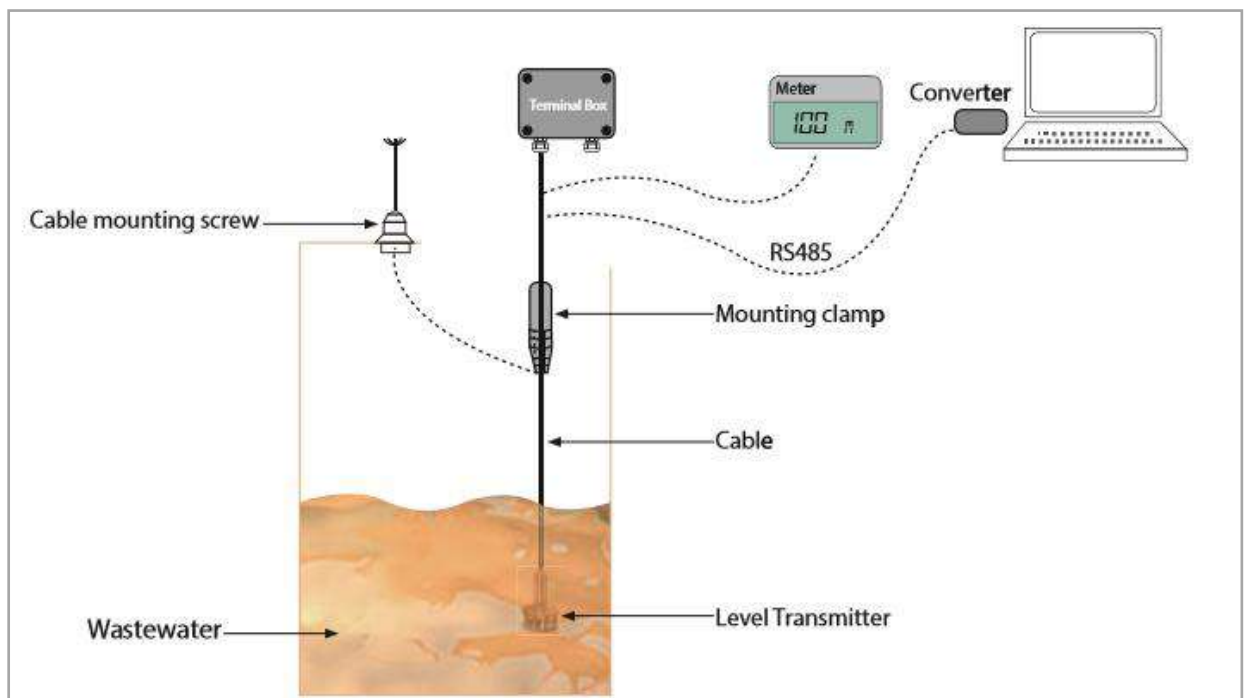

Fig.2. Mounting the transmitter

The pressure at the bottom of the tank or well is related to the height of the liquid. This level pressure is called hydrostatic pressure or head pressure. Typical units of measure for hydrostatic pressure are inches, feet, or meters of water column. In a



water column, a hydrostatic pressure of 27.7" w.c. is approximately equivalent to 1 PSI. The volume of water or the shape of the tank or vessel will not affect the hydrostatic pressure; it is the height of water that affects the pressure. Whether it is in a large water tank or a small bucket of water, the hydrostatic pressure 27.7" w.c. is the same.

Modern PLC's and HMI's can calculate the liquid level of a tank by entering the geometry of the tank and the specific gravity of the liquid.

## 2.4 Technical Specification

|                                   |  |
|-----------------------------------|--|
| Pressure range                    | 5 psig to 20 psig (3.5 mH <sub>2</sub> O to 14 mH <sub>2</sub> O), Optional ranges available |
| Pressure type                     | Gauge (vented)   |
| Over pressure                     | 150% of Spam   |
| Accuracy                          | 0.5% FS  |
| Temperature coefficient-zero      | ±0.75% FS (typ), ±1.5% FS (max) overcompensated temperature range                            |
| Temperature coefficient-span      | ±0.75% FS (typ), ±1.5% FS (max) overcompensated temperature range                            |
| Long term stability               | ±0.2% FS/year (typ.), ±0.3% FS/year (max.)   |
| Output signal                     | 4-20 mA, RS-485, 0.5-4.5 VDC   |
| Power supply (Vs)                 | 12 to 36 VDC   |
| Load resistance (R <sub>L</sub> ) | $R_L < (V_s - 12) / 0.02A$   |
| Vibration                         | 10g-force (20-2000 Hz)   |
| Shock                             | 100g-force (10 ms)   |
| Cycles                            | 10x10 <sup>6</sup> cycles  |
| Insulation resistance             | 100 MΩ/50 VDC  |
| Compensated temperature range     | 32 °F to 140 °F (0 °C to 60 °C)  |
| Operating temperature range       | -4 °F to 158 °F (-20 °C to 70 °C)  |
| Storage temperature range         | -40 °F to 257 °F (-40 °C to 125 °C)  |
| Media compatibility               | All media compatible with 316 SS   |
| Housing                           | 304 SS   |
| Cable                             | PTFE or Polyurethane   |
| Diaphragm                         | 316 SS, option ceramic   |
| Oil filling                       | Silicone oil   |
| Net weight                        | 8.8 lb (4000 g)  |

2.5 Dimensional Drawings

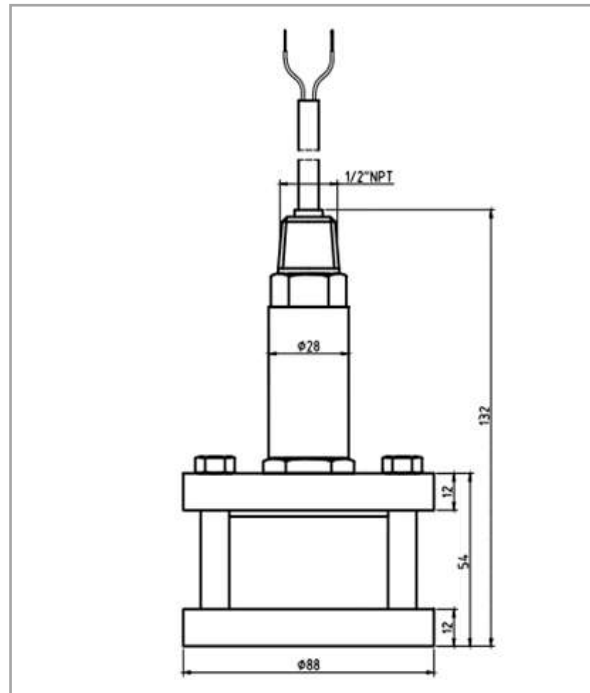

2.6 Model Chart

|                              |               |                      |                            |    |  |    |  |
|------------------------------|---------------|----------------------|----------------------------|----|--|----|--|
| <b>Example</b>               | Tek-Sub 4800D | 05                   | 42                         | 05 | P14                                    | #  | <b>Tek-Sub 4800D-05-42-05-P14</b>  |
| <b>Series</b>                | Tek-Sub 4800D |                      |                            |    |  |    | Wastewater Submersible Level Transmitter   |
| <b>Range</b>                 |               | 05<br>10<br>15<br>20 |                            |    |  |    | 5 psig (3.5 meters H <sub>2</sub> O)<br>10 psig ( 7 meters H <sub>2</sub> O)<br>15 psig (10.5 meters H <sub>2</sub> O)<br>20 psig (14 meters H <sub>2</sub> O)               |
| <b>Output</b>                |               |                      | 42<br>43<br>45<br>48<br>49 |    |  |    | 4-20 mA<br>4-20 mA<br>0.5-4.5 VDC<br>Low-Voltage Modbus (5 VDC)<br>Modbus RS-485   |
| <b>Accuracy</b>              |               |                      |                            | 05 |  |    | 0.5% FS  |
| <b>Cable Length and Type</b> |               |                      |                            |    | P14<br>P20<br>P34<br>T14<br>T20<br>T34 |    | 40 Feet of Polyurethane Cable<br>60 Feet of Polyurethane Cable<br>100 Feet of Polyurethane Cable<br>40 Feet of PTFE Cable<br>60 Feet of PTFE Cable<br>100 Feet of PTFE Cable |
| <b>Option</b>                |               |                      |                            |    |  | LP | Lighting Surge Protection box  |

### 3 Installation

This section covers instructions on installation and commissioning. Installation of the device must be carried out by trained, qualified specialists authorized to perform such work.



#### CAUTION

---

- Installation must comply with local installation requirements and local electrical code.
  - Do not switch on the power supply to the transmitter while installing it. It may cause injury to the operating personnel
  - Prevent mud and sand from accumulating on the sensor probe. Otherwise, the transmitter would be damaged.
- 

#### 3.1 Considerations to be taken before Installation

Before installation make sure that:

- The static pressure produced by the liquid at the installation site does not exceed the transmitter's FS range.
- The measuring liquid is compatible with the transmitter's construction material.
- While mounting the transmitter, avoid areas subject to electrical noise, excessive vibrations and radiant heat.

#### 3.2 Installation Methods

The Tek-Sub 4800D Wastewater Submersible Level Transmitter is suitable for static, as well as flowing liquid level measurement applications. The transmitter is factory calibrated and ready for operation without adjustment

- Ensure that the measuring liquid is compatible with the transmitter's construction material
- Insert the transmitter vertically down in the measurement container
- Ensure that the transmitter is completely immersed in the liquid for maximum accuracy
- Ensure the protection cap holes are not blocked due to suspended particles in the measuring liquid

3.2.1 Installation in the Static Liquid

Fig.4 shows the installation method used in case of static liquid.

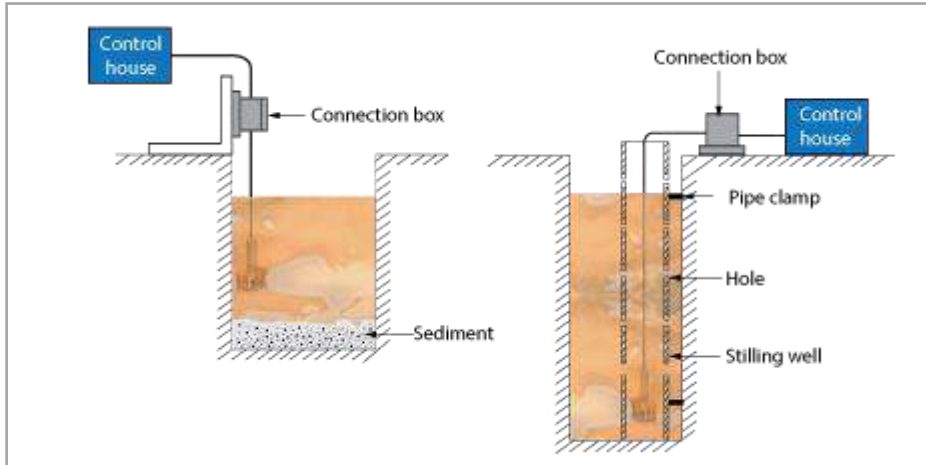

Fig.4. Installation in static liquid

- Place the transmitter away from liquid resource to avoid effects of vibration and pressure influence. A stilling well is recommended for the best results.
- Remove the transmitter from the tank or use a stilling well while pumping the liquid.

3.2.2 Installation in a Flowing Liquid

Fig 5 shows the installation method used in case of flowing liquid. For example, reservoir area, river channel.

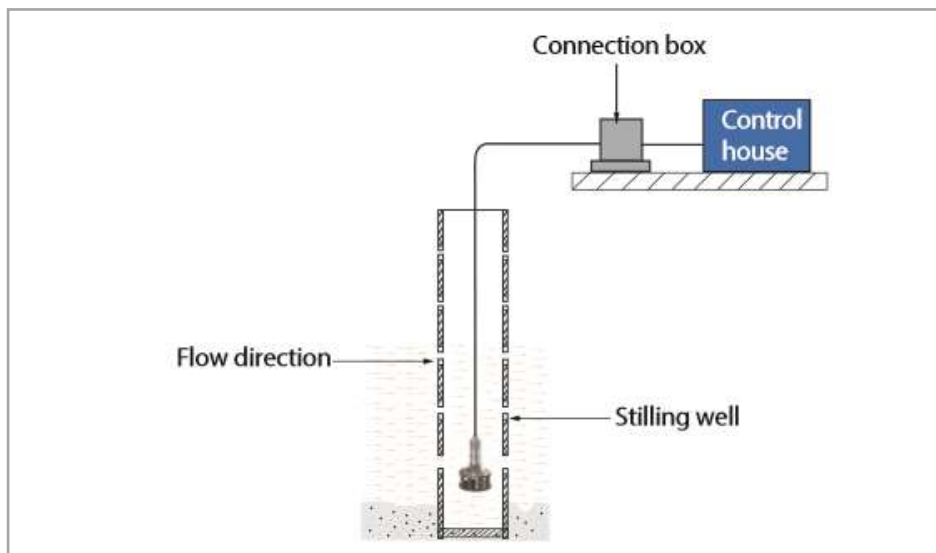

Fig.5. Installation in flowing liquid

A stilling well is recommended when there is a flowing liquid. A stilling well will dampen disruptions and provide a steady level for an accurate measurement.

#### 4 Electrical Connections

This section provides general information on the electrical connections of the Tek-Sub 4800D Wastewater Submersible Level Transmitter.

An external power supply delivering 12-30 VDC with minimum current capability of 40 mA DC (per transmitter) is required to power the control loop.

Fig.6 illustrates the connection of the power supply, transmitter and receiver.

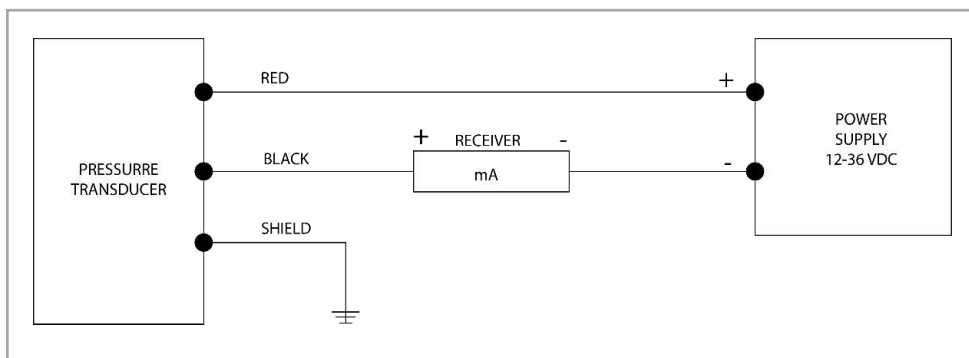

Fig.6. Power supply connections

The maximum receiver load resistance ( $R_{Lmax}$ ) for the DC power supply voltage ( $V_s$ ) is expressed as:

$$R_{Lmax} = V_s - 12V / 0.02A$$

Use of a shielded cable is recommended for control loop wiring.

Ensure proper ground connection. Improper grounding may lead to damage or poor signal integrity.

#### 4.1 Wiring Diagram

4~20mA/4~20mA+HART (2 wire)

Power+: Red

Signal+: Green

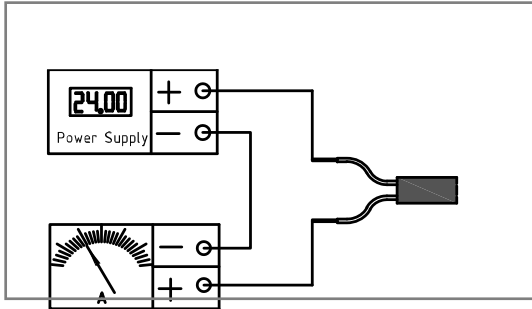

0~5VDC/1~5VDC/0.5~4.5V/0~10VDC (3 wire) RS485 (4 wire)

Power+: Red

Gnd: Green

Signal+: Yellow

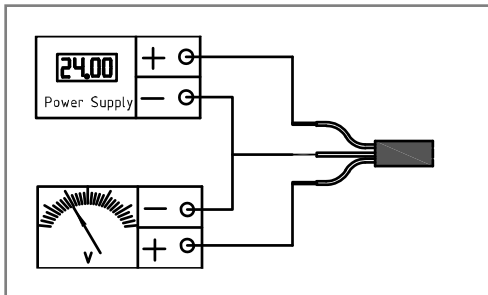

Power+: Red

Gnd: Green

485 A: Yellow

485 B: Blue

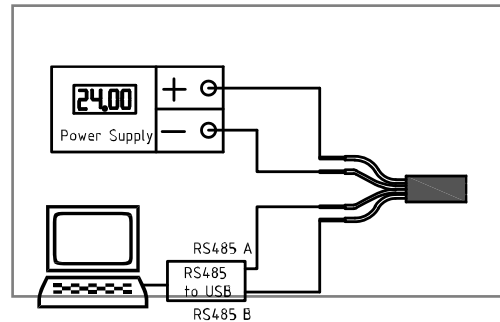

## 5 Operation

This section covers operation techniques and guidelines.

- The Tek-Sub 4800D Wastewater Submersible Level Transmitter can be operated without any adjustment.
- Make sure that the installation and electrical connections are done properly before operation.
- Connect the excitation and operate.
- Wait for at least 30 minutes after connecting the excitation for reliable output signal.

## 6 Maintenance

This section covers maintenance techniques and guidelines.

The Tek-Sub 4800D Wastewater Submersible Level Transmitter does not require regular maintenance, however the following points must be observed for better operation and reliability.

- Make sure that the wire connection is reliable.
- Make sure that the cable is not damaged.
- Clean the protection cap and diaphragm space regularly.
- Do not pull the cables violently or poke the diaphragm with metal objects

## 7 Troubleshooting

This section provides troubleshooting techniques for most common operating problems.

| Symptom                 | Corrective Action   |
|-------------------------|---|
| No Output or Low Output | Check the polarity of the terminals. Check for intermittent shorts, open circuits and multiple grounds. |
|                         | Check that the adequate voltage is supplied to the transmitter. The transmitter requires 12 to 36 VDC.  |
|                         | Verify sensor positioning and consider sensor cleaning.   |
| High Output             | Check for the dirty or defective terminals and interconnecting pins.                                    |
|                         | Check that the adequate voltage is supplied to the transmitter. The transmitter requires 12 to 36 VDC.  |
|                         | Check the sensor limits to ensure input to the sensor is within the range.                              |
| Erratic Output          | Check that the adequate voltage is supplied to the transmitter. The transmitter requires 12 to 36 VDC.  |
|                         | Check the polarity of the terminals. Check for intermittent shorts, open circuits and multiple grounds. |
|                         | Verify sensor positioning and consider sensor cleaning.   |

If error persists, contact Tek-Trol representative immediately.



TEKMATON LLC reserves the right to change the designs and/or materials of its products without notice. The contents of this publication are the property of  
TEKMATON LLC and cannot be reproduced by any other party without written permission. All rights reserved. Copying in 2021 by TEK-TROL LLC  
TEKMATON LLC  
DOC#TEKTIPS/MAIN/240320/4800D/00\_4



[www.tek-trol.com](http://www.tek-trol.com)

## **Tek-Trol LLC**

796 Tek Drive Crystal Lake,  
IL 60014, USA

 +1 847-857-6076

 [tektrol@tek-trol.com](mailto:tektrol@tek-trol.com)

 [www.tek-trol.com](http://www.tek-trol.com)

Tek-Trol is a fully owned subsidiary of TEKMATON LLC. We offer our customers a comprehensive range of products and solutions for process, power and oil & gas industries. Tek-Trol provides process measurement and control products for Flow, Level, Temperature & Pressure Measurement, Control Valves & Analyzer systems. We are present in 15 locations globally and are known for our knowledge, innovative solutions, reliable products and global presence.

Flow | Level | Temperature | Pressure | Valves | Analyzers | Accessories | TekValSys