



Technology Solutions

Tek-LCD 7804B

Explosion-Proof Modbus[®] Scanner

Instruction Manual



Disclaimer

The information contained in this document is subject to change without notice. Tek-Trol LLC makes no representations or warranties with respect to the contents hereof; and specifically disclaims any implied warranties of merchantability or fitness for a particular purpose.



CAUTION: *Read complete instructions prior to installation and operation of the controller.*



WARNING: *Risk of electric shock or personal injury.*



Warning!

- ***This product is not recommended for life support applications or applications where malfunctioning could result in personal injury or property loss. Anyone using this product for such applications does so at his/her own risk. Tek-Trol LLC shall not be held liable for damages resulting from such improper use.***
- ***Failure to follow installation guidelines could result in death or serious injury. Make sure only qualified personnel perform the installation.***
- ***Never remove the meter cover in explosive environments when the circuit is live.***
- ***Cover must be fully engaged to meet flameproof/explosion-proof requirements.***

Limited Warranty

Tek-Trol LLC warrants this product against defects in material or workmanship for the specified period under "Specifications" from the date of shipment from the factory. Tek-Trol's liability under this limited warranty shall not exceed the purchase value, repair, or replacement of the defective unit.

Registered Trademarks

Modbus® is a Registered Trademark of Schneider Automation Inc. All other trademarks mentioned in this document are the property of their respective owners.

www.tek-trol.com

Notice

Read this manual before working with the product. For personal and system safety, and for optimum product performance, make sure you thoroughly understand the contents before installing, using, or maintaining this product.

For technical assistance, contact

Customer Support

796 Tek-Drive

Crystal Lake, IL 60014

USA

Tel: +1 847 857 6076, +1 847 655 7428

© **COPYRIGHT Tek-Trol LLC 2018**

No part of this publication may be copied or distributed, transmitted, transcribed, stored in a retrieval system, or translated into any human or computer language, in any form or by any means, electronic, mechanical, manual, or otherwise, or disclosed to third parties without the express written permission. The information contained in this manual is subject to change without notice.

INTRODUCTION

The explosion-proof Tek-LCD 7804B is a serial input RS-485 Modbus® RTU scanner. These Modbus devices are ideal for hazardous areas or safe areas in need of a rugged solution.

Each can accept up to 16 Modbus process variables (PVs), from up to 16 devices. The scanners automatically cycle through the PVs, with the ability to manually cycle PVs or pause scanning.

A flow meter pulse input for rate, total, and grand total is standard. The total and grand total can display up to 13 digits with the total overflow feature.

Up to four math channels (CV1-CV4) may be used to perform math functions on any of the input variables. Math functions include sum, difference, weighted average, ratio and more. Nested math functions may be used in these math equations, allowing for complex math functions.

The display is programmable to show any input, math channel, units, or tags, on a variety of display combinations between the top and bottom displays.

Standard features include through-glass buttons for operating the scanner without removing the cover, a backlight that makes the display mode visible in any lighting condition, 512 points of input data logging, and two open collector pulse or alarm outputs. A 4-20 mA output is available as an option.

The enclosure is provided with three threaded conduit holes and integrated pipe or wall mounting flanges. One conduit plug is installed and included in the explosion-proof approvals.

ORDERING INFORMATION

Model	Description
Tek-LCD 7804B-AX0	Isolated 3-wire RS-485 with Modbus RTU protocol.

Accessories

Model	Description
Tek-LCD 7800A-PLUG75P	¾" Plastic Conduit/Stopping Plug
Tek-LCD 7800A-6846	Steel Pipe Mounting Kit
Tek-LCD 7800A-6846SS	Stainless Steel Pipe Mounting Kit

TABLE OF CONTENTS

INTRODUCTION	3
ORDERING INFORMATION	3
Accessories	3
TABLE OF CONTENTS	4
TABLE OF FIGURES	7
SPECIFICATIONS	8
General	8
Modbus Operating Modes	9
Serial Communications	9
Modbus Scanner Process Variables	10
Math Channels	10
Pulse Input	11
Pulse Rate/Totalizer	12
Open Collector Outputs	12
Product Ratings and Approvals	14
Electromagnetic Compatibility	15
SAFETY INFORMATION	15
INSTALLATION	16
Unpacking	16
Pre-Installed Conduit/Stopping Plug	16
Mounting	16
Cover Jam Screw	16
Connections	17
RS-485 Signal Connections	18
DC Power Connection.....	18
External Total Reset Connection	19
Open Collector Output Connections	19
Pulse Input Signal Connections	20
SETUP AND PROGRAMMING	22
Through-Glass Buttons	22
Buttons and Display	23
Button Operation	24
Setting Numeric Values	24
Setting Alphanumeric Labels	24
MAIN MENU	25
Display Functions & Messages	25
Main Menu Programming	29
Select Operating Mode (MODE)	29
Master Mode (MASTER)	30
PV Number Configuration (PV NUM).....	31
Enable/Disable PV (ENABLE, DISABLE).....	31
Slave ID (SLAVEID).....	31
Function Code (FUNCODE).....	31
Register Number (REG NUM).....	31
Data Type (DATATYPE)	32
Byte Format (BYTE).....	32
Poll Time (T_POLL).....	32
Response Timeout (TIMEOUT).....	32
Retries Before Error (RETRIES).....	33
Slave Mode (SLAVE)	33
PV Number Configuration (PV NUM).....	34

Enable/Disable PV (ENABLE, DISABLE)-----	34
Slave Response Timeout (TIMEOUT).....	34
Snooper Mode (SNOOPER)-----	34
Snooper Mode PV Configuration (PV_NUM).....	35
Snooper Mode Response Time (T_RESP).....	35
Setup the Display & Pulse Input (SETUP)-----	35
Setting Up the Display (DISPLAY)-----	36
Top Display (TOPDISP).....	36
Bottom Display (BOTDISP).....	37
PV Display Setup (PVSETUP).....	38
Modbus PV Display Format (FORMAT)-----	38
Enter Modbus PV Tag (TAG)-----	39
Enter Modbus PV Units (UNITS)-----	39
Set Float Data Type Decimal Point (FLOAT_DP)-----	39
Set Display Decimal Point (DISP_DP)-----	39
Scale Modbus PV to Engineering Units (SCALE)-----	40
Math Channel Display Setup (MATH).....	42
Math Display Format (FORMAT)-----	42
Enter Math Channel Tag (TAG)-----	42
Enter Math Channel Units (UNITS)-----	42
Set Display Decimal Point (DISP_DP)-----	43
Pulse Rate Display Setup (RATE).....	44
Rate Display Format-----	44
Enter Rate Tag (TAG)-----	44
Select Rate Time Base (T_BASE)-----	44
Select Rate Display Units (RATE_U)-----	45
Set Rate Display Decimal Point (RATE_DP)-----	46
Pulse Totalizer Display Setup (TOTAL).....	46
Total Display Format-----	46
Tag (TAG)-----	47
Total Units (TOT_U)-----	47
Set Total Display Decimal Point (TOTAL_DP)-----	48
Grand Totalizer Display Setup (Gr TOTAL).....	48
Grand Total Display Format-----	48
Grand Total Units (GrTOT_U)-----	49
Set Grand Total Display Decimal Point (GrTOT_DP)-----	49
Automatic Unit Conversions.....	50
Custom Units Entry (CUST)-----	50
Custom Rate, Total, and Grand Total Units Name (CUNITS, TUNITS, GrUNIT)-----	50
Custom Units Conversion Factor (RATE-CF, TOT-CF, Gr-CF)-----	50
Tank Indicator Tank Size (TANKSZ).....	51
Tag Display Time (T-TAG).....	51
Units Display Time (T-UNITS).....	51
Scan Time (T-SCAN).....	51
Setting Pulse Input Type (PULSEIN)-----	52
Input Level Selection Switch.....	52
Entering the K-Factor (KFACTOR)-----	53
Undoing K-Factor or Scale Programming (UNDO_P_KFACTOR)-----	54
K-Factor Units (F-UNIT).....	54
The K-Factor Custom Unit (P/VOL)-----	54
K-Factor Decimal Point (KF_DP).....	54
K-Factor Value (VALUE).....	54
Serial Communications Settings (COMM)-----	55
Scanner Modbus ID (SCAN_ID).....	55
Baud Rate (BAUD).....	55

Transmit Delay Time (TX DELAY).....	55
Parity (PARITY).....	55
ADVANCED MENU	56
Display Functions & Messages	56
Advanced Menu Programming (ADVANCE).....	60
Open Collector Outputs (OUTPUT)	61
Output 1 and 2 Setup (OUT 1, OUT 2)	61
Math Channel (CV1 to CV4) Programming (MATH)	66
Nested Math Functions.....	67
Entering a Constant Value.....	67
No Parameter (NONE).....	67
Gate Function (GATE)	67
Contact Debounce Filter (FILTER).....	68
Low-Flow Cutoff (CUTOFF).....	68
Pulse Input Scaling & Calibration (SCALECAL)	68
Undoing K-Factor or Scale Programming (UNDO KFACTOR).....	68
Scaling the Pulse Rate Input (SCALE).....	69
Calibrating the Pulse Rate Input (CAL).....	70
Total Reset (T RESET).....	70
Manual or Automatic Total Reset Function (TOTAL).....	71
Manual or Automatic Grand Total Reset Function (GTRESET).....	71
Setting Up Passwords (PASSWORD).....	72
Locking Scanner Setup Parameters (PASS).....	72
Making Changes to a Password Protected Scanner	72
Password Restricting Total & Grand Total Reset (PASS T, PASS GT)	72
Resetting Total & Grand Total on a Password Protected Meter.....	72
Disabling Password Protection	73
Non-Resetable Grand Total	73
Custom (CUSTOM).....	74
System (SYSTEM).....	76
Set Real Time Clock (SETTIME).....	76
Data Log Setup (DATALOG)	77
View Data Log (LOGVIEW).....	79
Backlight (BACKLITE).....	79
Analog Output Calibration (ANAL CAL).....	80
Backup & Restore (BACKUP).....	80
Information (INFO).....	80
OPERATION.....	81
Front Panel Buttons Operation.....	81
Pause/Start Automatic Scanning	83
Manual Scanning	83
Resetting the Total (TOTAL?)	83
Resetting the Grand Total (Gr TOTAL?).....	83
Reset Scanner to Factory Defaults	83
Factory Defaults & User Settings.....	84
TROUBLESHOOTING.....	88
Troubleshooting Tips	88
MOUNTING DIMENSIONS.....	89
QUICK USER INTERFACE REFERENCE.....	90
EU DECLARATION OF CONFORMITY.....	91

TABLE OF FIGURES

Figure 1: Connectors	17
Figure 2: RS-485 Three-Wire Serial Connections	18
Figure 3: RS-485 Five-Wire Serial Connections.....	18
Figure 4: DC Power Connections	18
Figure 5: Reset Connections	19
Figure 6: Open Collector Output Connections	19
Figure 7: Flowmeter Powered by External Supply (Active)	20
Figure 8: Isolated Flowmeter Powered by External Supply (ISO)	20
Figure 9: Self-Powered Magnetic Pickup Coil Flowmeter (Coil)	20
Figure 10: NPN Open Collector Input (NPN).....	21
Figure 11: PNP Sensor with External Power (PNP)	21
Figure 12: Switch Contact Input (Reed).....	21
Figure 13: Real Time Clock Display Example – Decimal Display Model	76
Figure 14: Real Time Clock Display Example – Feet & Inches Display Model	76
Figure 15: Enclosure Dimensions – Front View	89
Figure 16: Enclosure Dimensions – Side Cross Section View.....	89

SPECIFICATIONS

Except where noted all specifications apply to operation at +25°C.

General

DISPLAY	Five Digits Top Display (0 to 99999)	0.7" (17.8 mm) high, 7-segment, automatic lead zero blanking.
	Seven Characters Bottom Display	0.4" (10.2 mm) high, 14-segment, automatic lead zero blanking.
	Symbols	Total, grand total, high alarm, low alarm, through-glass button sleep mode/disable, password lock
DISPLAY ASSIGNMENT	<p>Top and Bottom Display*: Process Variables (PV); Alternating PV and Units, Tag and PV, or Tag, PV, and Units; Pulse Input Rate, Total, or Grand Total with Alternating Tag.</p> <p>Bottom Display: All Top Display Options or Off</p> <p>Units and tag independent for each PV, pulse input rate, total, and grand total.</p> <p>* On feet and inches display models, top display used only for level Modbus process variables or math channels.</p>	
BACKLIGHT	Backlight deactivated below temperatures $\approx -20^{\circ}\text{C}$	
ALARM INDICATION	Flashing display plus HI/LO (alarm) or SET indicators	
SCAN AND UPDATE RATE	<p>Ambient $> -20^{\circ}\text{C}$: Modbus PV scan rate programmable from 2 to 99 seconds per PV. Tag and units programmable for 1 to 5 second alternation. Pulse input variables update 1/second. Rate update is dependent on gate settings.</p> <p>Ambient $< -20^{\circ}\text{C}$: All Modbus scan, alternating units and tags, and pulse input variables update/10 seconds minimum.</p>	
UNDERRANGE	<p>Upper Display: Decimal display flashes -9999</p> <p>Level display flashes to 999^{FT} 1 1/16^{IN}</p> <p>Lower Display: Flashes -999999</p>	
OVERRANGE	<p>Upper Display: Decimal display flashes 99999</p> <p>Level display flashes to 999^{FT} 1 1/16^{IN}</p> <p>Lower Display: Flashes 9999999</p>	
PROGRAMMING METHODS	Four through-glass buttons when cover is installed. Four internal pushbuttons when cover is removed.	
PASSWORD MENU OPTIONS	<p>Three programmable password selections can be used for the following: restrict modification of settings, prevent resetting the total or grand total without the password, or permanently lock out the ability to change or reset the grand total or any grand total related settings (making a non-resettable grand total).</p> <p>Pass: Restricts modifications of programmed settings to require re-entering the password to make changes.</p> <p>Pass T: Restricts the reset of total to require re-entering the password. Disables the manual mode reset contact.</p> <p>Pass GT: Restricts the reset of grand total to Require re-entering the password. May enable a non-resettable grand total and permanent lockout of grand total-related settings with a specific password.</p>	
INPUT POWER	9-30 VDC, 38mA max. 2.2 W.	
DATA LOGGING	Up to 511 records, recorded 4/day at specific times or at defined time intervals. Record contains first eight enabled Modbus PVs; C1-4 if enabled; date; time; pulse rate, total, and grand total with units; and log number.	
ISOLATION	500 V opto-isolated pulse input-to-power/OC output with isolated input enabled. 500 V input/power-to-RS-485 serial communications	

ENVIRONMENTAL	Operating temperature range: -40 to 75°C Storage temperature range: -40 to 75°C Backlight deactivated below temperatures ≈ -20°C Relative humidity: 0 to 90% non-condensing
NON-VOLATILE MEMORY	All programmed settings and total reading are stored in non-volatile memory for a minimum of ten years if power is lost.
CONNECTIONS	Screw terminals accept 12 to 22 AWG wire
ENCLOSURE	Explosion-proof die-cast aluminum with glass window, corrosion resistant epoxy coating, color: blue. NEMA 4X, 7, & 9, IP68. Copper-free (0.3%). Default conduit connections: Three ¾" NPT threaded conduit openings. One ¾" NPT metal plug with 12 mm hex key fitting installed. Additional conduit opening configurations and plugs may be available; verify quantity and sizes on specific device labeling during installation.
MOUNTING	May be mounted directly to conduit. Two slotted flanges for wall mounting or NPS 1½" to 2½" or DN 40 to 65 mm pipe mounting. See MOUNTING DIMENSIONS on page 89.
DISPLAY ORIENTATION	Display may be mounted at 90° increments up to 270° from default orientation.
OVERALL DIMENSIONS	5.67" x 5.24" x 4.88" (W x H x D) (144 mm x 133 mm x 124 mm)
WEIGHT	5.00 lbs (80 oz, 2.27 kg)
WARRANTY	3 years parts and labor

Modbus Operating Modes

MASTER	Processes and displays data read from Modbus RTU slave devices. Up to 16 process variables (PVs) from up to 16 slave devices. Each PV programmed individually.
SLAVE	Processes data sent to it from a Modbus RTU master device. Note: Refer to Modbus Register Tables at www.tek-trol.com for details.
SNOOPER	Listens to the Modbus traffic and picks up a specific register or registers being polled by a Master device from a specific slave device and processes the data being read. Up to 16 process variables (PVs) from up to 16 devices. If multiple registers are polled by the master with one command, only the first returned value will be read.
MASTER POLL TIME	0.1 to 99.9 sec. Time between read-commands.
MASTER TIMEOUT	0.1 to 99.9 seconds. Time elapsed after a poll request is made before the scanner considers that request to have failed.
NUMBER OF RETRIES	1-99. The number of retries the scanner will make when requesting data before reporting an error condition on the PV.
SNOOPER RESPONSE TIME	0.1 to 99.9 seconds. Time since the last PV update the before being considered an error.
SLAVE TIMEOUT	0.0 to 99.9 seconds. Time elapsed after the last data received from a master before the scanner considers the data to be out of date. Programming 0 disables the timeout, and PV data will be displayed indefinitely despite not being updated regularly.

Serial Communications

PROTOCOL	3-Wire RS-485 Modbus® RTU
SCANNER ID	1 – 247. Specifies the address of the Tek-LCD 7804B.
BAUD RATE	1,200; 4,800; 9,600; 19,200; 38,400; 57,600; or 115,200 bps

TRANSMIT TIME DELAY	Programmable between 0 and 199 ms
PARITY/STOP BIT	Even, odd, none with 1 stop bit, or none with 2 stop bits
BYTE-TO-BYTE TIMEOUT	Max of 1.5-character times or 750 μ s

Modbus Scanner Process Variables

PV INPUTS	Up to 16 independently programmed Modbus process variables (PVs) may be scanned (Master mode) or detected (Snooper mode). Each of the 16 Modbus PVs may be enabled or disabled.
SLAVE ID	Specifies which device on the bus to monitor. Valid for Master and Snooper modes only. Assign the slave ID or address (1-247) of each of the devices containing the process variables to be displayed (Slave ID for PV1-16).
REGISTER NUMBER	Specifies which register(s) to read in the devices on the bus. 5 Digit Function 03: 40001–49999; 04: 30001–39999; or 65: 1–9999. 6 Digit Function 03: 400001–465535 or 04: 300001–365535; or 65: 1–65535. Range is dependent on Function Code selection (03, 04, or 65) Will read 2 registers for Long integer and Floating point data types; the register entered and the next consecutive register number. Valid for Master and Snooper modes only.
FUNCTION CODE	03, 04, and 65 (used to read 32 bit registers). Master & Snooper modes only.
DATA TYPE	Select the data format of the PVs. Select between short integer (2 byte), long integer (4 byte), or floating point (4 byte). Slave mode uses floating point only.
BYTE ORDER	Integer data programmable as binary or BCD, and signed or unsigned. Byte order selectable as big-endian (1234), little-endian (4321), byte swap big-endian (2143), or byte swap little-endian (3412). Byte swap unavailable for short.

Math Channels

MATH RESULT CHANNELS	Four math channels CV1-CV4. Each math channel may be programmed for a math function.																																																
MATH FUNCTIONS	Parameter 1 (PAR1), parameter 2 (PAR2), and parameter 3 (PAR3) independently programmable for each math channel C1-C4.																																																
	<table border="1"> <thead> <tr> <th><i>Math Function</i></th> <th><i>Function</i></th> <th><i>Setting</i></th> </tr> </thead> <tbody> <tr> <td>Addition</td> <td>PAR1 + PAR2</td> <td>SUM</td> </tr> <tr> <td>Difference</td> <td>PAR1 - PAR2</td> <td>DIF</td> </tr> <tr> <td>Multiplication</td> <td>PAR1 * PAR2</td> <td>MULTI</td> </tr> <tr> <td>Division</td> <td>PAR1 / PAR2</td> <td>DIVIDE</td> </tr> <tr> <td>Absolute diff.</td> <td>Abs(PAR1 - PAR2)</td> <td>DIFABS</td> </tr> <tr> <td>Weighted avg.</td> <td>((PAR1 - PAR2)*PAR3) + PAR2</td> <td>WAVG</td> </tr> <tr> <td>Draw</td> <td>((PAR1 / PAR2) - 1) * PAR3</td> <td>DRAW</td> </tr> <tr> <td>Ratio</td> <td>(PAR1 / PAR2) * PAR3</td> <td>RATIO</td> </tr> <tr> <td>Concentration</td> <td>PAR1 / (PAR1 + PAR2) * PAR3</td> <td>CONCEN</td> </tr> <tr> <td>Contant</td> <td>Constant</td> <td>CONST</td> </tr> <tr> <td>Long Integer</td> <td>Constant</td> <td>LONG</td> </tr> <tr> <td>Floating Pt.</td> <td>Constant</td> <td>FLOAT</td> </tr> <tr> <td>None</td> <td>Disable</td> <td>NONE</td> </tr> <tr> <td>Absolute Value</td> <td>Abs(PAR1)</td> <td>ABS</td> </tr> <tr> <td>Square Root</td> <td>$\sqrt{\text{PAR1}}$</td> <td>SQL</td> </tr> </tbody> </table>	<i>Math Function</i>	<i>Function</i>	<i>Setting</i>	Addition	PAR1 + PAR2	SUM	Difference	PAR1 - PAR2	DIF	Multiplication	PAR1 * PAR2	MULTI	Division	PAR1 / PAR2	DIVIDE	Absolute diff.	Abs(PAR1 - PAR2)	DIFABS	Weighted avg.	((PAR1 - PAR2)*PAR3) + PAR2	WAVG	Draw	((PAR1 / PAR2) - 1) * PAR3	DRAW	Ratio	(PAR1 / PAR2) * PAR3	RATIO	Concentration	PAR1 / (PAR1 + PAR2) * PAR3	CONCEN	Contant	Constant	CONST	Long Integer	Constant	LONG	Floating Pt.	Constant	FLOAT	None	Disable	NONE	Absolute Value	Abs(PAR1)	ABS	Square Root	$\sqrt{\text{PAR1}}$	SQL
<i>Math Function</i>	<i>Function</i>	<i>Setting</i>																																															
Addition	PAR1 + PAR2	SUM																																															
Difference	PAR1 - PAR2	DIF																																															
Multiplication	PAR1 * PAR2	MULTI																																															
Division	PAR1 / PAR2	DIVIDE																																															
Absolute diff.	Abs(PAR1 - PAR2)	DIFABS																																															
Weighted avg.	((PAR1 - PAR2)*PAR3) + PAR2	WAVG																																															
Draw	((PAR1 / PAR2) - 1) * PAR3	DRAW																																															
Ratio	(PAR1 / PAR2) * PAR3	RATIO																																															
Concentration	PAR1 / (PAR1 + PAR2) * PAR3	CONCEN																																															
Contant	Constant	CONST																																															
Long Integer	Constant	LONG																																															
Floating Pt.	Constant	FLOAT																																															
None	Disable	NONE																																															
Absolute Value	Abs(PAR1)	ABS																																															
Square Root	$\sqrt{\text{PAR1}}$	SQL																																															
PARAMETER SELECTION	Parameter 1 (PAR1), parameter 2 (PAR2), and parameter 3 (PAR3) selectable as: Modbus PV1-16, math channel C1-4, pulse input rate, total, grand total, or any math function.																																																

PARAMETER NESTED MATH	Defining parameter 1 or 2 as a math function will prompt for level 2 parameter 1 (L2P1), level 2 parameter 2 (L2P2), and/or level 2 parameter 3 (L2P3). Level 2 parameters function identically as parameter 1 and 2 for nested math functions.
------------------------------	---

Pulse Input

PULSE/ TRANSISTOR/ CONTACT CLOSURE INPUT	Field selectable; Sourcing or sinking pulse or square wave 0-5 V, 0-12 V, or 0-24 V; TTL; NPN or PNP transistor; Open collector 100 k Ω pull-up to 3 V; Switch contact 100 k Ω pull-up to 3 V; PNP transistor 100 k Ω pull-down to ground (COM) Active input 100 k Ω to battery level, 10 k Ω to power Maximum Frequency: 64 kHz Minimum Pulse Width: 5 μ s Threshold Setting Low (V) High (V) Normal 1.2 2.0 Low 0.2 1.2
OPTO-ISOLATED INPUT	Sourcing pulse or square wave 0-5 V, 0-12 V, or 0-24 V; Logic High: 2-24 V, Logic Low: < 1 V Maximum Frequency: 20 kHz Minimum Pulse Width: 20 μ s Input Current: 1 mA @ 5 V, 2.5 mA @ 12 V, 5 mA @ 24 V
LOW VOLTAGE MAG PICKUP INPUT	Sensitivity: 20 mVp-p to 24 Vp-p Maximum Frequency: 6 kHz
MINIMUM INPUT FREQUENCY	0.0001 Hz. Minimum frequency is dependent on high gate setting (rate display).
INPUT IMPEDANCE	Pulse input: Greater than 75 k Ω @ 1 kHz. Open collector/switch input: 100 k Ω pull-up to 3 V.
ACCURACY	\pm 0.03% of calibrated span \pm 1 count
PULSE INPUT RECALIBRATION	All ranges are calibrated at the factory to read frequency in Hz. No recalibration required.
TEMPERATURE DRIFT	Rate display is not affected by changes in temperature.
LOW-FLOW CUTOFF	0-99,999 (0 disables cutoff function)
DECIMAL POINT	Up to four decimal places or none: 44444, 33.333, 22222, 11111, or 00000
CALIBRATION	May be calibrated using K-Factor, scale without signal source, or by applying an external calibration signal.
K-FACTOR	Field programmable K-Factor converts input pulses to rate in engineering units. May be programmed from 0.000001 to 9,999,999 pulses/unit.
CALIBRATION RANGE	Input 1 signal must be \geq 1 Hz; input 2 signal may be set anywhere above input 1 setting. Minimum input span is 1 Hz. An Error message will appear if the input 1 and input 2 signals are too close together.
INPUT CONTACT DEBOUNCE FILTER	Programmable contact debounce filter. Input signal frequency speed selections of Hi (no filter), Med (250 Hz max input, 2 ms pulse width), and Low (100 Hz max input, 5 ms minimum pulse width).
TIME BASE	Second, minute, hour, or day
GATE	Low gate: 1-99 seconds; High gate: 2-9,999 seconds

Pulse Rate/Totalizer

DISPLAY ASSIGNMENT	The top display may be assigned to rate, total, or grand total, in addition to Modbus process variables.
RATE DISPLAY UNITS	Gallons, liters, imperial gallons, cubic meters, barrels, bushels, cubic yards, cubic feet, cubic inches, liquid barrels, beer barrels, hectoliters, or custom.
RATE DISPLAY TIME BASE	Rate display may be calculated in terms of units per second, minute, hour, or day.
TOTAL & GRAND TOTAL DISPLAY UNITS	Gallons, liters, imperial gallons, cubic meters, barrels, bushels, cubic yards, cubic feet, cubic inches, liquid barrels, beer barrels, hectoliters, or custom. Setting is independent for each.
TOTAL & GRAND TOTAL DISPLAY UNIT MULTIPLIER	x1, x100 (h), x1000 (k), or x1,000,000 (M) multiplier (and prefix) applied to total or grand total display units. Setting is independent for each.
TOTAL & GRAND TOTAL DECIMAL POINT	Up to six decimal places or none: 6.666666, 55.55555, 444.4444, 3333.333, 22222.22, 111111.1 or 0000000 Total and grand total decimal points are independently programmed, and are independent of rate decimal point.
TOTALIZERS	Calculates total and grand total based on rate and field programmable multiplier to display total in engineering units. Time base must be selected according to the time units in which the rate is displayed. The total and grand total utilize the same time base, with different conversion factors and resets.
TOTALIZER RESET	Via through-glass RESET button, mechanical button (cover off), external contact closure (total only), automatically via user selectable preset value and time delay (1 – 99,999 sec). Manual reset may be disabled or protected by password for the total and grand total. Total and grand total reset independently.
TOTAL OVERFLOW AND ROLLOVER	The total can display up to 9,999,999,999,999. Up to 9,999,999 can be displayed on the lower display normally. An overflow display will toggle between the first six digits and last seven digits (999999 <> 9999999) for a 13-digit total. The total will rollover beyond thirteen digits. The T indicator on the display will flash to indicate total overflow, and the six most significant digits (first six numbers of the total) are indicated with the flashing overflow symbol -<.
GRAND TOTAL OVERFLOW AND ROLLOVER	The grand total can display up to 9,999,999,999,999. Up to 9,999,999 can be displayed on the lower display normally. An overflow display will toggle between the first six digits and last seven digits (999999 <> 9999999) for a 13-digit total. The grand total will rollover beyond thirteen digits. The GT indicator on the display will flash to indicate grand total overflow, and the six most significant digits (first six numbers of the grand total) are indicated with the flashing overflow symbol -<.
EXTERNAL TOTAL RESET	External total reset connections are made between RST and COM. Logic High: 1.4 V, 3.3V max; Logic Low: < 0.8 V. 90 ms minimum pulse width.

Open Collector Outputs

OUTPUT ASSIGNMENT	Two open collector pulse outputs Out 1 and Out 2. Individually programmable for Modbus PV, math channel, pulse rate, total, or grand total alarms; Modbus PV, math channel, pulse rate, total, or grand total pulse outputs; or retransmitting of pulse inputs; constant timed pulse output; quadrature outputs (requires Out 1 and Out 2); or off.
RATING	Isolated open collector, off: 24 VDC max, on: <1 V @ 150 mA max
ALARM OUTPUT	Assign to Modbus PV 1-16, math channel 1-4, or rate for high or low alarm trip point. Assign to total or grand total for total or grand total alarms.

ALARM DEADBAND	0-100% FS, user selectable
ALARM ACKNOWLEDGE	Front panel ACK button resets output and screen indication.
PULSE OUTPUT COUNT	The pulse output count (COUNT) is programmable from 0.000001 to 9999999. PV and math channels generate a frequency equal to the PV or math value divided by the Count value. Rate pulses are generated at a rate of one output pulse per Count value. Total and grand total pulses are generated for every total or grand total increment selected. (e.g. Count value of 100 will generate one pulse every time the total is incremented by 100 units) Pulse rate retransmission outputs one to one for input pulses, up to maximum output speed. Count is not used for retransmitting outputs.
PULSE OUTPUT PULSE WIDTH	Unless otherwise stated, pulses are 50% duty cycle for required frequency. A pulse rate retransmit output will generate 100 to 130 μ s pulses at the falling edge of every input pulse.
PULSE OUTPUT MAXIMUM FREQUENCY	5 kHz, pulse width at 50% duty cycle. If the outputs exceed 5 kHz, the scanner will display <i>PULSE OVERRNG</i>
QUADRATURE OUTPUT	Output set to quadrature will lag the other pulse output by 90° (1/4 duty cycle) at output frequency. Minimum 1 Hz
TIMER OUTPUT	Programmable on and off time, repeating cycle. Minimum period 0.1 second, maximum 100,000 seconds. Minimum pulse time 0.01 second, maximum 10,000 seconds.

Product Ratings and Approvals

FM	Class I, Division 1, Groups B, C, D Class II, Division 1, Groups E, F, G Class III, Division 1; T6 Class I, Zone 1, AEx d IIC T6 Gb Zone 21, AEx tb IIIC T85°C Ta = -40°C to +75°C Enclosure: Type 4X & IP66 Certificate number: 3040391
CSA	Class I, Division 1, Groups B, C, D Class II, Division 1, Groups E, F, G Class III, Division 1; Ex d IIC T6 Enclosure Type 4X, IP66/68: Ta = -40°C to +75°C Certificate number: 2325749
ATEX	II 2 GD Ex d IIC T6 Gb Ex tb IIIC T85°C Db IP68 Tamb -40°C to +75°C ATEX Certificate: Sira 10ATEX1116X
IECEX	Ex d IIC T6 Gb Ex tb IIIC T85°C Db IP68 Ta = -40°C to +85°C IECEX Certificate: IECEX SIR 10.0056X

Special Conditions for Safe Use:

Use suitably certified and dimensioned cable entry device and/or plug. The equipment shall be installed such that the supply cable is protected from mechanical damage. The cable shall not be subjected to tension or torque. If the cable is to be terminated within an explosive atmosphere, then appropriate protection of the free end of the cable shall be provided.

Year of Construction

This information is contained within the serial number with the first four digits representing the year and month in the YYMM format.

For European Community

The Tek-LCD 7804B must be installed in accordance with the ATEX directive 94/9/EC, and the product certificate Sira 10ATEX1116X.

Electromagnetic Compatibility

EMISSIONS	EN 61326:2013 Safety requirements for measurement, control, and laboratory use – Industrial Group 1 Class A ISM emissions requirements
Radiated Emissions	Class A
IMMUNITY	EN 61326:2013 Safety requirements for measurement, control, and laboratory use
ESD	±4 kV contact, ±8 kV air
RFI – Amplitude Modulated	80-1000 MHz @ 10 V/m, 1.4-2.0 GHz @ 10 V/m, 2.0-2.7 GHz @ 10 V/m, 80% AM (1 kHz)
EFT	±2 kV DC mains, ±1 kV other
Telco Surge	±1 kV
CRFI	3 V, 0.15-80 MHz, 1 kHz 80% AM

SAFETY INFORMATION



WARNING

Read complete instructions prior to installation and operation of the scanner. Installation and service should be performed only by trained service personnel. Service requiring replacement of internal components (not including battery, if equipped) must be performed at the factory.

Disconnect from supply before opening enclosure. Keep cover tight while circuits are alive. Conduit seals must be installed within 18" (450mm) of the enclosure.

Verify that the operating atmosphere of the scanner is consistent with the appropriate hazardous locations certifications.

If the scanner is installed in a high voltage environment and a fault or installation error occurs, high voltage may be present on any lead

INSTALLATION

For Installation in USA: The Tek-LCD 7804B must be installed in accordance with the National Electrical Code (NEC) NFPA 70.

For Installation in Canada: The Tek-LCD 7804B must be installed in accordance with the Canadian Electrical Code CSA 22.1.

For European Community: The Tek-LCD 7804B must be installed in accordance with the ATEX directive 94/9/EC and the product certificate Sira 10ATEX1116X.



WARNING

Disconnect from supply before opening enclosure. Keep cover tight while circuits are alive. Conduit seals must be installed within 18" (450mm) of the enclosure.

Wiring connectors are accessed by opening the enclosure. Cover jam screw may need to be loosened on the cover. To access electrical connectors, remove the 2 captive screws, then disconnect the ribbon cable from the display module and set the display module aside.

Unpacking

Remove the scanner from box. Inspect the packaging and contents for damage. Report damages, if any, to the carrier. If any part is missing or the scanner malfunctions, please contact your supplier or the factory for assistance.

Pre-Installed Conduit/Stopping Plug

The Tek-LCD 7804B typically includes three ¾" NPT threaded conduit openings and one ¾" NPT metal conduit plugs with 12 mm hex key fitting installed. Additional conduit opening configurations and plugs may be available; verify quantity and sizes on specific device labeling during installation. The pre-installed plug and its installation are included in the hazardous area approvals.

The conduit/stopping plug included in a typical Tek-LCD 7804B has an internal 12 mm hexagonal socket recess for removal.



WARNING

In hazardous areas, conduit and conduit/stopping plugs require the application of non-setting (solvent free) thread sealant. It is critical that all relevant hazardous area guidelines be followed for the installation or replacement of conduit or plugs.

Mounting

The Tek-LCD 7804B has two slotted mounting flanges that may be used for pipe mounting or wall mounting. Alternatively, the unit may be supported by the conduit using the conduit holes provided. Refer to *Mounting Dimensions*, page 89 for details.



WARNING

Do not attempt to loosen or remove flange bolts while the scanner is in service.

Cover Jam Screw

The cover jam screw should be properly installed once the scanner has been wired and tested in a safe environment. The cover jam screw is intended to prevent the removal of the scanner cover in a flameproof environment without the use of tools. Using a M2 hex wrench, turn the screw clockwise until the screw contacts the scanner. Turn the screw an additional ¼ to ½ turn to secure the cover.



CAUTION

Excess torque may damage the threads and/or wrench.

Connections

 WARNINGS	<p>Static electricity can damage sensitive components. Observe safe handling precautions for static-sensitive components.</p> <p>Use proper grounding procedures/codes.</p> <p>If the scanner is installed in a high voltage environment and a fault or installation error occurs, high voltage may be present on any lead or terminal.</p>
--	---

To access the connectors, loosen the cover jam screw (if tightened) with an M2 hex wrench, remove the enclosure cover and unscrew the two captive screws that fasten the display module into the enclosure. Disconnect the ribbon cable and remove the display module. RS-485 serial connections are made to a removable terminal block on the back of the display module. Power and signal connections are made to a barrier terminal connector in the base of the enclosure. Grounding connections are made to the two ground screws provided on the base – one internal and one external. Use proper grounding techniques for explosion-proof areas and observe all local and national electric codes.

- D+ RS-485 data B (non-inverting) connection
- D- RS-485 data A (inverting) connection
- G RS-485 shield ground connection
- P+ DC Power positive terminal connection
- COM DC power supply input return/negative, reset contact closure common
- RST Contact closure reset pull-up to 1.8 VDC
- S+ Pulse signal input positive terminal connection
- S- Pulse signal input negative terminal connection
- OC1+ Open collector output 1 positive terminal
- OC1- Open collector output 1 negative terminal
- OC2+ Open collector output 2 positive terminal
- OC2- Open collector output 2 negative terminal

Refer to Figure 1 for terminal positions.

 WARNING	<p>Observe all safety regulations. Electrical wiring should be performed in accordance with all agency requirements and applicable national, state, and local codes to prevent damage to the scanner and ensure personnel safety.</p>
---	---

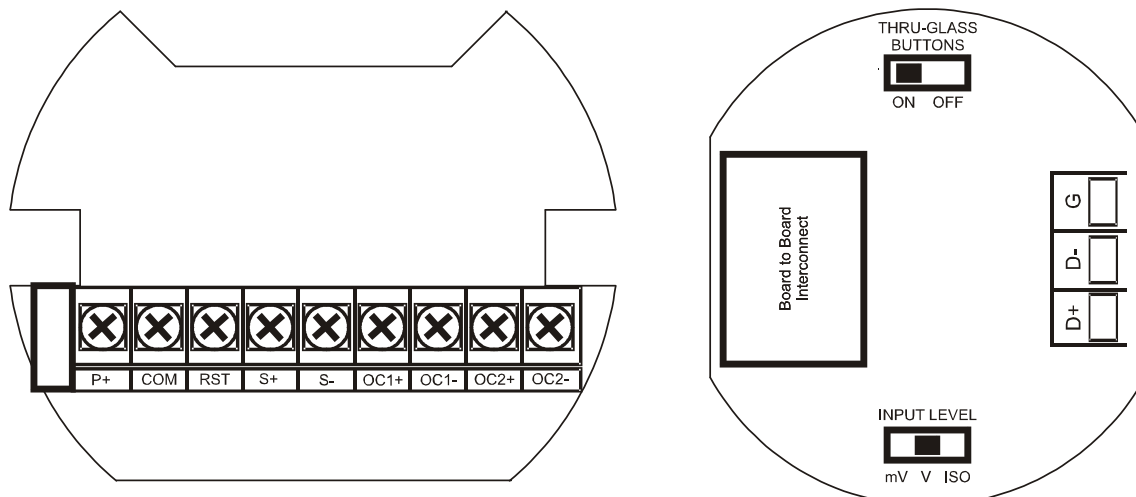

Figure 1: Connectors

RS-485 Signal Connections

The scanner includes a three-wire RS-485 serial connection. The cabling used for an RS-485 serial communications network should always be a high-quality cable such as Belden 8162 or Alpha 6203C. A three-wire system requires two twisted pairs (the extra twisted pair is needed for the signal ground).

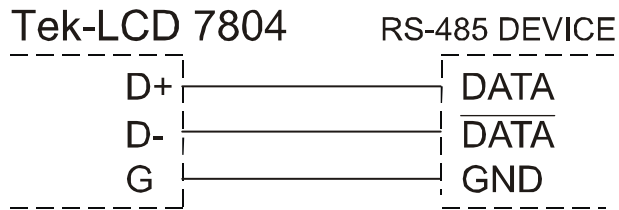

Figure 2: RS-485 Three-Wire Serial Connections

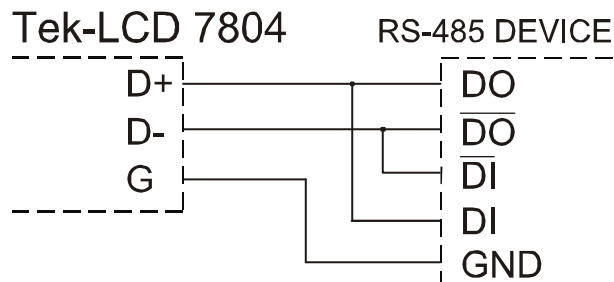

Figure 3: RS-485 Five-Wire Serial Connections

DC Power Connection

DC power is wired to terminals P+ and COM as shown in Figure 5. The same power supply may be used to power other circuits including a PNP-type sensor, however to maintain input isolation, a separate power supply must be used to power the Opto-Isolated Flowmeter as shown in Figure 8.

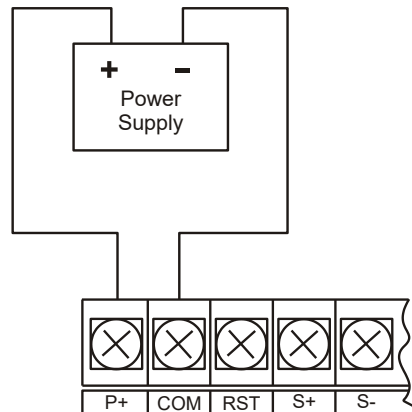

Figure 4: DC Power Connections

External Total Reset Connection

External total reset connections are made between RST and COM. Connect to a contact closure source such as a relay or a pushbutton as shown in Figure 5. Avoid extended contact closure to preserve battery life. The total is reset when the button is pressed. The scanner will start to totalize immediately. Holding down the button has no effect on the total.

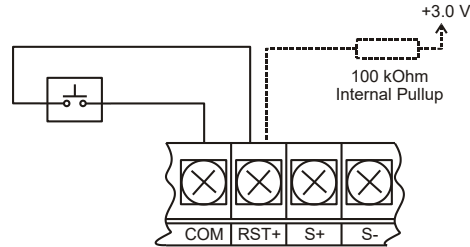

Figure 5: Reset Connections

Open Collector Output Connections

Open collector output 1 and 2 connections are made to terminals labeled OC1+ and OC1-, and OC2+ and OC2-. Connect the alarm or pulse input device as shown in Figure 6.

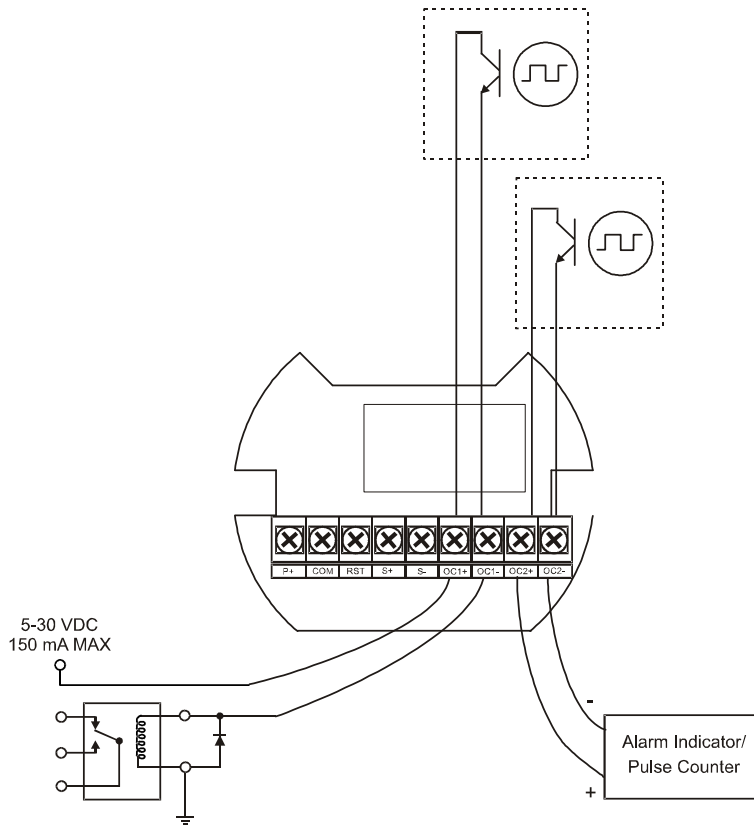

Figure 6: Open Collector Output Connections

Pulse Input Signal Connections

Signal connections are made to a barrier terminal mounted in the base of the enclosure. Input level and type are configured using the slide switches on the bottom of the display module as shown in the lower right of the following figures.

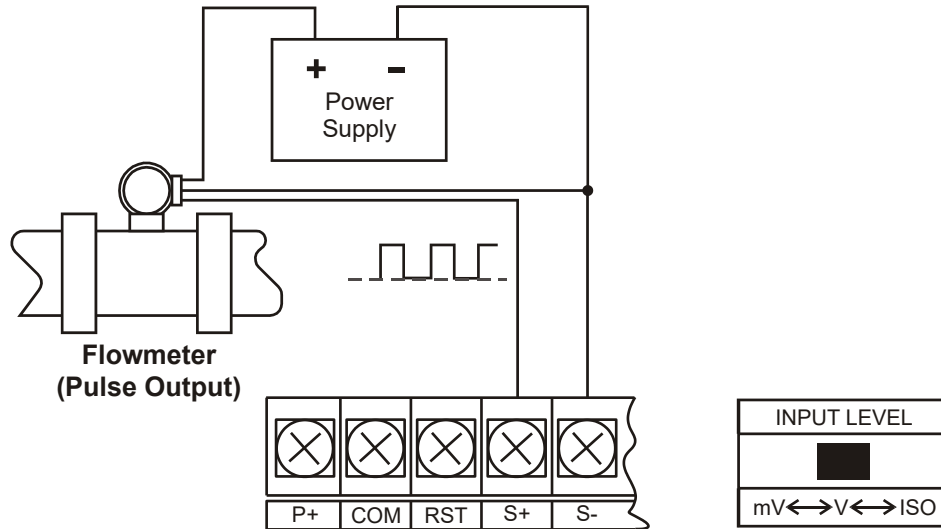

Figure 7: Flowmeter Powered by External Supply (Active)

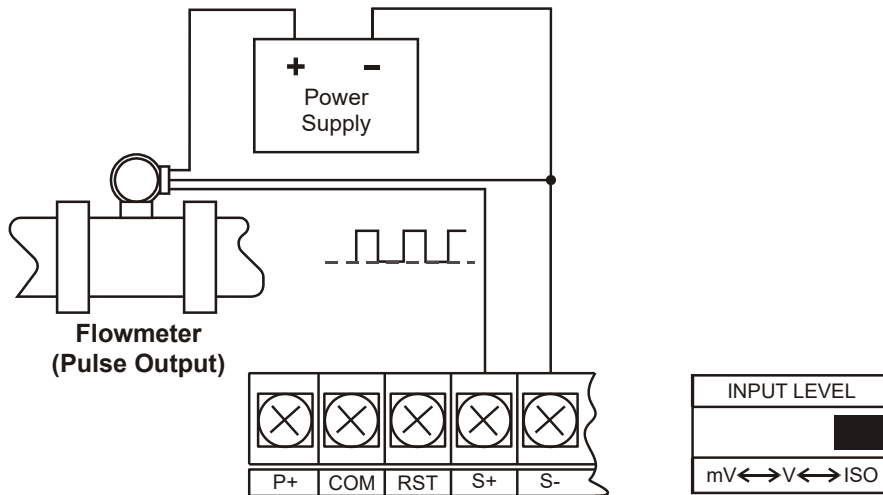

Figure 8: Isolated Flowmeter Powered by External Supply (ISO)

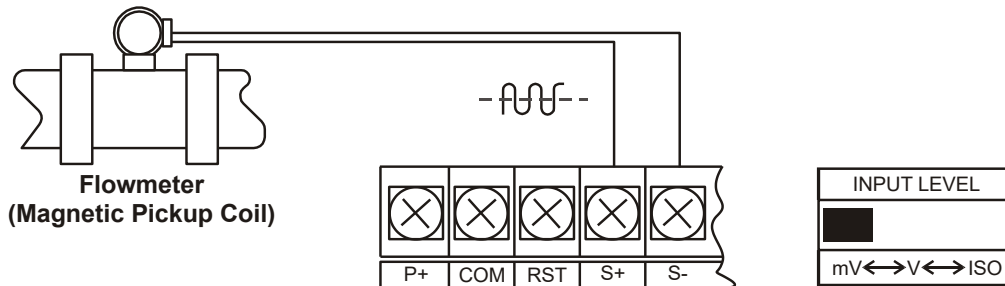

Figure 9: Self-Powered Magnetic Pickup Coil Flowmeter (Coil)

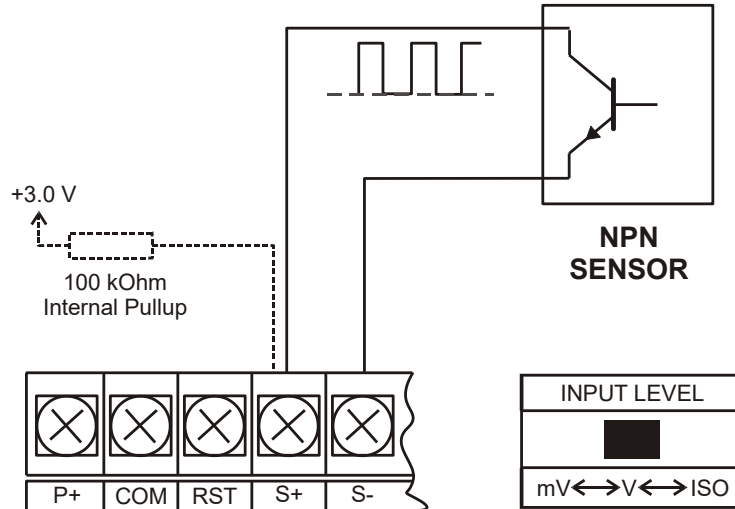

Figure 10: NPN Open Collector Input (NPN)

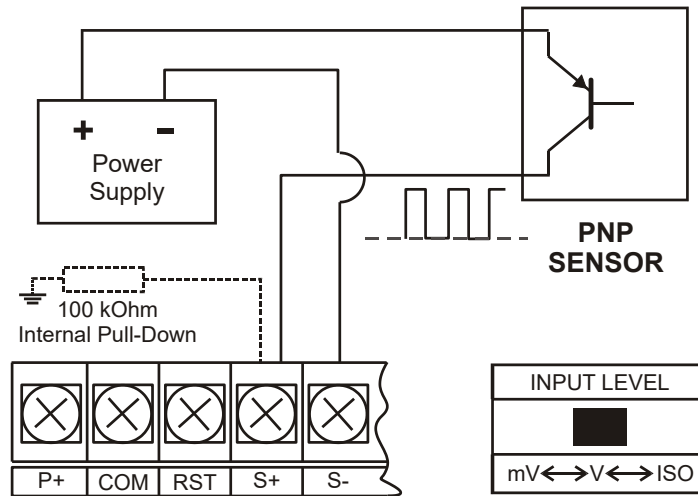

Figure 11: PNP Sensor with External Power (PNP)

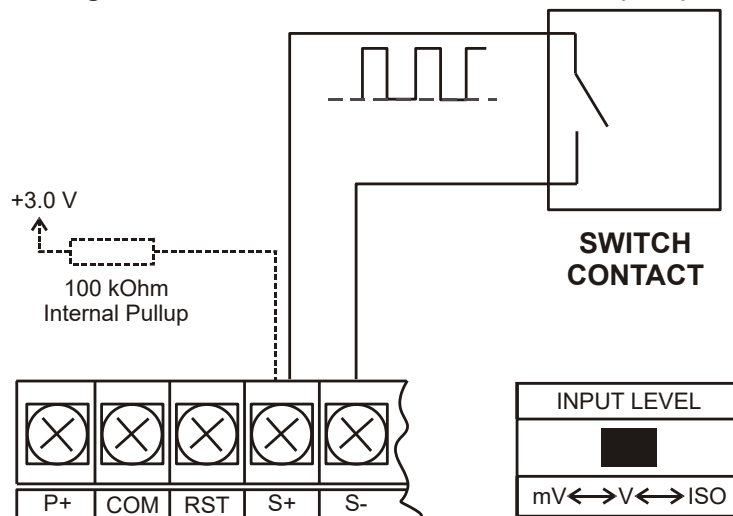

Figure 12: Switch Contact Input (Reed)

SETUP AND PROGRAMMING

Overview

Setup and programming is done through the infrared through-glass buttons, or using the mechanical buttons when uncovered. There are two slide switches located on the display module. One is used to configure the input and the other is to lock or unlock the through-glass buttons.

Through-Glass Buttons

The Tek-LCD 7804B is equipped with four sensors that operate as through-glass buttons so that it can be programmed and operated without removing the cover (and exposing the electronics) in a hazardous area. These buttons can be disabled for security by using the THRU-GLASS BUTTONS switch and selecting the OFF setting. This switch is located on the back of the removable electronics module.

Through-Glass Button Operation

To actuate a button, press and remove one finger to the glass directly over the marked button area. Remove finger to at least 4 inches away from the glass in between button activations. Through-glass and mechanical buttons may be held to cycle through menus or digits in place of repeatedly pushing a button.



Through-Glass Power Save Mode (Decimal Display -2 Models Only)

Through-glass buttons enter a power saving mode after three minutes of inactivity. This mode is indicated by a power symbol (⏻) appearing in the lower right of the display. Only the **MENU** button is monitored in this mode. To activate the through-glass buttons, press and hold the menu button for up to five seconds. The display will read **AWAKE**, and the through-glass buttons will be fully enabled.

Through-Glass Disabled Mode

When the cover is removed, the four mechanical buttons located next to the sensors may be used. The sensors are disabled when a mechanical button is pressed and will automatically be re-enabled after 60 seconds of inactivity. The through-glass power symbol (⏻) will blink in the lower right of the display if the buttons are disabled due to a mechanical pushbutton being pressed.

Through-Glass Button Equalize Delay

The through-glass buttons are designed to constantly recalibrate for ambient conditions. When the cover position is changed, the cover is removed, or an object is removed that was placed over the front window, it may take a moment for the through-glass buttons to recalibrate to the change in conditions.

Allow up to 2 minutes for the through-glass buttons to recalibrate to new conditions in these cases where the cover position was changed, or the front window is being unblocked.



IMPORTANT

Through-glass buttons will not work if two or more buttons are detected as being pressed simultaneously. As a result, be careful to avoid triggering multiple buttons or reaching across one button location to press another.

Through-Glass Button Tips and Troubleshooting

The through-glass buttons are designed to filter normal levels of ambient interference and to protect against false triggering, however it is recommended that the through-glass buttons be turned off (slide THRU-GLASS BUTTONS switch to OFF) if there is an infrared interference source in line-of-sight to the display or if the buttons are not needed.

Through-Glass Button Tips:

- To the extent possible, install the display facing away from sunlight, windows, reflective objects and any sources of infrared interference.
- Keep the glass window clean.
- Tighten the cover securely.
- Use a password to prevent tampering.
- If the cover has not been installed and secured tightly, it may take a moment for the through-glass buttons to properly self-calibrate when the cover is tightened.
- After all connections have been completed and verified, connect the ribbon cable to the display module, fasten the display module to the base, install enclosure cover, and then apply power.

Buttons and Display



Button Symbols	Description
	Menu/ Through-Glass Awake
	Previous PV, Right Arrow, or Total/Grand Total Reset
	Up Arrow or Next PV
	Enter or Start/Pause Scanning

Display Symbols	Description
HI	High Alarm
LO	Low Alarm
SET	Total Alarm
	Settings Lockout Password Enabled
	Through-Glass Power Save/Disable Flashing: Temporarily Disabled Due to Mechanical Button
T	Total Display Flashing: Total Overflow Indication
GT	Grand Total Display Flashing: Total Overflow Indication
	13 Digit Total Overflow, 6 Most Significant Digits

Button Operation

Menu Button

- Hold the **Menu** through-glass button when in power save mode (display will show ⏻) to awaken through-glass buttons.
- Press the **Menu** button to enter Programming Mode.
- Press the **Menu** button during Programming Mode to return to the previous menu selections.
- Hold the **Menu** button for 1.5 seconds at any time to exit Programming Mode and return to Run mode.
- Press and hold the **Menu** button for 3 seconds to access the *Advanced* features menu.

Right / Previous Button

- Press **Previous** to manually display the previous PV or input display.
- Press the **Right** arrow button in programming mode to move to the next digit or decimal position.
- Press the **Right** arrow button in programming mode to go backward through most selection menus.

Up / Next Button

- Press **Next** to manually display the next PV or input display.
- Press the **Up**-arrow button in programming mode to scroll forward through the menus, decimal point, or to increment the value of a digit.

Enter / Scan Button

- Press **Scan** to pause automatic scanning.
- Press **Scan** to resume automatic scanning when paused.
- Press the **Enter** button in programming mode to access a menu or to accept a setting.

Setting Numeric Values

The numeric values are set using the **Right** and **Up** arrow buttons. Press **Right** arrow to select next digit and **Up** arrow to increment digit.

The digit being changed blinks.

Press the **Enter** button, at any time, to accept a setting or **Menu** button to exit without saving changes.

The decimal point is set using the **Right** or **Up** arrow button in the *Setup, Decimal Point* menu.

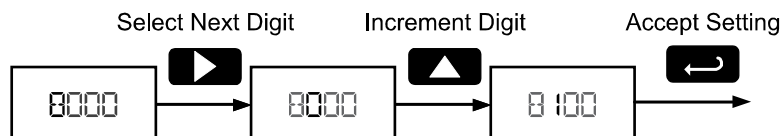

Setting Alphanumeric Labels

Fully alphanumeric values are set using the **Right** button to select the digit, the **Up** and **Right** arrow buttons to select the digit reading, and the **Enter** button to confirm and select the next digit.

Menus using this entering method include tags and custom units. After selecting the digit, and using the **Up** and **Right** arrows to modify the digit, the display will read [HR] . Using **Enter** to confirm the new digit and proceed to the next digit.

The digit being changed blinks.

Press the **Menu** button to exit without saving changes.

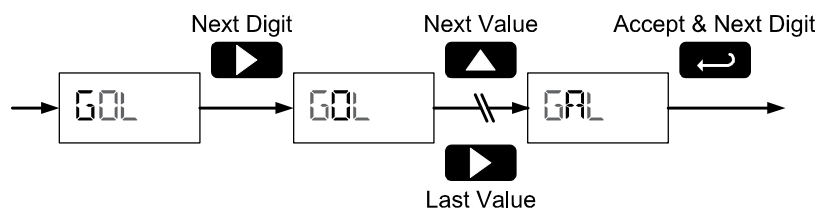

MAIN MENU

Display Functions & Messages

The scanner displays various functions and messages during setup, programming, and operation. The following table shows the main menu **MODE**, **SETUP**, and **COMM** menu functions and messages in the order they appear in the menu. Functions and messages that appear in the *Advanced* menu can be found in the **ADVANCED MENU** section on page 56.

Display	Parameter	Action/Setting
MODE	<i>Mode</i>	Enter <i>Mode</i> menu
MASTER	<i>Master Mode</i>	Select Master mode
PV NUM	<i>PV Number</i>	Enter the Modbus PV configuration menu
PV 1	<i>PV 1 – PV 16</i>	Enter PV1 to PV16 configuration menus
ENABLE	<i>Enable</i>	Enable the Modbus PV
SLAVEID	<i>Slave ID</i>	Enter the slave Modbus ID
FUNCODE	<i>Function Code</i>	Set the Modbus function code
REG NUM	<i>Register Number</i>	Enter the slave register number
DATATYP	<i>Data Type</i>	Set the data type
FLOAT	<i>Float</i>	Float data type
SHORT	<i>Short</i>	Short integer data type
LONG	<i>Long</i>	Long integer data type
BINARY	<i>Binary</i>	Binary integer type
BCD	<i>BCD</i>	Binary coded decimal integer type
UNSIGNED	<i>Unsigned</i>	Unsigned integer type
SIGNED	<i>Signed</i>	Signed integer type
BYTE	<i>Byte</i>	Select the byte format
1234	<i>1243</i>	Big endian
4321	<i>4321</i>	Little endian
2143	<i>2143</i>	Big endian with byte swap
3412	<i>3412</i>	Little endian with byte swap
DISABLE	<i>Disable</i>	Disable the Modbus PV
T POLL	<i>Poll Time</i>	Set the Modbus PV poll time
TIMEOUT	<i>Response Timeout</i>	Set Modbus communication response timeout
RETRIES	<i>Retries</i>	Set number of retries before display a PV communication error
SLAVE	<i>Slave</i>	Select Slave mode
PV NUM	<i>PV Number</i>	Enter the Modbus PV configuration menu
PV 1	<i>PV 1 – PV 16</i>	Enter PV1 to PV16 configuration menus
ENABLE	<i>Enable</i>	Enable the Modbus PV
DISABLE	<i>Disable</i>	Disable the Modbus PV
TIMEOUT	<i>Response Timeout</i>	Set Modbus response error time
SNOOPER	<i>Snooper Mode</i>	Select Snooper mode
PV NUM	<i>PV Number</i>	Enter the Modbus PV configuration menu
T RESP	<i>Response Time</i>	Set Modbus response error time
SETUP	<i>Setup Menu</i>	Enter <i>Setup</i> menu
DISPLAY	<i>Display</i>	Enter the <i>Display</i> menu

Display	Parameter	Action/Setting
TOPDISP	<i>Top Display</i>	Set the function of the top display
PV	<i>PV</i>	Display Modbus PV
PV-U	<i>PV & Units</i>	Display Modbus PV and units
TAG-PV	<i>Tag & PV</i>	Display Modbus PV and tags
TG-PV-U	<i>Tag, PV, & Units</i>	Display Modbus PV, tags, and units
BOTDISP	<i>Bottom Display</i>	Set the function of the bottom display
TAG	<i>Tag</i>	Display tags
TAG-U	<i>Tag & Units</i>	Display tags and units
OFF	<i>Off</i>	Turn off display
UNITS	<i>Units</i>	Display units
PV SETUP	<i>PV Setup</i>	Enter the <i>PV Setup</i> menu
PV-1	<i>PV-1 to PV-16</i>	Select PV to configure, PV 1 to PV16
FORMAT	<i>Format</i>	Enter PV display format
TOPDISP	<i>Top Display</i>	Display PV on top display
BOTDISP	<i>Bottom Display</i>	Display PV on lower display
OFF	<i>Off</i>	Turn off PV display
TAG	<i>Tag</i>	Enter the PV tag
UNITS	<i>Units</i>	Enter the PV units
DISPDP	<i>Display Decimal Point</i>	Set the PV display decimal point
FLOATDP	<i>Float Decimal Point</i>	Set the float decimal point location (if PV is float data type only)
SCALE	<i>Scale</i>	Select the PV display scaling
FACTOR	<i>Conversion factor</i>	Conversion factor scaling
LINEAR	<i>Linear</i>	Linear scaling
MP-SCALE	<i>Multipoint Scaling</i>	Multipoint scaling for PV1
MATH	<i>Math</i>	Enter <i>Math</i> menu (Will only appear if at least one math channel is enabled)
CV 1	<i>CV1 to CV4</i>	Select math channel to configure CV 1 to CV4
FORMAT	<i>Format</i>	Enter CV display format
TAG	<i>Tag</i>	Enter the CV tag
UNITS	<i>Units</i>	Enter the CV units
DISPDP	<i>Display Decimal Point</i>	Set the CV display decimal point
RATE	<i>Rate</i>	Enter the <i>Rate</i> menu
TOPDISP	<i>Top Display</i>	Display rate on the top display
BOTDISP	<i>Bottom Display</i>	Display rate on the bottom display
TAG	<i>Tag</i>	Enter the rate tag
T BASE	<i>Time Base</i>	Select the rate time base
MIN	<i>Minute</i>	Rate time base per minute
HOURL	<i>Hour</i>	Rate time base per hour
DAY	<i>Day</i>	Rate time base per day
SEC	<i>Second</i>	Rate time base per second
RATE U	<i>Rate Unit</i>	Enter the rate unit
GAL/M*	<i>Gallon/ Minute *</i>	Gallons per time base unit
L/M*	<i>Liter/ Minute *</i>	Liters per time base unit

Display	Parameter	Action/Setting
IGAL/M*	<i>Imperial Gallon/ Minute *</i>	Imperial Gallons per time base unit
M3/M*	<i>Meters³/ Minute *</i>	Meters cubed per time base unit
BBL/M*	<i>Barrel/ Minute *</i>	Barrel per time base unit
BUSH/M*	<i>Bushels/ Minute *</i>	Bushels per time base unit
CUYD/M*	<i>Cubic Yards/ Minute *</i>	Cubic yards per time base unit
CUFL/M*	<i>Cubic Feet/ Minute *</i>	Gallons per time base unit
CUIn/M*	<i>Cubic Inches/ Minute *</i>	Gallons per time base unit
LBBL/M*	<i>Liquid Barrels/ Minute *</i>	Gallons per time base unit
BBBL/M*	<i>Beer Barrels/ Minute *</i>	Gallons per time base unit
HECLL/M*	<i>Hectoliters/ Minute *</i>	Gallons per time base unit
CUST/M*	<i>Custom Volume/Minute*</i>	Custom volume/hour (enter custom rate conversion factor)
RATE_DP	<i>Decimal Point</i>	Set rate decimal point
OFF	<i>Off</i>	Turn rate display off
TOTAL	<i>Total</i>	Enter the <i>Total</i> menu
Gr TOTAL	<i>Grand Total</i>	Enter the <i>Grand Total</i> menu
TOPDISP	<i>Top Display</i>	Display total or grand total on the top display
BOTDISP	<i>Bottom Display</i>	Display total or grand total on the bottom display
TAG	<i>Tag</i>	Enter the total or grand total tag
TOT U	<i>Total Unit</i>	Enter the total tag
GTOT U	<i>Grand Total Unit</i>	Enter the grand total unit
GAL	<i>Gallons</i>	Gallons
L	<i>Liters</i>	Liters
IGAL	<i>Imperial Gallons</i>	Imperial gallons
M3	<i>Meters³</i>	Meters cubed
BBL	<i>Barrels</i>	Barrels
BUSH	<i>Bushels</i>	Bushels
CUYD	<i>Cubic Yards</i>	Cubic yards
CUFL	<i>Cubic Feet</i>	Cubic feet
CUIn	<i>Cubic Inches</i>	Cubic inches
LBBL	<i>Liquid Barrels</i>	Liquid barrels
BBBL	<i>Beer Barrels</i>	Beer barrels
HECLL	<i>Hectoliters</i>	Hectoliters
CUST	<i>Custom Volume</i>	Enter custom total or grand total unit
x 1	<i>x 1</i>	No total multiplier
x 100 h	<i>x 100 (h Prefix)</i>	Total multiplier one-hundred (h prefix)
x 1000 k	<i>x 1000 (k Prefix)</i>	Total multiplier of one-thousand (k prefix)
x 1000000 M	<i>x 10⁶ (M Prefix)</i>	Total multiplier of one-million (M prefix)
TOT-CF	<i>Total conversion factor</i>	Total conversion factor for custom units
TOTAL_DP	<i>Total decimal Point</i>	Set total decimal point
GT-CF	<i>Grand total conversion factor</i>	Grand total conversion factor for custom units
GRTOT_DP	<i>Grand total Decimal Point</i>	Set grand total decimal point
OFF	<i>Off</i>	Turn off total or grand total display

Display	Parameter	Action/Setting
TANKSZ	<i>Tank Size</i>	Enter tank level indicator full value (in feet for Ft & In version)
T--TAG	<i>Tag Time</i>	Enter tag display time
T--UNITS	<i>Units Time</i>	Enter unit display time
T--SCAN	<i>Scan Time</i>	Enter scan cycle time (e.g. PV dwell time)
PULSE.IN	<i>Input</i>	Enter <i>Pulse Input</i> type selection menu
ACTIVE	<i>Active</i>	Set active input type
NPN	<i>Npn</i>	Set NPN input type
PNP	<i>Pnp</i>	Set PNP input type
REED	<i>Reed</i>	Set reed switch input type
COIL	<i>Coil</i>	Set coil input type
ISO	<i>Isolated</i>	Set isolated input type
ACTLO	<i>Active Low</i>	Set active input type with low threshold
NPNLO	<i>NPN Low</i>	Set NPN input type with low threshold
PNPLO	<i>PNP Low</i>	Set PNP input type with low threshold
DISABLE	<i>Disable</i>	Disable pulse input features
KFACTOR	<i>K-Factor</i>	Enter the <i>K-Factor</i> menu
F-UNIT	<i>K-Factor Units</i>	Enter the K-Factor units
P/GAL	<i>Pulses/Gallon</i>	Set K-factor in pulses per gallon
P/L	<i>Pulses/Liter</i>	Set K-factor in pulses per liter
P/IGAL	<i>Pulses/Imp Gallon</i>	Set K-factor in pulses per imperial gallon
P/M3	<i>Pulses/Meter³</i>	Set K-factor in pulses per meter cubed
P/BBL	<i>Pulses/Barrel</i>	Set K-factor in pulses per barrel
P/BUSH	<i>Pulses/Bushel</i>	Set K-factor in pulses per bushel
P/cuYD	<i>Pulses/Cubic Yard</i>	Set K-factor in pulses per cubic yard
P/cuFT	<i>Pulses/Cubic Feet</i>	Set K-factor in pulses per cubic foot
P/cuIn	<i>Pulses/Cubic Inch</i>	Set K-factor in pulses per cubic inch
P/LIBBL	<i>Pulses/Liquid Barrel</i>	Set K-factor in pulses per liquid barrel
P/BBBL	<i>Pulses/Beer Barrels</i>	Set K-factor in pulses per beer barrel
P/HECCL	<i>Pulses/Hectoliter</i>	Set K-factor in pulses per hectoliter
P/VOL	<i>Pulses/Custom</i>	Set K-factor custom unit
KFDP	<i>K-Factor Decimal Point</i>	Set the number of decimal points in the K-factor
VALUE	<i>K-Factor Value</i>	Set the K-factor value for custom units
COMM	<i>Communications</i>	Enter the <i>Communications</i> menu
SCAN ID	<i>Scanner ID</i>	Enter the scanner's Modbus ID
BAUD	<i>Baud Rate</i>	Select baud rate
TXDELAY	<i>Transmit Delay</i>	Enter the transmit delay
PARITY	<i>Parity</i>	Select parity mode
EVEN	<i>Even</i>	Even parity
ODD	<i>Odd</i>	Odd parity
NONE 1	<i>None, 1 Stop Bit</i>	No parity, 1 stop bit
NONE2	<i>None, 2 Stop Bits</i>	No parity, 2 stop bits

* Rate time base shows as minute for example only.

Main Menu Programming

The main menu is used to navigate the programming menus and separates the most commonly used functions. The *Mode* menu is used to setup the scanner as a Modbus master, slave, or snoopers, and define Modbus PVs. The *Setup* menu is used to setup general scanner parameters, such as display assignments and the pulse input settings. The *Comm* menu configures the RS-485 serial communications settings. The *Advanced* menu is used to configure more complex settings not used with most common applications.

Press **Menu** button to enter Programming Mode then press the **Up**-arrow button to scroll through the main menu.

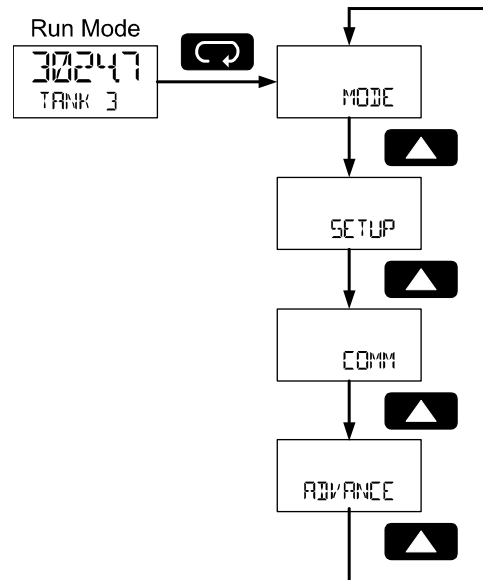

Press **Menu**, at any time, to return to the previous menu selection. Press and hold the **Menu** button for 1.5 seconds at any time to return to Run Mode.

Changes to the settings are saved to memory only after pressing **Enter**.

The display moves to the next menu every time a setting is accepted by pressing **Enter**.

 IMPORTANT	<p>The Advanced menu contains parameters not required for all applications. The setup of features and functions detailed in the Advanced features menu are found in the Advanced Menu Programming (ADVANCE) section on page 60.</p>
----------------------	---

Select Operating Mode (MODE)

The *Mode* menu is used to select master, slave, or snoopers operating mode. Only one of these modes may be used. The programming of each mode is detailed below.

Master mode is used to configure the scanner as a Modbus master. It will poll up to 16 registers in up to 16 Modbus slave devices. Slave mode is used to configure the scanner as a Modbus slave. A Modbus master must be used to send data to the Modbus registers of the scanner for display. Snooper mode is used to listen for data polled by a Modbus master on the Modbus network. The scanner will detect up to 16 Modbus registers polled by the master.

Press the **Enter** button to access any menu or press the **Up**-arrow button to scroll through choices. Press the **Menu** button to back out of a menu or hold the **Menu** button to exit at any time.

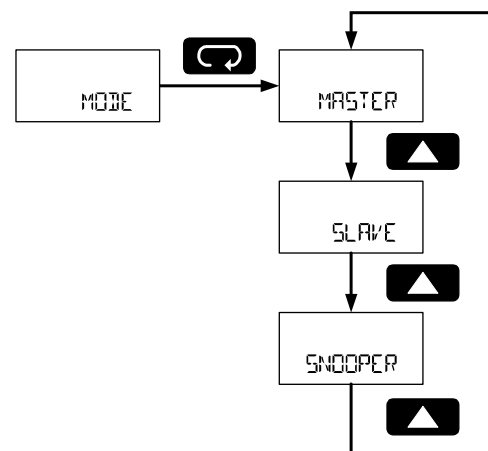

Master Mode (MASTER)

In Master mode, the scanner will poll up to 16 Modbus registers in up to 16 Modbus devices. It will serve as a Modbus network master; polling Modbus slave devices for Modbus process variables (PVs) that can be displayed or used in the math functions.

Programming the Modbus Master mode will include defining the Modbus PV registers and devices, selecting the polling time interval, and the maximum response time allowed.

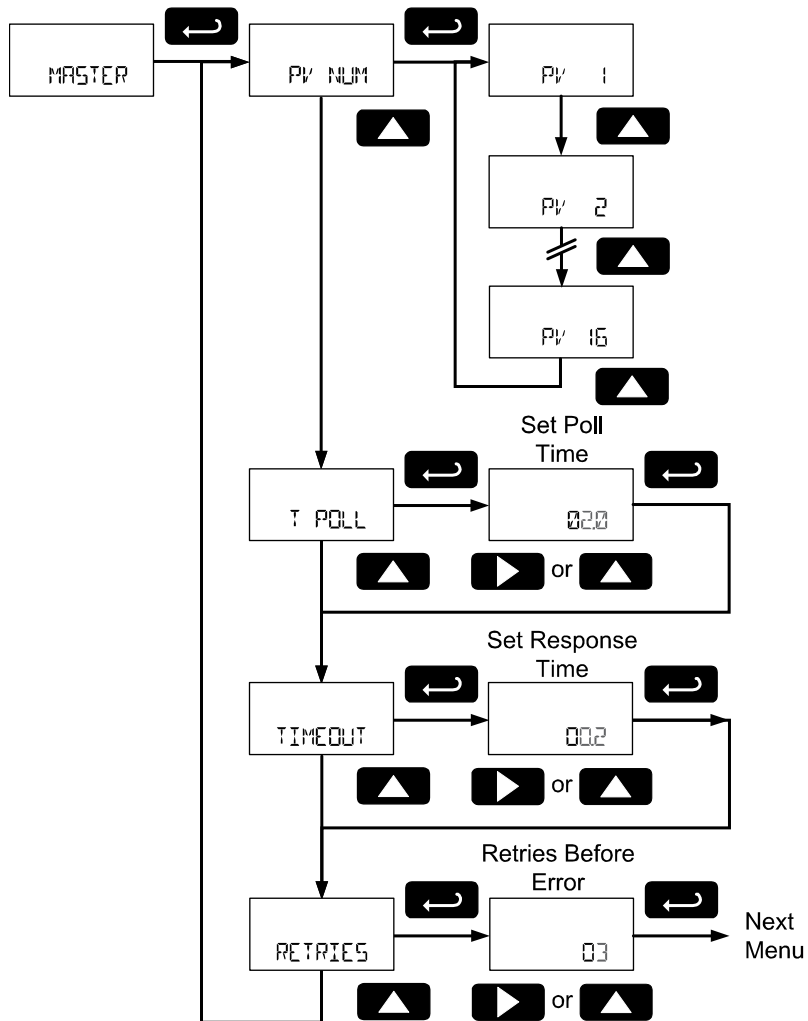

PV Number Configuration (PV NUM)

The *PV Number* menu is used to enable and disable each Modbus PV 1 to 16. The Modbus device and registers are configured for each of the enabled PVs. PVs that are not enabled will not appear in other programming menus for display or inclusion in math channel functions (CV).

PV1 to PV16 are programmed in identical menus.

Note: To enable a PV it must be assigned to a specific slave ID.

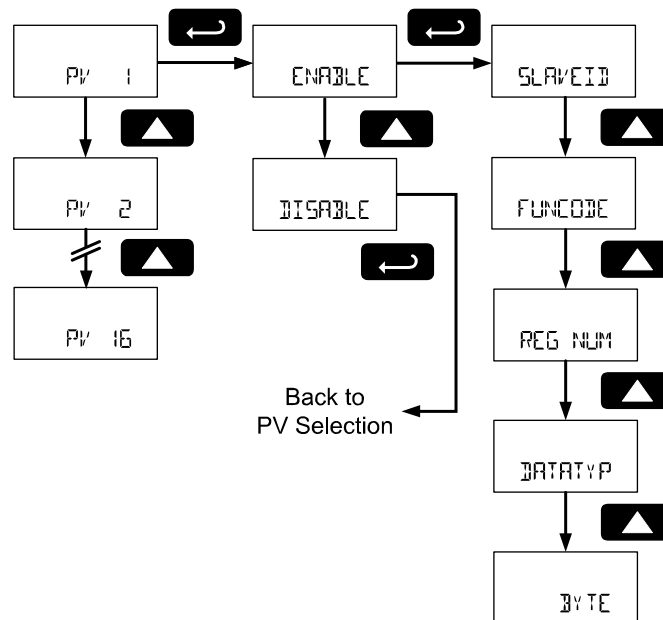

Enable/Disable PV (ENABLE, DISABLE)

Enable or disable the Modbus PV. Disabled PVs will require no additional configuration. Disabled PVs will not be accessible in other menus or functions.

Slave ID (SLAVEID)

Enter the Modbus ID of the slave device that contains the PV information.

Function Code (FUNCODE)

Select the Modbus function code necessary to read the device. Use the **Up** and **Down** arrows to select the appropriate function code, and press **Enter** to accept the function code.

See the Tek-LCD 7804B *Modbus Register Table* available at www.tek-trol.com for more information on function codes.

Register Number (REG NUM)

Enter the Modbus register number of the PV information on the Modbus slave device defined in the *Slave ID* parameter.

Data Type (DATATYPE)

Enter the data type of the PV information in the Modbus register. Selectable data types are float, short integer, and long integer. Use the **Up** and **Down** arrows to select the appropriate data type and press **Enter** to accept.

For short and long integer types, select binary or binary coded decimal (BCD) formats as well as signed or unsigned data format.

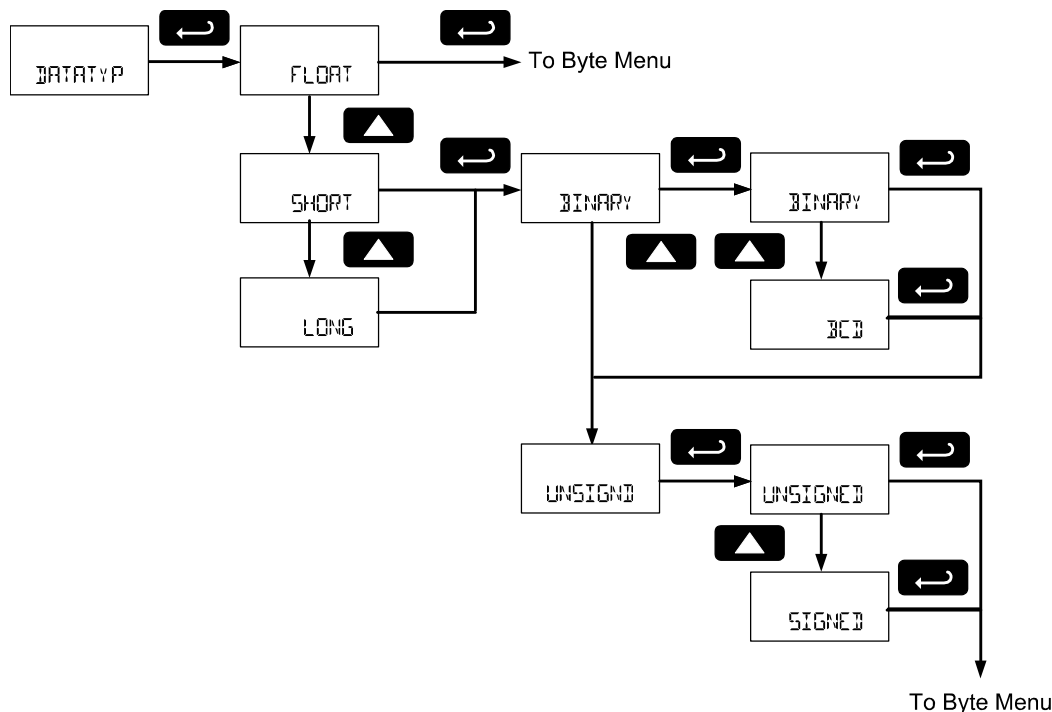

Byte Format (BYTE)

Select the PV data byte format as it is stored in the Modbus slave device data register. Use the **Up** and **Down** arrows to select the appropriate data type related to endianness and byte order.

Byte Selection	Byte Type	Description
1234	1234	Big endian
4321	4321	Little endian
2143	2143	Big endian with byte swap
3412	3412	Little endian with byte swap

Poll Time (T_POLL)

Enter the time between read command sequences. In other words, how often the display values are updated in Master mode. The poll time defines how often the device will begin scanning all enabled Modbus PVs. For example, if the *Poll Time* is two seconds, the scanner will begin polling all Modbus PVs every two seconds.

This parameter defines the approximate time between updates of a PV value. Communications errors may make updating a PV take longer.

Note: Depending on the Response Timeout, and the number of PV poll requests that time out, it may take more than one poll time to poll all enabled Modbus PVs. In this scenario, the scanner will begin another round of polling at the next poll time interval.

For example: Due to transmission errors, the scanner with a 2 second poll time requires 2.5 seconds to update all the Modbus PVs. It will begin the second polling all the Modbus PVs at 4 seconds.

Note: The feet and inches display models enter this value in the format XX.X seconds, but no decimal point is present in the display. For example: enter 20 for a poll time of 2.0 seconds.

Response Timeout (TIMEOUT)

Enter the time the scanner will wait after a request for information has been sent to a slave device before it will assume an error on that request. Increasing the timeout will help eliminate polling errors when

polling slow devices. Increasing the response timeout will also slow the PV update rate in systems that are experiencing communications failures.

Note: The feet and inches display models enter this value in the format XX.X seconds, but no decimal point is present in the display. For example: enter 20 for a poll time of 2.0 seconds.

Retries Before Error (RETRIES)

Enter the number of consecutive failures to poll a device that will result in a communications error message on the display. This is the number of times a specific PV must be polled before the display indicates a communication failure rather than displaying the available PV data. Increasing this number will allow for more polling failures before a communication error is detected, which may be required for some unreliable networks. Increasing this number will also increase how long old data is displayed before a communication error is indicated.

Slave Mode (SLAVE)

In Slave mode, a Modbus master may write up to 16 Modbus PVs to the scanner, which can then display and process the data in the PV Modbus registers, such as displaying the data and using them in math functions.

Programming the scanner for Modbus Slave mode will include defining the Modbus PV registers that are enabled, as well as selecting the time between data writes before an error is assumed. In Slave mode the scanner accepts floating point data (Byte order: 1234 big endian).

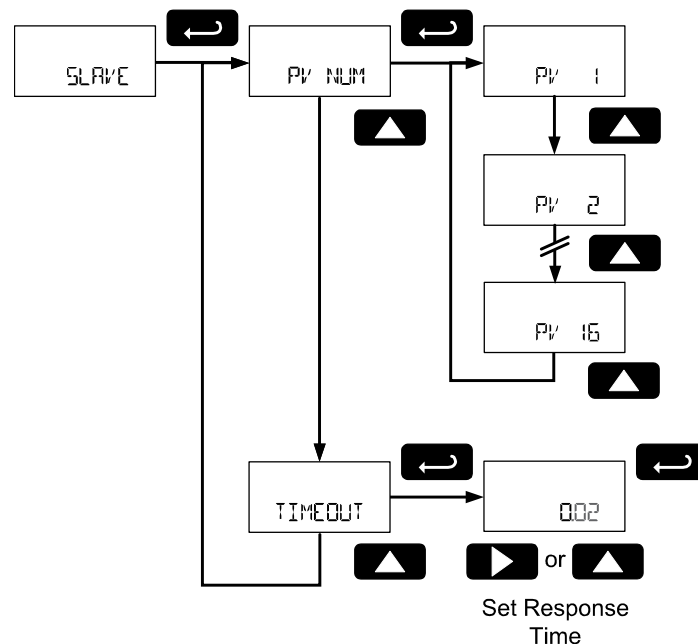

PV Number Configuration (PV NUM)

The *PV Number* menu is used to enable and disable each Modbus PV 1 to 16. PVs that are not enabled will not appear in other programming menus for display or inclusion in math channel functions (CV). PV1 to PV16 are programmed in identical menus.

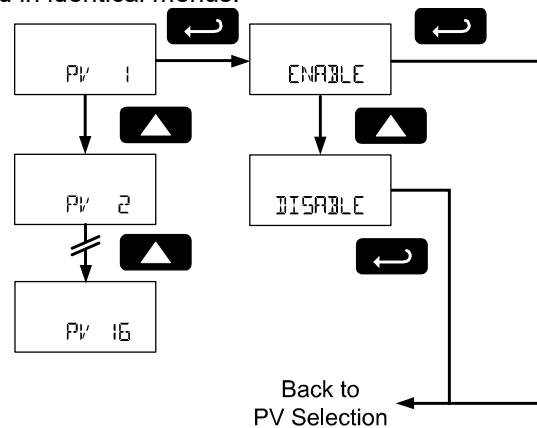

Enable/Disable PV (ENABLE, DISABLE)

Enable or disable the Modbus PV. Disabled PVs will require no additional configuration. Disabled PVs will not be accessible in other menus or functions.

The Slave mode accepts float data type (Byte order: 1234 big endian).

Slave Response Timeout (TIMEOUT)

If the Modbus data registers for the enabled Modbus PVs are not updated within a certain period of time, the scanner can presume that there is an error with the data, or that it is too out of date to be worth displaying. In this case, the scanner will display this PV as NONE (NONE).

At the *Response Timeout* menu, enter the time limit for the scanner to continue to display data written to the Modbus PV register. To disable this feature, and always display the last data written to the Modbus register regardless of how long ago the data was updated, set this value to 0 seconds.

Snooper Mode (SNOOPER)

In Snooper mode, the scanner will act as a Modbus network packet sniffer. The Snooper mode is used to listen to data being transmitted on the bus. Up to 16 process variables may be read from the RS-485 bus and displayed or used in math functions. The same process variables can be displayed in multiple locations.

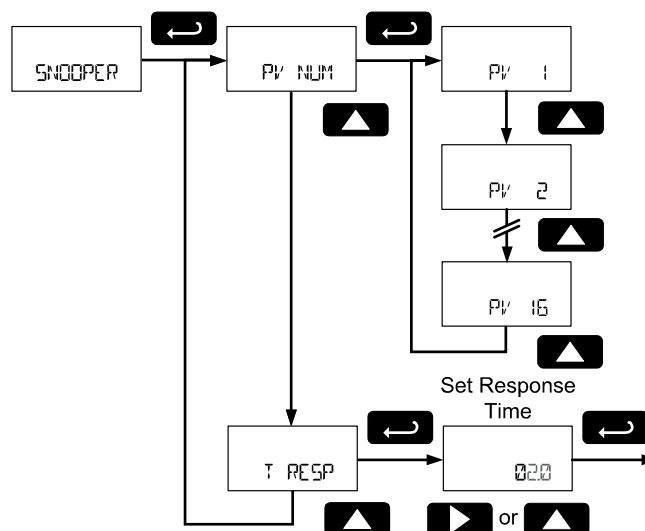

Notes:

The poll time for scanners set up for Snooper mode must be greater than the Master's poll time. This setting corresponds to the time window during which the Snooper listens to the bus for a reply by the slave device being polled by the master device. As soon as the Snooper detects a new reply on the bus, the display is updated. If there is no reply within the Response Time setting, the Snooper goes into communications break condition.

If multiple registers are polled by the master with one command, only the first returned value will be read. To minimize the possibility of communication errors and communication break conditions, use a poll time of 5 seconds or more with slow baud rates (e.g. 4800 bps or less).

Snooper Mode PV Configuration (PV NUM)

The PV Number menu is used to enable and disable each Modbus PV 1 to 16. This menu is identical in Master mode. Refer to PV Number Configuration (PV NUM) on page 31.

Snooper Mode Response Time (T RESP)

If the Modbus data registers for the enabled Modbus PVs are not updated within a certain period of time, the scanner can presume that there is an error with the data. After this time has passed, and updated data has not been detected on the Modbus network, the scanner will display this PV as NONE (NONE).

At the Response Time menu, enter the time limit the scanner will display the Modbus PV register last data monitored before it assumes an error.

Setup the Display & Pulse Input (SETUP)

The Setup menu is used to select what information will be displayed on the top and bottom display and to configure the pulse input.

The Display menu is used to select the top and bottom display to show Modbus PVs, pulse input rate, total, or grand total, math channels, and combinations of units and tags. The math channels are configured in the Advanced Features menu.

The Pulse Input menu and K-Factor menus are used to configure the pulse input.

Press the **Enter** button to access any menu or press the **Up**-arrow button to scroll through choices. Press the **Menu** button to back out of a menu or hold the **Menu** button to exit at any time.

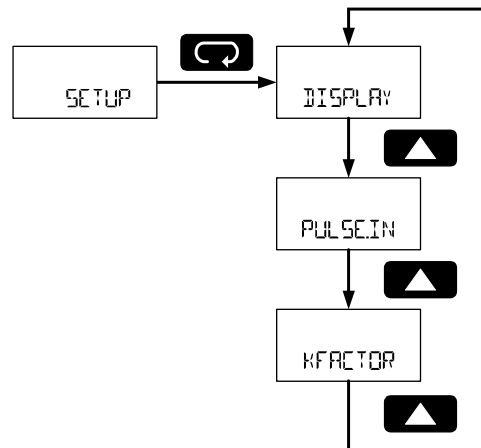

Setting Up the Display (DISPLAY)

The *Display* menu is used to set parameters to show on the top and bottom displays; select which PVs will appear on the top and bottom displays; configure the rate, total, and grand total; set how long to display the tags and units; and program the scan time for each channel (how long a specific channel will display before moving to the next value).

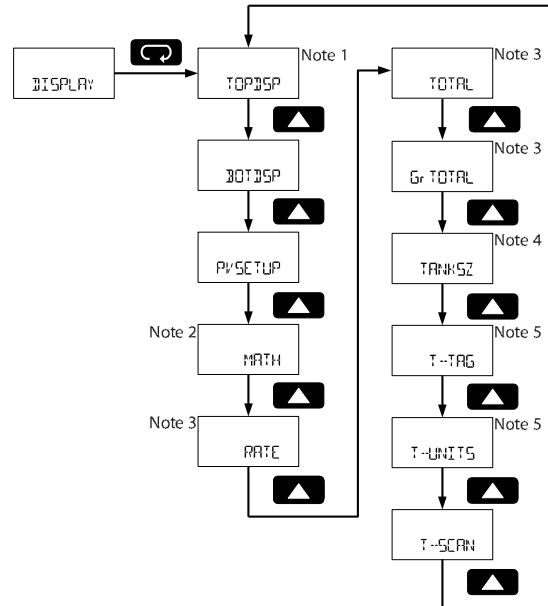

Note 1: The Top Display menu does not appear on feet and inches display models.

Note 2: The math menu (MATH) is only visible if a math channel has been enabled. See Math Channel (CV1 to CV4) Programming (MATH) on page 66 for details about enabling the math channels.

Note 3: The Rate, Total, and Grand Total Display menus will not appear if the Pulse Input Setup parameter (PUL SECTM) is set to disable.

Note 5: The Tank Size menu appear only in Feet and Inches Display Models.

Note 4: The Tag Time and Units Time menus will not appear unless the Top Display or Bottom Display parameters are set to display or alternate a tag or unit.

Top Display (TOPDISP)

Note: The Top Display menu does not appear on feet and inches display models.

The *Top Display* menu sets what Modbus PV information will be displayed on the top display. A combination of Modbus PVs, tags, and units can be selected to appear individually or as an alternating display.

The display of rate, total, and grand total is programmed in the *Rate*, *Total*, and *Grand Total Display* menus.

See *PV Setup* menu for details on selecting what Modbus PVs appear on the top and bottom display.

Press **Enter** to access the *Top Display* menu and **Up** button to scroll through choices. Press **Enter** to make a selection and proceed to the next menu.

Press the **Menu** button to back out of a menu, or hold the **Menu** button to exit at any time.

Top Display Selection	Parameter	Description
PV	PV	Display Modbus PVs
PV-U	PV and Units	Display alternating Modbus PVs and units
TAG-U	Tag and Units	Display alternating tags and units for bottom Modbus PVs
TAG-PV	Tag and PV	Display alternating tag and Modbus PVs
TG-PV-U	Tag, PV, and Units	Display alternating tag, Modbus PVs, and units

Note: Some top display selections may not appear if no PV is assigned to display on the top display.

Bottom Display (BOTDISP)

The *Bottom Display* menu sets what Modbus PV information will be displayed on the bottom display. The available programming options for the bottom display are determined by the *Top Display* menu setting. For level display models, the selections for the *Bottom Display* menu are fixed. A combination of Modbus PVs, tags, and units can be selected to appear individually or as an alternating display.

A selection without a PV component will use the bottom display to show the unit or tag of the PV displayed on the top display. These will change as the top display PVs are scanned.

The display of rate, total, and grand total is programmed in the *Rate*, *Total*, and *Grand Total Display* menus.

See *PV Setup* menu for details on selecting what Modbus PVs appear on the top and bottom display.

Press **Enter** to access the *Bottom Display* menu and **Up** button to scroll through choices. Press **Enter** to make a selection and proceed to the next menu.

Press the **Menu** button to back out of a menu, or hold the **Menu** button to exit at any time.

Top Display Selection	Bottom Display Selection	Parameter	Description
All Level Display Models	TAG	Tag	Display tag
	TAG-U	Tag and Units	Display alternating tag and units
	UNITS	Units	Display units
	PV	PV	Display Modbus PVs
	TG-PV-U	Tag, PV, and Units	Display alternating tag, Modbus PVs, and units
	OFF	Off	Display is turned off during normal operation
PV	UNITS	Units	Display units
	TAG	Tag	Display tag
	TAG-U	Tag and Units	Display alternating tag and units
	OFF	Off	Display is turned off during normal operation
PV-U	TAG	Tag	Display tag
	PV	PV	Display Modbus PVs
	TAG-PV	Tag and PV	Display alternating tag and Modbus PVs
	TG-PV-U	Tag, PV, and Units	Display alternating tag, Modbus PVs, and units
	OFF	Off	Display is turned off during normal operation
TAG-PV	UNITS	Units	Display units
	PV	PV	Display Modbus PVs
	TAG-PV	Tag and PV	Display alternating tag and Modbus PVs
	TG-PV-U	Tag, PV, and Units	Display alternating tag, Modbus PVs, and units
	OFF	Off	Display is turned off during normal operation
TG-PV-U	PV	PV	Display Modbus PVs
	TAG-PV	Tag and PV	Display alternating tag and Modbus PVs
	TG-PV-U	Tag, PV, and Units	Display alternating tag, Modbus PVs, and units
	OFF	Off	Display is turned off during normal operation

Note: Some top display selections may not appear if no PV is assigned to display on the top display.

PV Display Setup (PV SETUP)

The *PV Display Setup* menu is used to configure the display options for each Modbus PV setup in the *PV Number Configuration (PV NUM)* menu on page 31. For each Modbus PV, this includes selecting the top or bottom display, entering tag and unit, setting the Float data type decimal location (for Float data types only), setting the display decimal point location, and scaling the Modbus PV to display as engineering units.

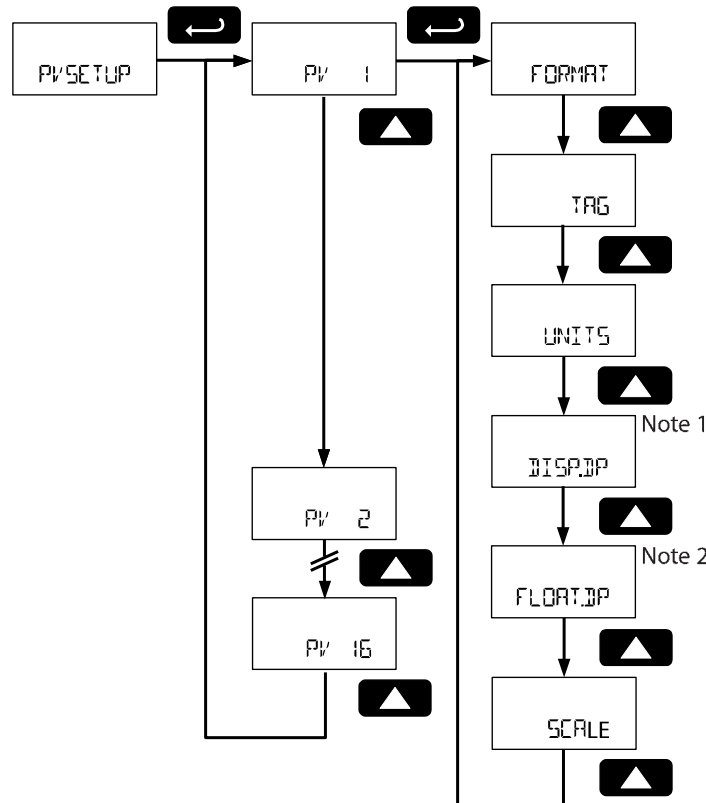

Note 1: Not applicable to feet and inches display models.

Note 2: The Float Decimal Point menu only appears if the PV data type has been set to Float (Not applicable to Ft & In model).

Modbus PV Display Format (FORMAT)

The *PV Display Setup* menu is used to configure the display options for each Modbus PV.

Decimal Display Models

The PV may appear on the top display (TOPDISP) or bottom display (BOTDISP). The PV may also be turned off (OFF) and will not display; though it may be used in math functions, and the data will be polled if in Modbus Master mode.

Feet and Inches Display Models

The PV may appear on the top feet and inches display with 1/16 of an inch (FLIN16), 1/8 of an inch (FLIN8), or appear on the 7-digit bottom display (FEEL) with no decimal points. The PV may also be turned off (OFF) and will not display; though it may be used in math functions, and the data will be polled if in Modbus Master mode.

Press **Enter** to access the *Format* menu and **Up** button to scroll through choices. Press **Enter** to make a selection and proceed to the next menu.

Press the **Menu** button to back out of a menu or hold the **Menu** button to exit at any time.

Enter Modbus PV Tag (TAG)

Each Modbus PV may have a unique programmable tag to identify the PV while the display is scanning. To program the Modbus PV tag, select the *Tag* menu and press **Enter**.

Program the custom tag as described in Setting Alphanumeric Labels on page 24. When the label has been programmed, press **Enter** to confirm the label and leave the *Tag* parameter.

Press the **Menu** button to back out of a menu or hold the **Menu** button to exit at any time.

Enter Modbus PV Units (UNITS)

Each Modbus PV may have a unique engineering unit identifier to display while scanning. To program the Modbus PV unit, select the *Units* menu and press **Enter**.

Program the custom unit as described in Setting Alphanumeric Labels on page 24. When the label has been programmed, press **Enter** to confirm the label and leave the *Units* parameter.

Press the **Menu** button to back out of a menu or hold the **Menu** button to exit at any time.

Set Float Data Type Decimal Point (FLOAT.DP)

This menu is only used if the PV selected was set to a data type of Float in PV Number Configuration (PV NUM) on page 31. To program the Modbus PV float decimal point location, select the *Float Decimal Point menu* and press **Enter**.

Set the decimal point location to correspond to the decimal point location of the float data. Pressing the **Right** arrow moves the decimal point one place to the right (including no decimal point). Pressing the **Up** arrow moves the decimal point one place to the left. Press **Enter** to confirm the number of decimal points and continue programming.

Set Display Decimal Point (DISP.DP)

Select the display decimal point location for the scaled Modbus PV value.

Decimal Display Models

Select the display decimal point location for the scaled Modbus PV value.

To program the Modbus PV, display decimal point location, select the *Display Decimal Point menu* and press **Enter**.

Pressing the **Right** arrow moves the decimal point one place to the right (including no decimal point). Pressing the **Up** arrow moves the decimal point one place to the left. Press **Enter** to confirm the number of decimal points and continue programming.

Feet and Inches Display Models

On feet and inches display models, this value is fixed, the top display PVs showing feet and inches and the bottom display PVs showing no decimal location.

Scale Modbus PV to Engineering Units (SCALE)

The Modbus PVs may be scaled to reflect different engineering units than the data read out of the Modbus slave device register. To do this, use the *Scale* menu to select the type of scale desired.

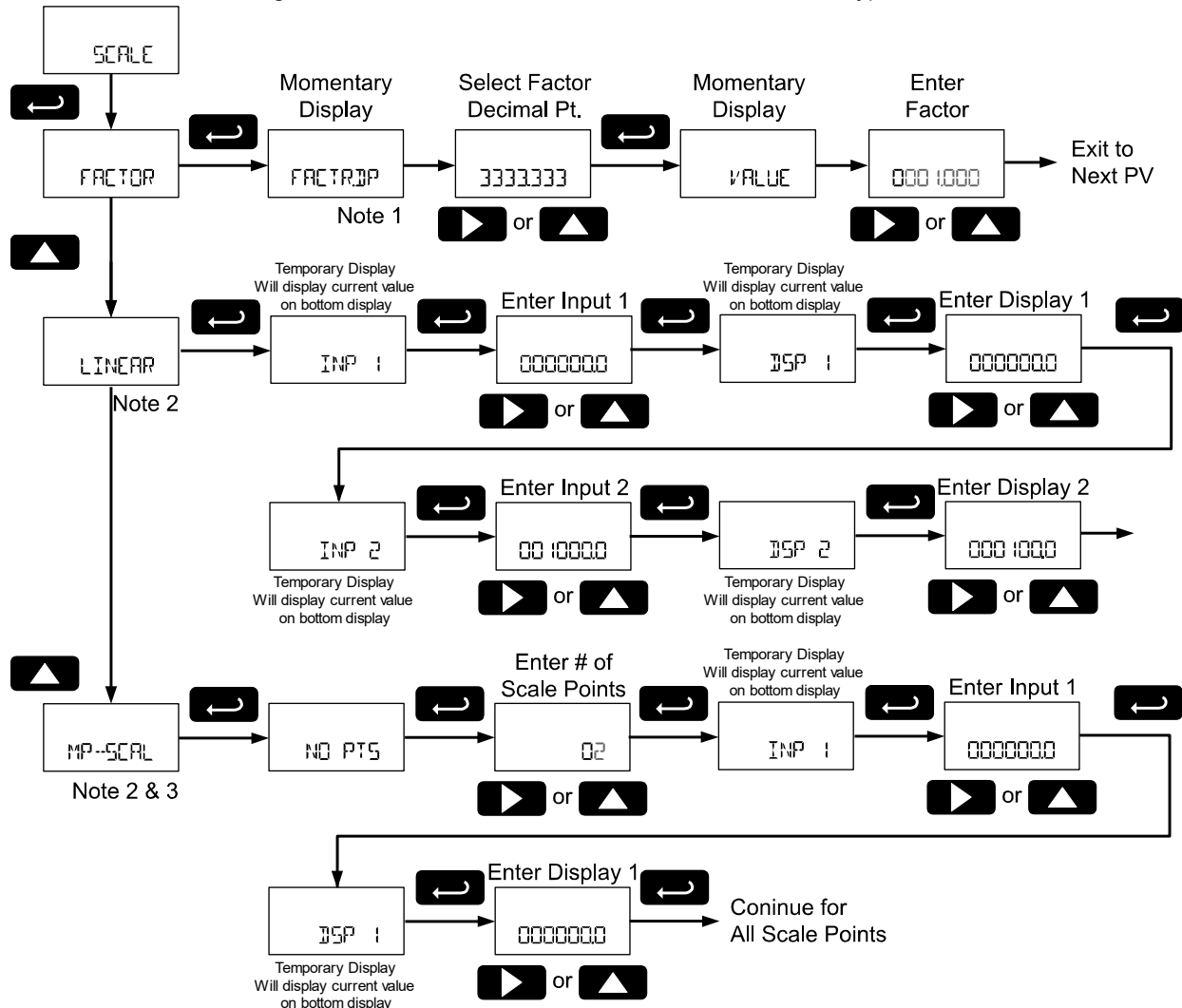

Note 1: The bottom display of the feet and inches display models does not show decimal points. While the decimal point may not appear, it is included on the factor programming steps. For example: To enter a conversion factor of 2.54, select a factor decimal point with 2 decimal locations, and enter a factor value of 254.

Note 2: MP--SCALE is only available when scaling PV1.

Factor (FACTOR)

Factor scaling uses a conversion factor for scaling a number of PV register counts to a single display count. In other words, the factor acts as a multiplier to change Modbus PV register data units into display engineering units.

Factor Decimal Point (FACTR.DP)

Enter the number of decimal point locations necessary to enter the conversion factor.

Conversion Factor Value (VALUE)

Enter the conversion factor; the multiplier value that is applied to the Modbus PV register data to convert it to the desired display engineering units.

For example: if the PV register data is a height in centimeters, but a height in inches is desired on the display, a factor of 0.393701 would be entered.

(Display Value) = (Modbus Register Value) * (Factor)

Example: (386.08 cm) * (0.393701) = (152.00 in) = (12 ft 8 in)

Note: The bottom display of the feet and inches display models does not show decimal points. While the decimal point may not appear, it is included on the factor programming steps.

For example: if the PV register data is 0 to 100 in a flowmeter, but a flow rate desired on the display is 0 to 250 GPM, a factor of 2.5 would be entered. On feet and inches display models, there is no lower display decimal point. Therefore, a factor decimal point of 1 place is selected, and a conversion factor value of 25 is entered.

Linear (LINEAR)

Linear scaling is used to convert a linear scale of PV to display value.

Input Values 1 and 2 (INP)

Enter the Modbus PV register data for scaling points 1 and 2.

Display Values 1 and 2 (DSP)

Enter the corresponding display values for input points 1 and 2.

For example: If a PV register contains data in terms of tank height in feet for a 100 feet tank, the display value can be linearly scaled for an input of 0 feet (Input 1) displaying 0 percent (Display 1), and an input of 100 feet (Input 2) displaying as 100 percent (Display 2).

Not available on Modbus PVs assigned to the feet and inches display of feet and inches display models.

Multipoint Scaling (MP--SCAL)

This type of scaling is only available for PV1. Multipoint Scaling is used when multiple linear scaling points are required, such as round horizontal tanks or conical storage silos. Up to 32 linearization points may be entered, with linear scaling between each point.

Not available on Modbus PV1 if assigned to the feet and inches display of feet and inches display model.

Number of Points (NO PTS)

Enter number of linearization points. The default value is 2 points. For linear inputs requiring only 2 scale points, use *Linear* scaling.

Math Channel Display Setup (MATH)

The *Math Channel Display Setup* menu is used to configure the display options for each of the four math channels, CV1 to CV4.

Menu will only display the math channels that have been enabled. See *Math Channel (CV1 to CV4) Programming (MATH)* on page 66 for details on programming the math functions.

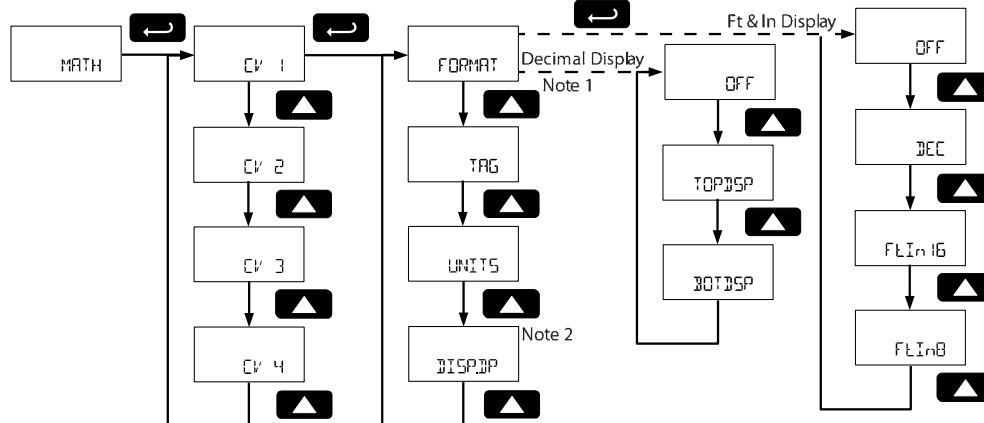

Note 1: FORMAT must be set to either TOPDISP or BOTDISP for the TAG, UNITS, and DISPLAY menus to be visible. If FORMAT is set to OFF, these menus are not visible.

Note 2: Menu not applicable to feet and inches display format.

Math Display Format (FORMAT)

The *Math Display Format* menu is used to configure the display format for each math channel. The Math Display Format must be set to display on either the top or bottom display for the TAG, UNITS and DISPLAY menus to appear.

Decimal Display Models

The math channel value may appear on the top display (TOPDISP) or bottom display (BOTDISP). The math channel value may also be turned off (OFF) and will not display; though it may be used in other math functions.

Feet and Inches Display Models

The math channel may appear on the top feet and inches display with 1/16 of an inch (FTIN16), 1/8 of an inch (FTIN8), or appear on the 7-digit bottom display (DEC) with no decimal points. The math channel may also be turned off (OFF) and will not display; though it may be used in other math functions.

Press **Enter** to access the *Format* menu and **Up** button to scroll through choices. Press **Enter** to make a selection and proceed to the next menu.

Press the **Menu** button to back out of a menu or hold the **Menu** button to exit at any time.

Enter Math Channel Tag (TAG)

Each math channel may have a unique programmable tag to identify the math channel while the display is scanning. To program the tag, select the *Tag* menu and press **Enter**.

Program the custom tag as described in *Setting Alphanumeric Labels* on page 24. When the label has been programmed, press **Enter** to confirm the label and leave the *Tag* parameter.

Press the **Menu** button to back out of a menu or hold the **Menu** button to exit at any time.

Enter Math Channel Units (UNITS)

Each math channel may have a unique engineering unit identifier to display while scanning. To program the units, select the *Units* menu and press **Enter**.

Program the custom unit as described in *Setting Alphanumeric Labels* on page 24. When the label has been programmed, press **Enter** to confirm the label and leave the *Units* parameter.

Press the **Menu** button to back out of a menu or hold the **Menu** button to exit at any time.

Set Display Decimal Point (DISP)

Select the display decimal point location for the math channel value. To program the math channel display decimal point location, select the *Display Decimal Point menu* and press **Enter**.

Decimal Display Models

Set the display decimal point location for the math channel. Pressing the **Right** arrow moves the decimal point one place to the right (including no decimal point). Pressing the **Up** arrow moves the decimal point one place to the left. Press **Enter** to confirm the number of decimal points and continue programming.

Feet and Inches Display Models

Feet and inches display models do not have this menu. On feet and inches display models, this value is fixed, the top display PVs showing feet and inches and the bottom display PVs showing no decimal location.

Pulse Rate Display Setup (RATE)

The *Rate Display Setup* menu configures the pulse input rate display. For information on setting up the pulse input, refer to Setting Pulse Input Type (PULSE.IN) on page 52.

This menu is used to configure:

- Rate Display Format (Top Display, Bottom Display, or Off)
- Rate Tag
- Rate Time Base
- Rate Units
- Rate Display Decimal Point

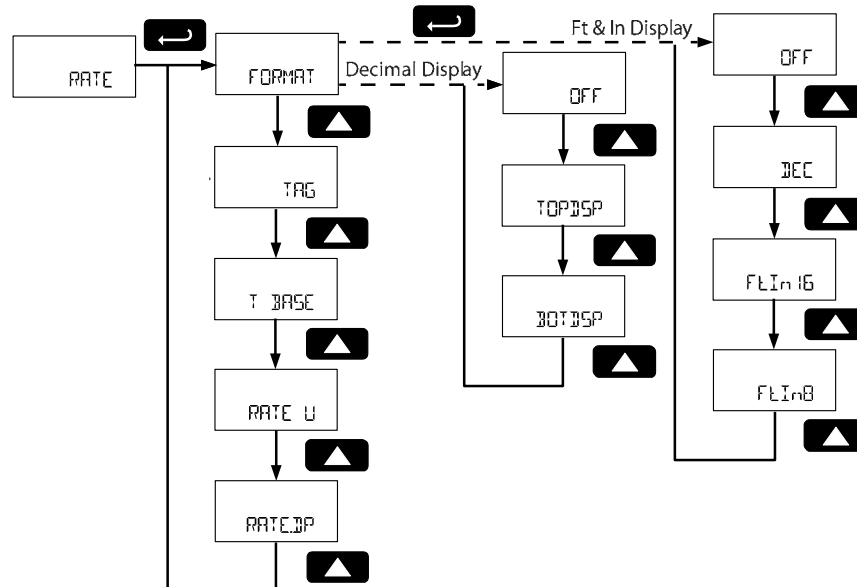

Note 1: Menu selection is not present in feet and inches display models.

Rate Display Format

The rate display format is selected after pressing **Enter** at the *Rate Display Setup* menu (RATE). If the rate is set to off (OFF), then no other rate parameters are configured. Otherwise, the rate display will be cycled on the display with the Modbus PVs.

On decimal display models, the rate may appear on the top display (TOPDSP) or bottom display (BOTDSP).

On feet and inches display models, the rate may appear only on the bottom display (BOTDSP) with no decimal points.

Enter Rate Tag (TAG)

The rate display may include a custom tag to identify it while the display is scanning. To program the tag, select the *Tag* menu and press **Enter**.

Program the custom tag as described in Setting Alphanumeric Labels on page 24. When the label has been programmed, press **Enter** to confirm the label and leave the *Tag* parameter.

Press the **Menu** button to back out of a menu or hold the **Menu** button to exit at any time.

Select Rate Time Base (T BASE)

The scanner calculates pulse input rate based on rate time base and the rate display units. The time base is the unit of time used to calculate the rate, and can be set as units per second, minute, hour, or day.

Press **Enter** to access the *Time Base* menu and **Up** button to scroll through choices. Press **Enter** to make a selection and proceed to the next menu.

Press the **Enter** button, at any time, to accept a setting or **Menu** button to exit without saving changes.

Select Rate Display Units (RATE U)

Rate is displayed in terms of a unit of volume, and a time base. The unit selected will be used with the time base to establish the rate unit (example: GAL/M when *Units* is gallons and time base is seconds).

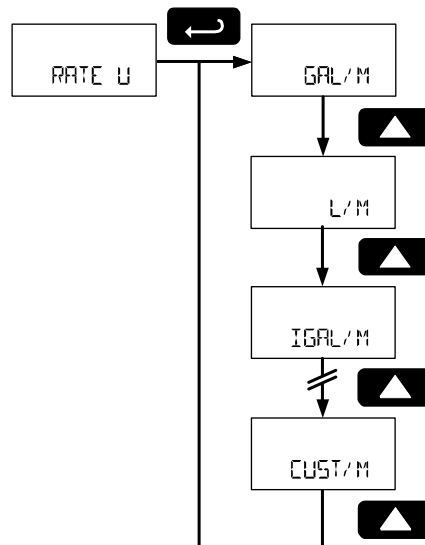

Press **Enter** to access the *Rate Units* menu and **Up** button to scroll through choices. Press **Enter** to make a selection and proceed to the next menu. Press the **Menu** button to exit without saving changes.

The following units may be selected as the base units for rate. The time base for rate is selected separately in other menus.

Rate Unit Selection	Unit	Description
GAL/M*	Gallon/ Minute *	Gallons per time base unit
L/M*	Liter/ Minute *	Liters per time base unit
IGAL/M*	Imperial Gallon/ Minute *	Imperial Gallons per time base unit
M ³ /M*	Meters ³ / Minute *	Meters cubed per time base unit
BBL/M*	Barrel/ Minute *	Barrel per time base unit
BUSH/M*	Bushels/ Minute *	Bushels per time base unit
CUYD/M*	Cubic Yards/ Minute *	Cubic yards per time base unit
CUFL/M*	Cubic Feet/ Minute *	Gallons per time base unit
CUIN/M*	Cubic Inches/ Minute *	Gallons per time base unit
LBBL/M*	Liquid Barrels/ Minute *	Gallons per time base unit
BBBL/M*	Beer Barrels/ Minute *	Gallons per time base unit
HECLL/M*	Hectoliters/ Minute *	Gallons per time base unit
CUST/M*	Custom Volume/Minute*	Custom volume/hour (enter custom rate conversion factor)

* Rate time base shows as minute for example only. See Select Rate Time Base (T BASE) on page 44 for details on setting the appropriate base time unit for your application.



IMPORTANT

The units selected in this menu are the desired display units only. The units defined by the k-factor of a flow meter are entered in the K-Factor menu as part of the Factor Unit menu programming. See K-Factor Units (F UNIT) on page 54 for details.

This allows the display units to be different than the units defined by the flow meter or be changed easily after initial programming. Unit conversions for rates and totals are performed automatically by the scanner. See Automatic Unit Conversions on page 50 for details.

The custom rate unit selection (CUSTOM) will require the custom unit to be entered by the user. See Custom Units Entry (CUSTOM) on page 50.

Set Rate Display Decimal Point (RATE.DP)

The *Rate Display Decimal Point* menu sets the number of decimal points in the rate display. Press **Enter** to access the *Rate Display Decimal Point* menu.

Decimal Display Models

Set the display decimal point location for the rate display. Pressing the **Right** arrow moves the decimal point one place to the right (including no decimal point). Pressing the **Up** arrow moves the decimal point one place to the left. Press **Enter** to confirm the number of decimal points and continue programming.

Feet and Inches Display Models

Feet and inches display models do not have this menu. On feet and inches display models, the rate appears on the bottom display only, with no decimal locations.

Pulse Totalizer Display Setup (TOTAL)

The *Total Display Setup* menu configures the pulse input totalizer. For information on setting up the pulse input, refer to Setting Pulse Input Type (PULSE.IN) on page 52.

This menu is used to configure:

Total Display Format (Top Display, Bottom Display, or Off)

Total Units

Total Display Decimal Point

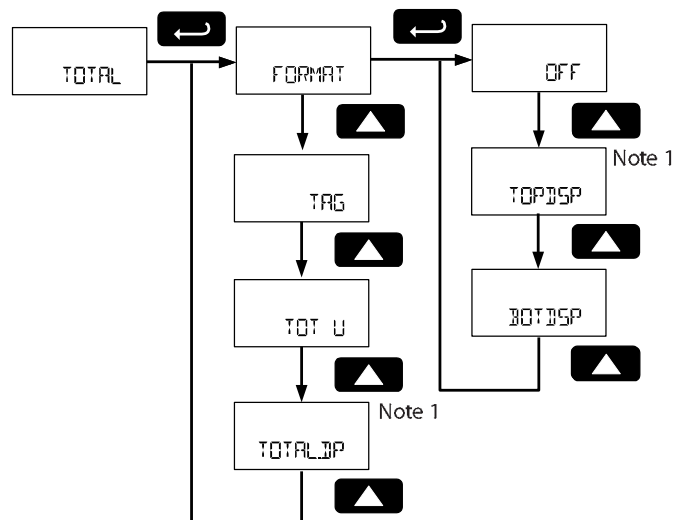

Note 1: Menu selection is not present in feet and inches display models.

Total Display Format

The total display format is selected after pressing **Enter** at the *Total Display Setup* menu (TOTAL). If the total is set to off (OFF), then no other total parameters are configured. Otherwise, the total display will be cycled on the display with the Modbus PVs.

On decimal display models, the total may appear on the top display (TOP.DSP) or bottom display (BOT.DSP).

On feet and inches display models, the total may appear only on the bottom display (BOT.DSP) with no decimal points.

Tag (TAG)

The total display may have a unique programmable tag to identify it while the display is scanning. To program the total display tag, select the *Tag* menu and press **Enter**.

Program the custom tag as described in Setting Alphanumeric Labels on page 24. When the label has been programmed, press **Enter** to confirm the label and leave the *Tag* parameter.

Press the **Menu** button to back out of a menu or hold the **Menu** button to exit at any time.

Total Units (TOT U)

This menu is used to select the display units for the total.

Total is displayed as a unit of volume with a multiplier. The multiplier prefix will appear before the total unit (examples: MGAL, KL).

A base unit and a multiplier prefix are selected. If total and units are selected to display, the multiplier prefix will appear before the total unit (examples: MGAL, KL).

Multipliers will convert the total for 1, 100, 1000, or 1 million units. The scanner will appropriately calculate the total for display with the programmed multiplier and units.

A custom unit may be selected (VOL CUST), and no multiplier menu will be required. See Custom Units Entry (CUST) on page 50.

Press Enter to access the Total Units menu and Up button to scroll through choices. Press Enter to make a selection and proceed to the next menu. If a unit other than custom unit (VOL CUST) was selected, select a total unit multiplier. Press the Up button to scroll through multiplier choices, and press Enter to make a selection and continue programming.

The custom total unit selection (VOL CUST) will require the custom unit to be entered by the user. See Custom Units Entry (CUST) on page 50. A total conversion factor is available with custom units.

Press the Menu button to exit without saving changes.

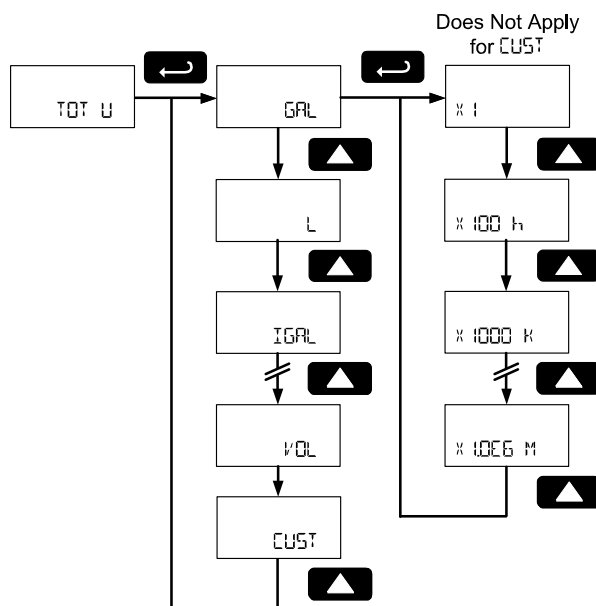

The following units may be selected as the base units for total and grand total.

Total Unit Selection	Unit	Description
GAL	Gallons	Gallons
L	Liters	Liters
IGAL	Imperial Gallons	Imperial gallons
M3	Meters ³	Meters cubed
BDL	Barrels	Barrels
BUSH	Bushels	Bushels
CUYD	Cubic Yards	Cubic yards
CUFE	Cubic Feet	Cubic feet
CUIN	Cubic Inches	Cubic inches
LBDL	Liquid Barrels	Liquid barrels
BBBL	Beer Barrels	Beer barrels
HECLL	Hectoliters	Hectoliters
CUST	Custom Volume	Enter custom total or grand total unit

Set Total Display Decimal Point (TOTALDP)

The *Total Display Decimal Point* menu sets the number of decimal points in the total display. Press **Enter** to access the *Total Display Decimal Point* menu.

Decimal Display Models

Set the display decimal point location for the total display. Pressing the **Right** arrow moves the decimal point one place to the right (including no decimal point). Pressing the **Up** arrow moves the decimal point one place to the left. Press **Enter** to confirm the number of decimal points and continue programming.

Feet and Inches Display Models

Feet and inches display models do not have this menu. On feet and inches display models, the total appears on the bottom display only, with no decimal locations.

Grand Totalizer Display Setup (Gr TOTAL)

The *Grand Total Display Setup* menu configures the pulse input grand totalizer. For information on setting up the pulse input, refer to Setting Pulse Input Type (PULSE.IN) on page 52.

This menu is used to configure:

- Grand Total Display Format (Top Display, Bottom Display, or Off)
- Grand Total Units
- Grand Total Display Decimal Point

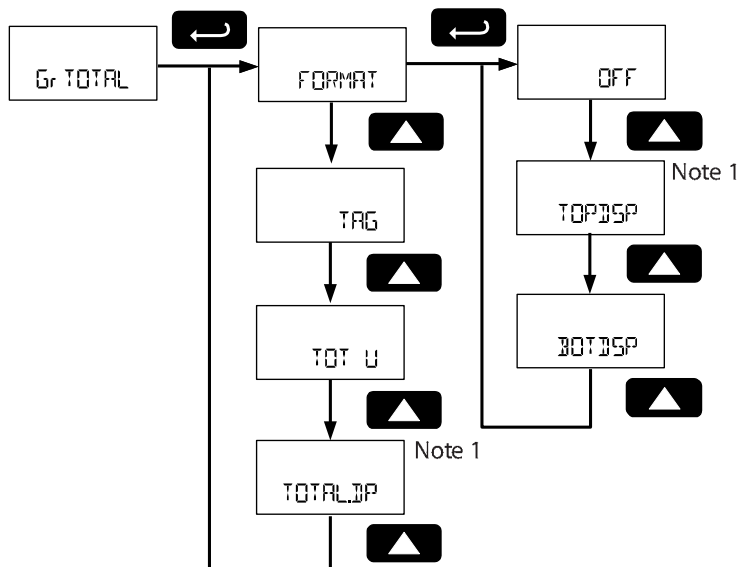

Note 1: Menu selection is not present in feet and inches display models.

Grand Total Display Format

The grand total display format is selected after pressing **Enter** at the *Grand Total Display Setup* menu (**Gr TOTAL**). If the total is set to off (**OFF**), then no other total parameters are configured. Otherwise, the grand total display will be cycled on the display with the Modbus PVs.

On decimal display models, the grand total may appear on the top display (**TOPDISP**) or bottom display (**BOTDISP**).

On feet and inches display models, the grand total may appear only on the bottom display (**BOTDISP**) with no decimal points.

Grand Total Units (GTOT U)

This menu is used to select the display units for the grand total.

Grand total is displayed as a unit of volume with a multiplier. The multiplier prefix will appear before the total unit (examples: MGAL, KL).

A base unit and a multiplier prefix are selected. If total and units are selected to display, the multiplier prefix will appear before the total unit (examples: MGAL, KL).

Multipliers will convert the grand total for 1, 100, 1000, or 1 million units. The scanner will appropriately calculate the grand total for display with the programmed multiplier and units.

A custom unit may be selected (VOL CUST), and no multiplier menu will be required. See Custom Units Entry (CUST) on page 50.

Press **Enter** to access the *Grand Total Units* menu and **Up** button to scroll through choices. Press **Enter** to make a selection and proceed to the next menu. If a unit other than custom unit (VOL CUST) was selected, select a grand total unit multiplier. Press the **Up** button to scroll through multiplier choices, and press **Enter** to make a selection and continue programming.

The custom grand total unit selection (VOL CUST) will require the custom unit to be entered by the user. See Custom Units Entry (CUST) on page 50.

Press the **Menu** button to exit without saving changes.

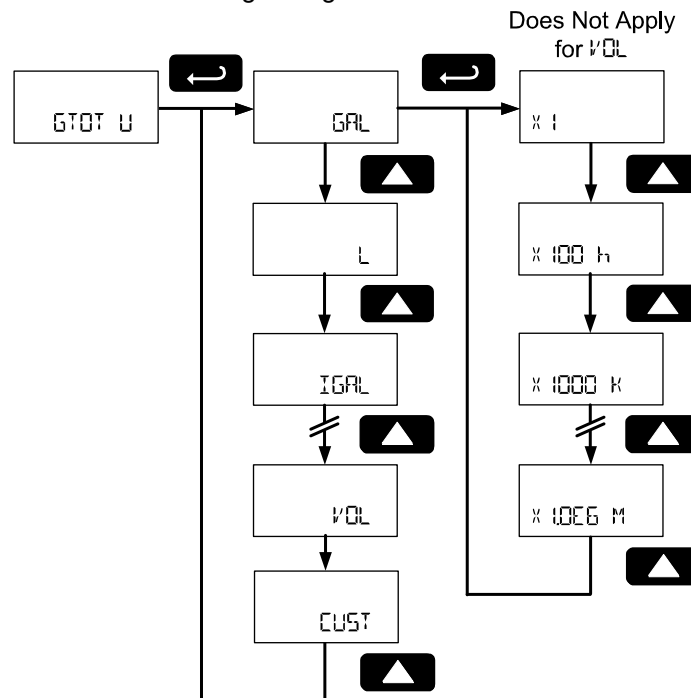

Refer to the Total Units Selection table on page 47 for a list of available grand total units.

Set Grand Total Display Decimal Point (GRTOTDP)

The *Grand Total Display Decimal Point* menu sets the number of decimal points in the grand total display. Press **Enter** to access the *Grand Total Display Decimal Point* menu.

Decimal Display Models

Set the display decimal point location for the grand total display. Pressing the **Right** arrow moves the decimal point one place to the right (including no decimal point). Pressing the **Up** arrow moves the decimal point one place to the left. Press **Enter** to confirm the number of decimal points and continue programming.

Feet and Inches Display Models

Feet and inches display models do not have this menu. On feet and inches display models, the grand total appears on the bottom display only, with no decimal locations.

Automatic Unit Conversions

When switching from any standard unit of rate, total, or grand total to any other standard unit, automatic unit conversions are performed by the scanner.

No unit conversions will be performed when the K-Factor Units (*F-Units*) menu is set to custom (CUSTOM).

A total or grand total unit conversion will automatically change the displayed total and grand total to the equivalent volume of the newly selected unit.

Custom Units Entry (CUSTOM)

When a custom unit is selected for rate, total, or grand total, a menu allows for entry of the custom unit.

Any 5-digit 14-segment unit label may be entered for a custom rate unit (example: DRUMS).

Any 7-digit 14-segment unit label may be entered for a custom total or grand total unit (examples: BOTTLES, DRUMS). A custom rate, total, or grand total unit will allow a total or grand total conversion factor to be entered to define the unit. When selected for total or grand total, a custom unit will not allow a multiplier prefix.

Custom Rate, Total, and Grand Total Units Name (CUNITS, TUNITS, GTUNIT)

If a custom rate unit has been selected (CUSTOM) for rate, total, or grand total, an indicator (CUNITS, TUNITS, or GTUNIT respectively) will display for one second, followed by the custom unit name.

Note: VOL is the default custom unit name for rate. TOTAL is the default custom unit name for total.

Gr TOTAL is the default custom unit name for grand total.

To change the name of the custom unit, press **Enter** when the custom unit name is being displayed and enter the new custom unit name. For details on setting the custom unit name, refer to Setting Alphanumeric Labels on page 24. Press **Menu** button to exit this menu without saving changes.

Custom Units Conversion Factor (RATE-CF, TOT-CF, GT-CF)

After the custom unit name has been entered, enter the rate, total, or grand total conversion factor. The conversion factor is the number used to multiply from the desired custom units to the units chosen to define the k-factor. For example, if the rate unit conversion factor is to display rate in bottles/second, and each bottle holds 2.5 gallons, the conversion factor is 0.4 (bottles/gallon) if the k-factor was entered in pulses/gallon. Use the **Up** or **Right** arrows to select the number of decimal points needed for the conversion factor. Press **Enter**. After the conversion factor label is displayed (RATE-CF, TOT-CF, GT-CF), enter the conversion factor. Press the **Enter** button, at any time, to accept a setting or **Menu** button to exit without saving changes. The following example details setting a custom rate conversion factor.

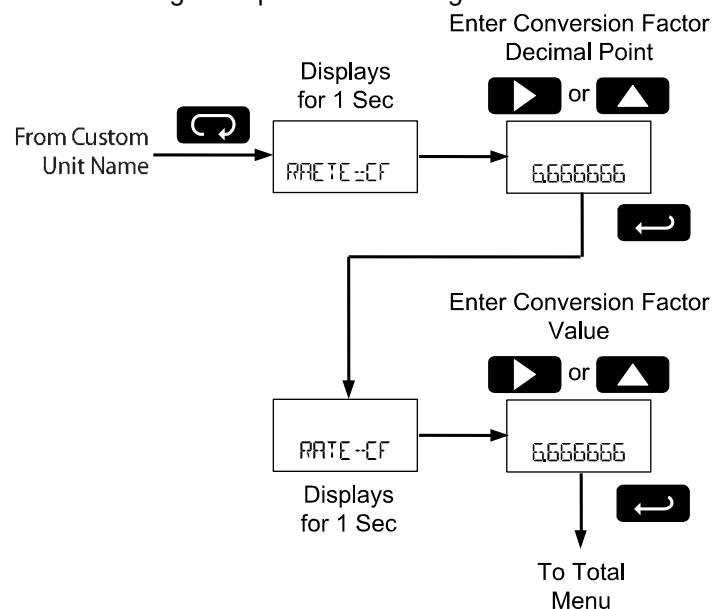

See Setting Numeric Values on page 24 for more information on programming the rate, total, or grand total conversion factor.

Tank Indicator Tank Size (TANKSZ)

The *Tank Size* menu defines the 100% full level for the 20-segment tank level indicator on feet and inches display models. This menu is not present in decimal display models. All PV values displayed on the top line feet and inches display will use this tank level indicator.

To set the maximum height of the tank level indicator, enter the level for thank to display as full. Enter the full value in feet.

See Setting Numeric Values on page 24 for more information on entering the tank full level in feet.

Press **Enter** to confirm and save the tank level indicator full value.

Tag Display Time (T--TAG)

If either display is set to toggle a custom tag as part of the *Top Display* or *Bottom Display* programming the scanner will prompt for a toggle time with this menu.

The custom tag for each variable will display before each variable for a number of seconds set by this parameter. The tag may be programmed to display for 1 to 49 seconds.

Press **Enter** to access the *Tag Display Time* menu. Use the **Up** and **Right** buttons enter the tag display time. Press **Enter** to make a selection and proceed to the next menu. See Setting Numeric Values on page 24 for more information.

Press the **Menu** button to exit without saving changes.

Units Display Time (T--UNITS)

If either display is set to toggle units as part of the *Top Display* or *Bottom Display* programming the scanner will prompt for a toggle time with this menu.

The unit for each variable will display before each variable for a number of seconds set by this parameter. The unit may be programmed to display for 1 to 49 seconds.

Press **Enter** to access the *Units Display Time* menu. Use the **Up** and **Right** buttons enter the units display time. Press **Enter** to make a selection and proceed to the next menu. See Setting Numeric Values on page 24 for more information.

Press the **Menu** button to exit without saving changes.

Scan Time (T--SCAN)

The scan time defines how long a variable will be shown on the display while automatically scanning. After the scan time has elapsed, the next tag, unit, and variable will be displayed.

The scan time may be programmed to cycle the display to the next variable every 2 to 99 seconds.

Press **Enter** to access the *Scan Time* menu. Use the **Up** and **Right** buttons enter the scan time. Press **Enter** to make a selection and proceed to the next menu. See Setting Numeric Values on page 24 for more information.

Press the **Menu** button to exit without saving changes.

Setting Pulse Input Type (PULSE.IN)

Seven input types may be set for the pulse input, and it may be disabled. See Pulse Input specifications on page 11.

The pulse input is disabled with factory settings.

Press **Enter** to access the menu then press the **Up** to scroll through the flashing choices. Press Enter to accept the setting. Press **Menu** to back out of a menu or hold **Menu** to exit at any time.

The following input types may be selected.

Input Selection	Input Type	Description
ACTIVE	Active	External power supply driven pulse inputs
NPN	NPN	Internal pull-up resistor on S+ for NPN inputs
PNP	PNP	Internal pull-down resistor on S+ for PNP inputs
REED	Reed	Internal pull-up resistor on S+ for switch inputs
COIL	Coil	Magnetic coil flowmeter inputs Note: Input selector switch must be set to mV
ISO	Active, Isolated	External power supply driven isolated pulse inputs. Note: Input selector switch must be set to ISO
ACTLO	Active, Low	External power supply driven pulse inputs with a low threshold
NPNLO	NPN, Low	Internal 3 V pull-up resistor on S+ for NPN inputs with a low threshold
PNPLO	PNP, Low	Internal pull-down resistor on S+ for PNP inputs with a low threshold
DISABLE	Disable Input	Disable the pulse input and all pulse input related features including rate, total, and grand total features

Input Level Selection Switch

In addition to programming the PULSE.IN parameter, the input selector switch shown below must also be set. Input voltage level selections include mV, V and isolated voltage level inputs.

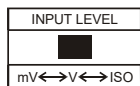

See **Pulse Input Signal Connections** on page 20 for details on wiring the input types.

Entering the K-Factor (KFACTOR)

The pulse input used for rate, total, and grand total may be scaled using the *K-factor*, or conversion factor, function. Most flowmeter manufacturers provide this information with the device. Enter the *K-Factor* (KFACTOR) menu and select the units defined with the k-factor (example: pulses/gal), the decimal point with highest resolution possible, and program the K-Factor value. The scanner will automatically calculate the flow rate, total, and grand total using the K-Factor and the units and time base selected in the *Rate*, *Total*, and *Grand Total* menus.

 IMPORTANT	<p>Performing a k-factor operation will override any scaling or calibration programming. Refer to To enter the Cutoff, see Setting Numeric Values on page 24 for more information.</p> <p>Pulse Input Scaling & Calibration (SCALECAL) on page 68 for more information on these programming methods.</p>
----------------------	--

Press **Enter** to access the menu then press the **Up** to scroll through the menu choices. Press **Enter** to select a menu and press the **UP** to scroll through the flashing choices. Press **Enter** to accept the setting. Press **Menu** to back out of a menu or hold **Menu** to exit at any time.

 IMPORTANT	<p>Performing k-factor programming will override any input scaling programming. Verify the method of programming required and use the password protection feature to secure the scanner if necessary.</p> <p>For information on the <i>Undo?</i> menu, refer to Undoing K-Factor or Scale Programming (UNDO? KFACTOR) on page 68.</p>
----------------------	--

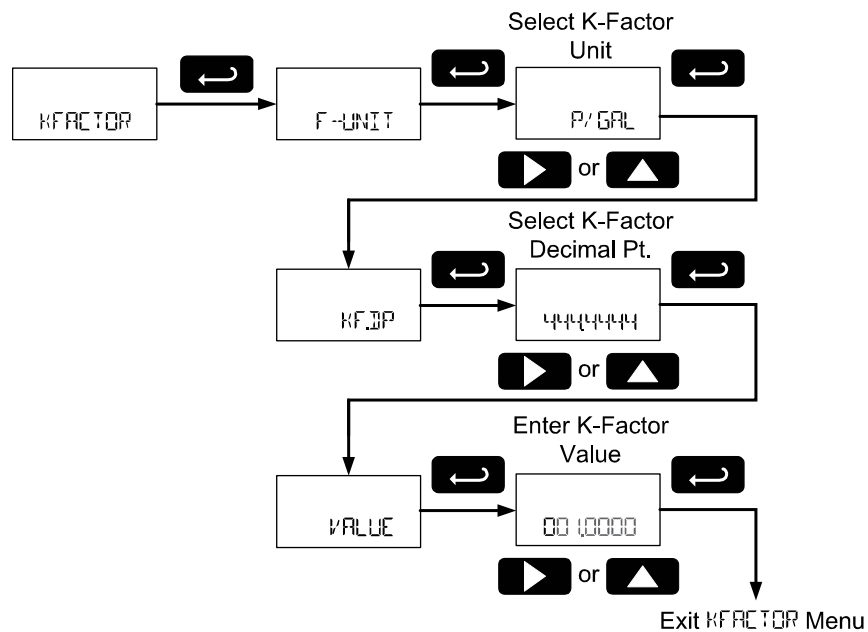

Undoing K-Factor or Scale Programming (UNDO? KFACTOR)

Whenever the input programming is being changed from using k-factor to scaling; or from scaling to k-factor, a confirmation menu appears. This prevents accidental changing of the input programming. The example below shows a meter programmed with a k-factor being reprogrammed to utilize pulse input scaling.

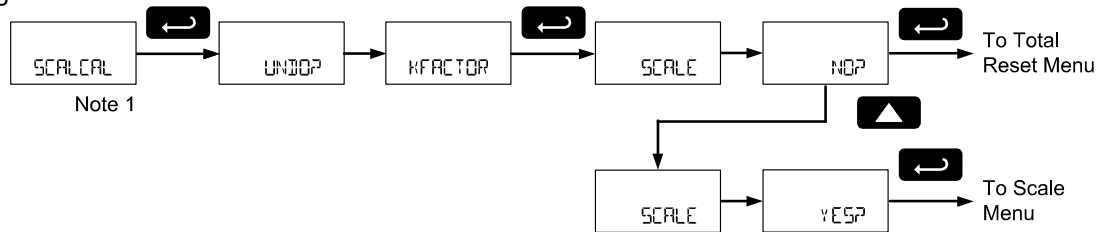

Note 1: The Undo? menu will appear after the Scaling and Calibration menu if the scanner pulse inputs are programmed with a k-factor. If a scaling operation has already been performed, the Undo? menu will appear after the K-Factor menu instead.

K-Factor Units (F-UNIT)

Select the units defined with the k-factor (example: pulses/gal). This is usually provided by the flowmeter manufacturer. This does not set the rate display units, and only relates to entering the K-factor. To set or change the rate display units, see Pulse Rate Display Setup (RATE) on page 44

The K-Factor Custom Unit (P/VOL)

Automatic unit conversions are not performed when the K-factor unit is set to custom. See page 50 for information on the automatic unit conversion feature.

K-Factor Decimal Point (KF.DP)

Set the number of decimal places necessary to enter the K-factor value. The decimal point may be set with up to six decimal places or with no decimal point at all.

Pressing **Right** moves the decimal point one place to the right (including no decimal point). Pressing **Up** moves the decimal point one place to the left.

K-Factor Value (VALUE)

Enter the K-factor value. This value is entered in Pulses/Unit as defined by the *K-Factor Units* parameter. Most flowmeter manufacturers provide this information with the device.

Serial Communications Settings (COMM)

The *Serial Communications* menu is used to setup serial communications parameters necessary for communication via the RS-485 connection and Modbus.

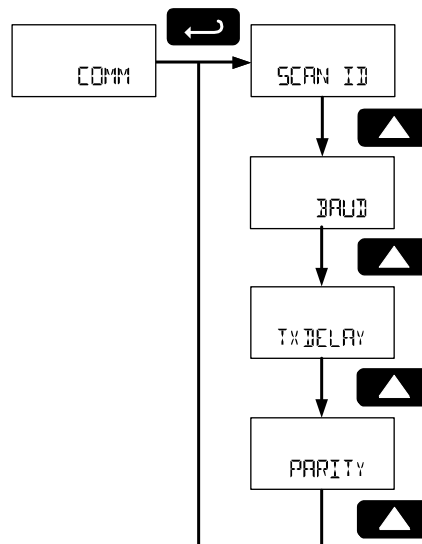

Press **Enter** to access the *Serial Communications Settings* menu then press the **Up** to scroll through the menu choices. Press **Enter** to select a menu. Press **Menu** to back out of a menu or hold **Menu** to exit at any time.

Modbus communications is performed with the 3-wire (including Ground) RS-485 connector.

Refer to the Tek-LCD 7804B Scanner Modbus Register Tables located at www.tek-trol.com for additional Modbus information.

Scanner Modbus ID (SCAN ID)

The *Scanner Modbus ID* menu sets the Modbus address (ID) of the scanner. The scanner Modbus ID may be programmed between 1 and 247. When using more than one device in a multi-drop mode, each device must be provided with its own unique address.

To program the Modbus ID, refer to Setting Numeric Values on page 24.

Baud Rate (BAUD)

The baud rate may be set to 1,200; 2,400; 4,800; 9,600; 19,200; 38,400; 57,600; or 115,200 bps.

In the *Baud Rate* menu, use the **Up** button to scroll through the menu choices. Press **Enter** to make a selection and proceed to the next menu.

Transmit Delay Time (TX DELAY)

The transmit delay may be set between 0 and 199 ms.

To program the transmit delay time, refer to Setting Numeric Values on page 24.

Parity (PARITY)

The parity can be set to even (EVEN), odd (ODD), or none with 1 (NONE 1) or 2 (NONE 2) stop bits.

In the *Baud Rate* menu, use the **Up** button to scroll through the menu choices. Press **Enter** to make a selection and proceed to the next menu.

ADVANCED MENU

Display Functions & Messages

The scanner displays various functions and messages during setup of advanced features. The following table shows the *Advanced Features* menu functions and messages in the order they appear in the menu.

Display	Parameter	Action/Setting
ADVANCE	<i>Advanced</i>	Enter <i>Advanced</i> menu
OUTPUT	<i>Output</i>	Setup open collector outputs Out 1 and Out 2
OUT 1	<i>Output 1</i>	Assign function of open collector output 1
OFF	<i>Off</i>	Disable output
PULSE	<i>Pulse</i>	Set Out 1 or Out 2 for pulse output mode
RATE	<i>Rate</i>	Assign pulse output to rate
DECP	<i>Decimal Point</i>	Set Count decimal point
COUNT	<i>Count Value</i>	Set count value
TOTAL	<i>Total</i>	Assign pulse output to total
Gr TOTAL	<i>Grand Total</i>	Assign pulse output to grand total
RETRAN	<i>Retransmit</i>	Assign pulse output to retransmit
QUAD	<i>Quadrature</i>	Assign pulse output to quadrature
TEST	<i>Test</i>	Assign pulse output to test mode
PV	<i>Process Variable</i>	Assign pulse output to a PV or CV
SOURCE	<i>Source</i>	Set pulse output reference variable
ALARM	<i>Alarm</i>	Assign Out 1 or Out 2 for alarm output mode
PV NUM	<i>Process Variable Number</i>	Assign alarm output to a PV or CV
PV 1	<i>Process Variable 1</i>	Select Process Variable to assign alarm to (1-16)
SET	<i>Set Point</i>	Set rate alarm set point
RESET	<i>Reset Point</i>	Set rate alarm reset point
RATE	<i>Rate</i>	Assign alarm output to rate
SET	<i>Set Point</i>	Set rate alarm set point
RESET	<i>Reset Point</i>	Set rate alarm reset point
TOTAL	<i>Total</i>	Assign alarm output to total
GRTOT	<i>Grand Total</i>	Assign alarm output to grand total
ON	<i>On</i>	Set output to on state
OFF	<i>Off</i>	Set output to off state
TIMER	<i>Timer</i>	Set Out 1 or Out 2 for timed pulse output mode
START	<i>Start</i>	Activate timed pulse output
PERIOD	<i>Delay</i>	Set the time of one period (seconds)
TIME	<i>On</i>	Set the active low pulse width time
OUT 2	<i>Output 2</i>	Assign function of open collector output 2
A OUT	<i>Analog Output</i>	Enter <i>Analog Output</i> menu
SOURCE	<i>Source</i>	Set analog output reference variable
PV 1	<i>Process Variable 1</i>	Set PV as analog output source, can select any active PV (1-16)
DISP 1	<i>Display 1</i>	Output display 1 value
OUT 1	<i>Output 1</i>	Output 1 value

Display	Parameter	Action/Setting
DISPLY 2	<i>Display 2</i>	Output display 2 value
OUT 2	<i>Output 2</i>	Output 2 value
SAVEP	<i>Save</i>	Save entered analog parameters
CV 1	<i>Math Channel 1</i>	Set CV as analog output source, can select any active CV (1-4)
RATE	<i>Rate Output</i>	Set rate as output variable
TOTAL	<i>Total Output</i>	Set total as output variable
Gr TOTAL	<i>Grand Total Output</i>	Set grand total as output variable
DISABLE	<i>Disable</i>	Turn off the analog output
MATH	<i>Math</i>	Enter <i>Math</i> menu
CV 1	<i>Math Channel 1</i>	Program math channel (Channel 1-4)
MULTI	<i>Multiply</i>	Set math to multiply
PAR 1	<i>Parameter 1</i>	Enter math function parameter 1
PAR2	<i>Parameter 2</i>	Enter math function parameter 2
PAR3	<i>Parameter 3</i>	Enter math function parameter 3
L2P 1	<i>Level 2 Parameter 1</i>	Enter nested math function level 2 parameter 1
L2P2	<i>Level 2 Parameter 2</i>	Enter nested math function level 2 parameter 2
L2P3	<i>Level 3 Parameter 3</i>	Enter nested math function level 2 parameter 3
DIVIDE	<i>Divide</i>	Set math function to divide
DIFFABS	<i>Absolute Difference</i>	Set math function to absolute difference
WAVG	<i>Weighted Average</i>	Set math function to weighted average
DRAW	<i>Draw</i>	Set math function to draw
RATIO	<i>Ratio</i>	Set math function to ratio
CONCEN	<i>Concentration</i>	Set math function to concentration
CONST	<i>Constant</i>	Set math function to a constant value
NONE	<i>None</i>	Set math function to none
ABS	<i>Absolute Value</i>	Set math function to absolute value
SQRT	<i>Square Root</i>	Set math function to square root
SUM	<i>Sum</i>	Set math function to sum
DIFF	<i>Difference</i>	Set math function to difference
GATE	<i>Gate</i>	Enter <i>Gate</i> menu
LO GATE	<i>Low Gate</i>	Set <i>Low Gate</i>
HI GATE	<i>High Gate</i>	Set <i>High Gate</i>
FILTER	<i>Filter</i>	Enter <i>Filter</i> menu
HI	<i>High Speed Filter</i>	Set <i>high speed</i> filter
LO	<i>Low Speed Filter</i>	Set <i>low speed</i> filter
MED	<i>Medium Speed Filter</i>	Set <i>medium speed</i> filter
CUTOFF	<i>Low-Flow Cutoff</i>	Enter <i>Low-Low Cutoff</i> menu
SCALECAL	<i>Scale & Calibrate</i>	Enter the <i>Scale & Calibrate</i> menu to program without using a k-factor
UNDOP KFACTOR	<i>Undo K-Factor</i>	Undo the k-factor programming and use <i>Scale</i> menu programming? (This option will only appear if meter is currently set for K-Factor)
SCALE NOP	<i>Scale No?</i>	Do not use scale programming
SCALE YESP	<i>Scale Yes?</i>	Use scale programming
NO PTS	<i>Number of Points</i>	Enter the number of scaling or calibration points

Display	Parameter	Action/Setting
UNIS	Scale Volume Units	Enter pulse input scaled volume units
T BASE	Scale Time Unit	Enter the pulse input scaled rate time unit
INP 1	Input 1	Calibrate or scale input 1 value
ISP 1	Display 1	Program display 1 value
INP 2	Input 2	Calibrate or scale input 2 value
ISP 2	Display 2	Program display 2 value
SAVEP	Save	Save entered calibration or scale parameters
T RESET	Total Reset	Enter the Total Reset menu
TOTAL	Total Reset	Select the Total Reset method
MAN	Manual	Manual total reset
ENABLE	Enable	Enable manual reset
DISABLE	Disable	Disable manual reset
AUTO	Automatic	Automatic total reset
T DELAY	Time Delay	Automatic reset time delay
GTRESET	Grand Total Reset	Select the Grand Total Reset method
PASSWORD	Password	Enter the Password menu
UNLOCKED	Unlocked	Program password to lock scanner
LOCKED	Locked	Enter password to unlock scanner
PASS	Password	Program password to lock scanner parameters
UNLOC	Unlock	Password has been unlocked
LOCK	Lock	Password has been locked
PASS T	Password Total	Program password to prevent total reset
PASS GT	Password Grand Total	Enter password to lock out grand total related parameters and reset
CUSTOM	Custom	Enter Custom menu
POS 1	Position 1	Set menu position 1 (1-8)
SYSTEM	System	Enter System menu
SETTIME	Set Time	Set real-time clock date and time
YEAR	Year	Set the year
MONTH	Month	Set the month
01	January	Set month as January
02	February	Set month as February
03	March	Set month as March
04	April	Set month as April
05	May	Set month as May
06	June	Set month as June
07	July	Set month as July
08	August	Set month as August
09	September	Set month as September
10	October	Set month as October
11	November	Set month as November
12	December	Set month as December
DAY	Day	Set the day

Display	Parameter	Action/Setting
TIME	<i>Time</i>	Set the hour and minute
DATALOG	<i>Data Log</i>	Enter <i>Data Log</i> menu
LOGTIME	<i>Log Time</i>	Set daily data log times
LOG 1	<i>Log 1</i>	Set first daily log time (1-4)
DISABLE	<i>Disable</i>	Disable log number
ENABLE	<i>Enable</i>	Enable log number
INTERVL	<i>Interval</i>	Set interval log time
FULSTOP	<i>Stop When Full</i>	Data logging will stop when the log is full
CONT	<i>Continue</i>	Data logging will continue when the log is full, deleting old data
START	<i>Start</i>	Begin interval logging
LOGVIEW	<i>Log View</i>	View data log
LOGVIEW ALL	<i>All Log View</i>	View all data log points
ERASE	<i>All Erase</i>	Erase all logs
ERASE ALL?	<i>Erase?</i>	Confirm to erase all logs
BACKLITE	<i>Backlight</i>	Enable or disable backlight
ENABLE	<i>Disable</i>	<i>Disable</i> backlight
DISABLE	<i>Enable</i>	<i>Enable</i> backlight
AO CAL	<i>Analog Output Calibration</i>	Enter <i>Analog Output Calibration</i> menu
BACKUP	<i>Backup</i>	Enter <i>Backup</i> menu
SAVE?	<i>Save?</i>	Save current parameters to backup restore
LOAD?	<i>Load?</i>	Load parameters from backup restore
DEFAULT	<i>Default</i>	Restore factory default parameter settings
DEFAULT?	<i>Reset Defaults</i>	Confirm factory reset
INFO	<i>Info</i>	Enter <i>Info</i> menu
SOFT	<i>Software</i>	Display software ID number
VER	<i>Version</i>	Display software version number
MODEL	<i>Model</i>	Display model number

Advanced Menu Programming (ADVANCE)

To simplify the setup process, functions not needed for most applications are located in the *Advanced* menu. Access the *Advanced* menu features by pressing **Enter** at the *Advance* menu in the Main Menu defined on page 29. Press the **Enter** button to access any menu or press the **Up**-arrow button to scroll through choices. Press the **Menu** button to back out of a menu or hold the **Menu** button to exit at any time.

The *Advanced* menu is used to select:

- Open Collector Output Configuration (OUTPUT)
- Analog Output Configuration (A OUT)
- Math channel functions (MATH)
- Gate Function for Low Speed Inputs (GATE)
- Set the Input Filter (FILTER)
- Set Low Flow Cutoff (CUTOFF)
- Scale the Rate Input and Override K-Factor (SCALEAL)
- Select Method of Total and Grand Total Reset (T RESET)
- Set Passwords (PASSWORD)
- Reconfigure the *Main* Menu Structure (CUSTOM)
- Enter the *System* Menu for Scanner Operation and Data Logging (SYSTEM)
- Configure Serial Communication Settings (COMM)

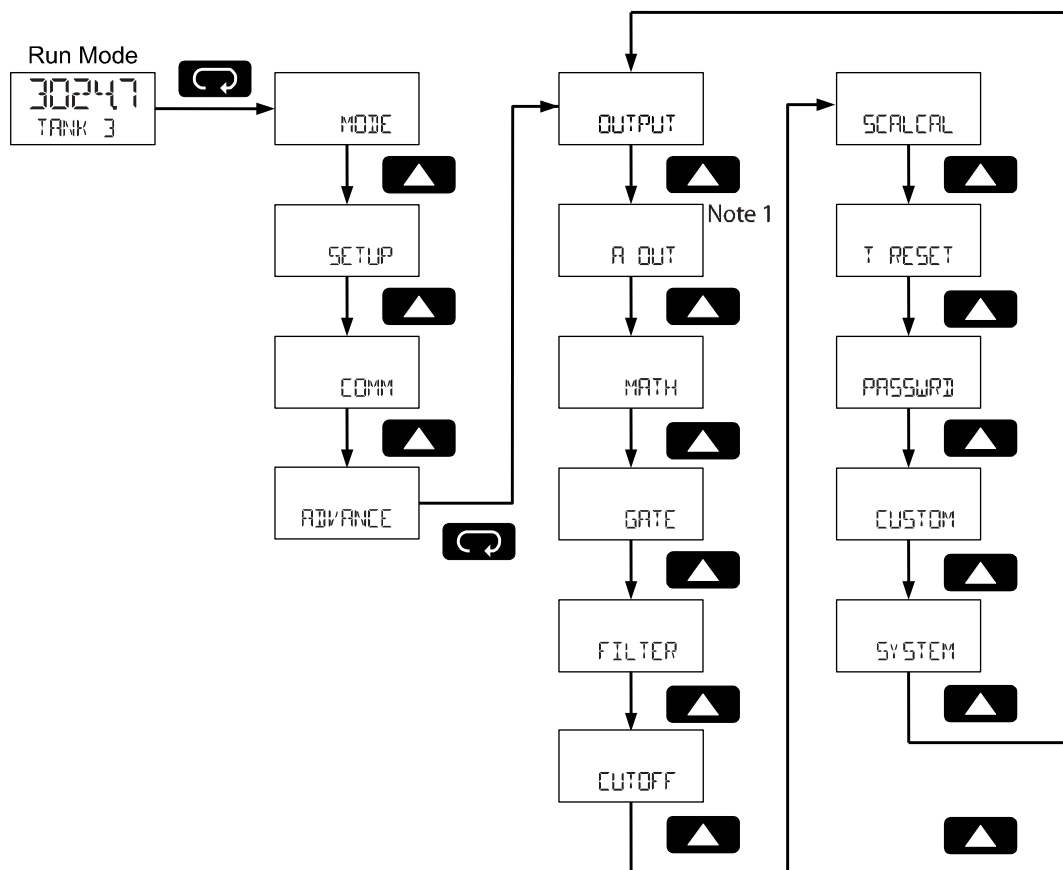

Note 1: Analog Output (A OUT) menu displayed only for scanners with the analog output option.

Open Collector Outputs (OUTPUT)

The scanner is equipped with two NPN open collector outputs that may be set up for pulse outputs, alarms, timed pulses, or turned off.

Pulse outputs can be based on the rate, total or grand total counts, one-for-one retransmit for input pulses, a Modbus PV value, or math channel value. Both outputs may be used to generate a quadrature output based on any pulse menu output type. An output test mode is also selectable to generate pulses at a constant programmable frequency.

Alarms are available based on a Modbus PV, math channel, rate, total, or grand total. The alarm status will show on the display even if the output is not wired. The outputs may also be forced on or off.

A timed pulse output generates constant pulses at a specified frequency and on time.

The output may be disabled by selecting *OFF*.

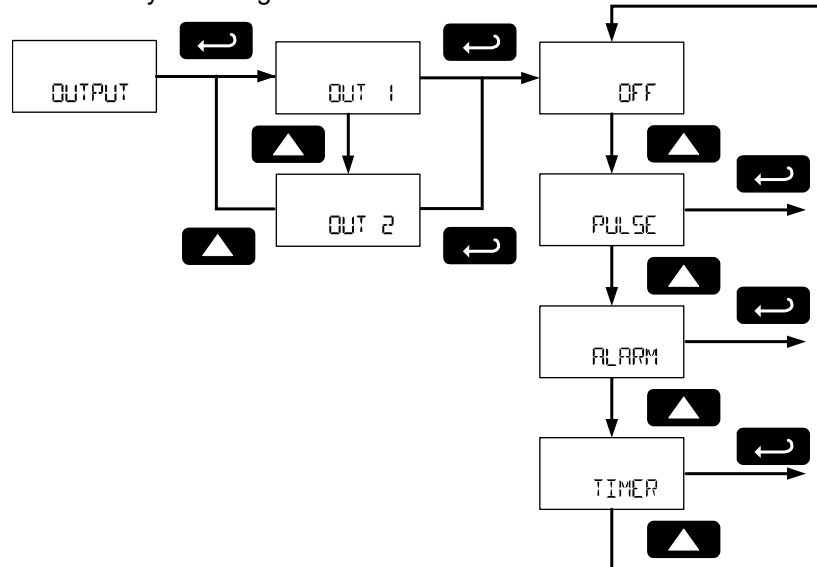

Output 1 and 2 Setup (OUT 1, OUT 2)

The function of open collector output 1 and 2 is configured using the *Off* (OFF), *Pulse* (PULSE), *Alarm* (ALARM), and *Timer* (TIMER) menus detailed below.

In the *Output 1 and 2* menus, use the **Up** button to scroll through the menu choices. Press **Enter** to make a selection and proceed to the next menu.

See Setting Numeric Values on page 24 for more information on programming numeric count, set, and reset value.

Pulse Output (PULSE)

Pulse outputs may be assigned to: rate (RATE); total (TOTAL); grand total (Gr TOTAL); retransmit (RETRAN); quadrature (QUAD); Modbus PV or math channel (PV); or test (TEST).

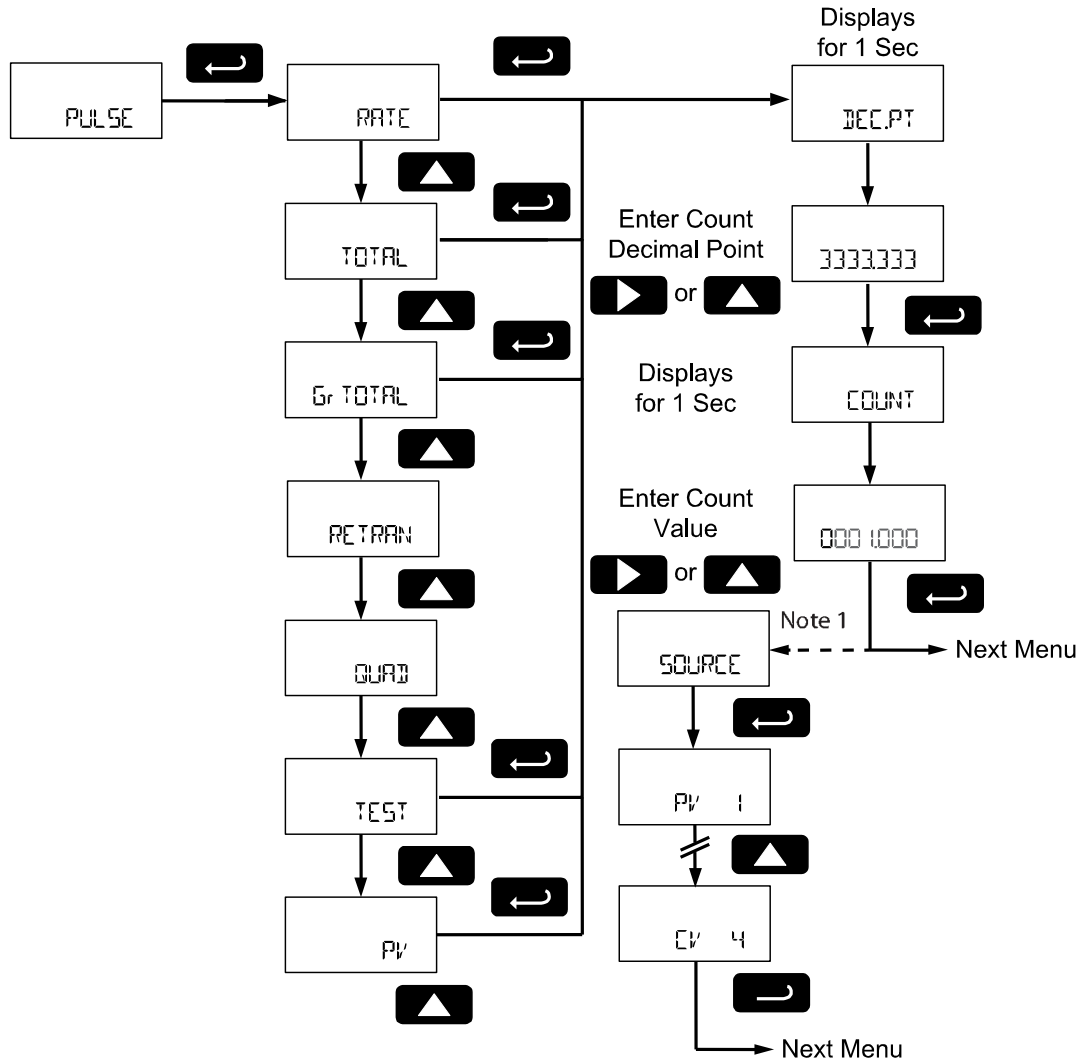

Note 1: SOURCE menu only applicable to PV option. RATE, TOTAL, Gr TOTAL, and TEST will not ask for a source.

Input Pulse Rate Pulse Output (RATE)

A pulse rate based pulse output is a factor of the rate display and count (or divisor). The rate display is a factor of the input pulses, time base, and the input k-factor. The rate of output pulses over one time base (seconds, minutes, hours, days) is defined below in terms of input pulses, the input k-factor, and count parameters.

$$\text{Number of Output Pulses} = \frac{\left(\frac{\text{Input Pulses}}{\text{Input K-Factor}} \right)}{\text{Count}}$$

For example, if the input k-factor value is set to 10, and the count set to 10, one output pulse is generated for every 100 input pulses.

Total & Grand Total Pulse Output (TOTAL, Gr TOTAL)

A total and grand total based pulse output is a factor of the associated total and count (or divisor). A pulse will be generated for every total accumulation amount equal to the count.

Retransmit Pulse Output (RETRAN)

The retransmitting pulse output will send an output pulse for every input pulse, essentially duplicating the input signal. The output will generate a pulse at the falling edge of every input pulse.

No additional programming is required for a retransmitting pulse output.

Quadrature Pulse Output (QUAD)

The pulse output set to quadrature will duplicate the other open collector output, but lag by $\frac{1}{4}$ duty cycle (90 degrees out of phase). For example, Out 1 will follow Out 2, if Out 1 is set to QUAD. Only one output should be set to QUAD. If both outputs are set to QUAD, both outputs will be disabled. The other output should be programmed as desired for the quadrature output function, and must be a pulse (PULSE) output selection.

Test Pulse Output (TEST)

The test output setting programs the output to generate pulses at a programmed constant frequency. Set the frequency decimal point location in the *DELT* menu, and then enter the desired output frequency in Hz in the *PULSE* menu.

Modbus PV or Math Pulse Output (PV)

The pulse output may be based on an enabled Modbus PV or math channels CV1 to CV4. The pulse output frequency in hertz (Hz) is calculated as the value of the selected PV or CV divided by the programmable count (or divisor).

$$\text{Output Frequency (Hz)} = \frac{(\text{PV or CV Value})}{\text{Count}}$$

The frequency of the pulse output will update as the PV or CV value is changed.

For example, if the output is set to reference PV 2, and PV 2 is reading 1540.5, with a count or 10, the pulse output frequency will be 154.05 Hz.

Alarm Output (ALARM)

Alarm outputs may be assigned to: Modbus PV or math channel (PV NUM); rate (RATE); total (TOTAL); grand total (GRTOT); always on (ON), or always off (OFF).

Alarm outputs may be assigned to rate, total, or grand total; or be forced on or off.

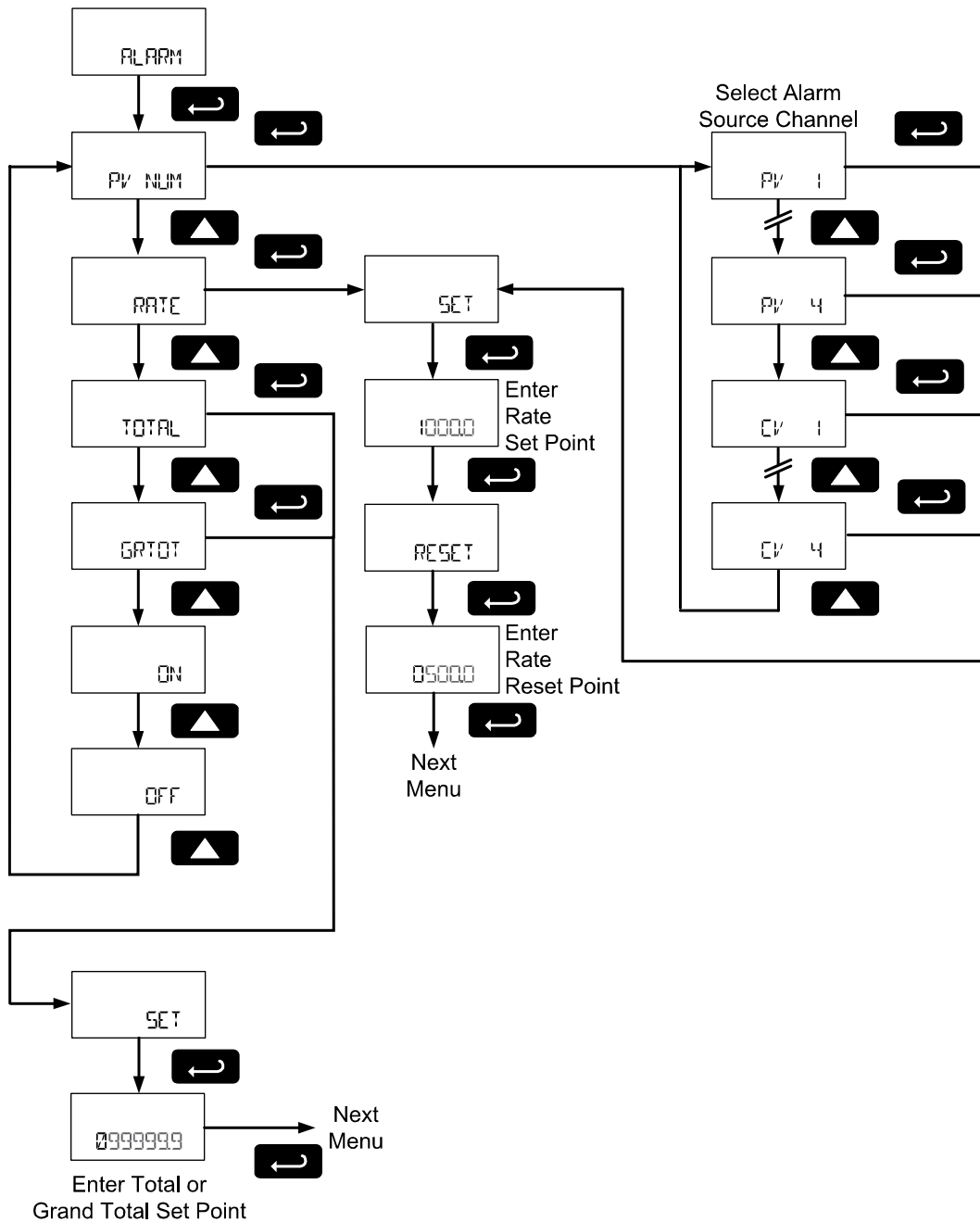

Modbus PV or Math Alarm (PV NUM)

Program a PV (PV1-16) or math channel (CV1-4) to trigger an alarm. Select the source PV or CV for the alarm and enter the display value set and reset points. The alarm deadband is determined by the difference between set and reset points. Minimum deadband is one display count. If set and reset points are programmed the same, output will reset one count below set point.

Pulse Rate Alarm (RATE)

Program the pulse rate display set point to trigger the alarm. The rate alarm deadband is determined by the difference between set and reset points. Minimum deadband is one display count. If set and reset points are programmed the same, output will reset one count below set point.

Total or Grand Total Alarm (TOTAL, GRTOT)

Program total or grand total *Set* point. A pulse alarm will generate when the *Set* value is reached by the total or grand total.

If the total/grand total is set for manual reset, this alarm will remain until the total/grand total is reset to 0.

If automatic total/grand total reset is enabled, the output will generate an alarm for a period of time programmed in *ADVANCE* → *T RESET* → *TOTAL* → *AUTO* → *T DELAY*. After this time delay, the total/grand total will reset to 0 and the alarm will clear.

If Out 1 and Out 2 are set for total or grand total alarm, the auto reset will be triggered on the highest of the two alarm set points.

For details on setting the total or grand total automatic reset time delay, see Total Reset (*T RESET*) on page 70.

Force On State (ON)

This alarm mode forces the output to be active, or on. This mode is primarily used to test alarm systems.

Force Off State (OFF)

This alarm mode forces the output to be inactive, or off. This mode is primarily used to test alarm systems.

Timer Output (TIMER)

The timer output produces a constant width pulse at a constant frequency. Program the *Period* (*PERIOD*) for one time period from 0.1 to 999999.9 seconds (time from the start of one pulse to the start of the next pulse).

Program the *On Time* (*TIME*) for the active low pulse from .01 to 99999.99 seconds (pulse width). The *on* time must be less than the delay time.

Select *Start* (*START*) to begin outputting the constant timed pulse.

Select *Stop* (*STOP*) to end outputting the constant timed pulse.

Math Channel (CV1 to CV4) Programming (MATH)

The scanner includes four math channels, CV1 to CV4. Each math channel is constructed by selecting a math function and the desired parameters.

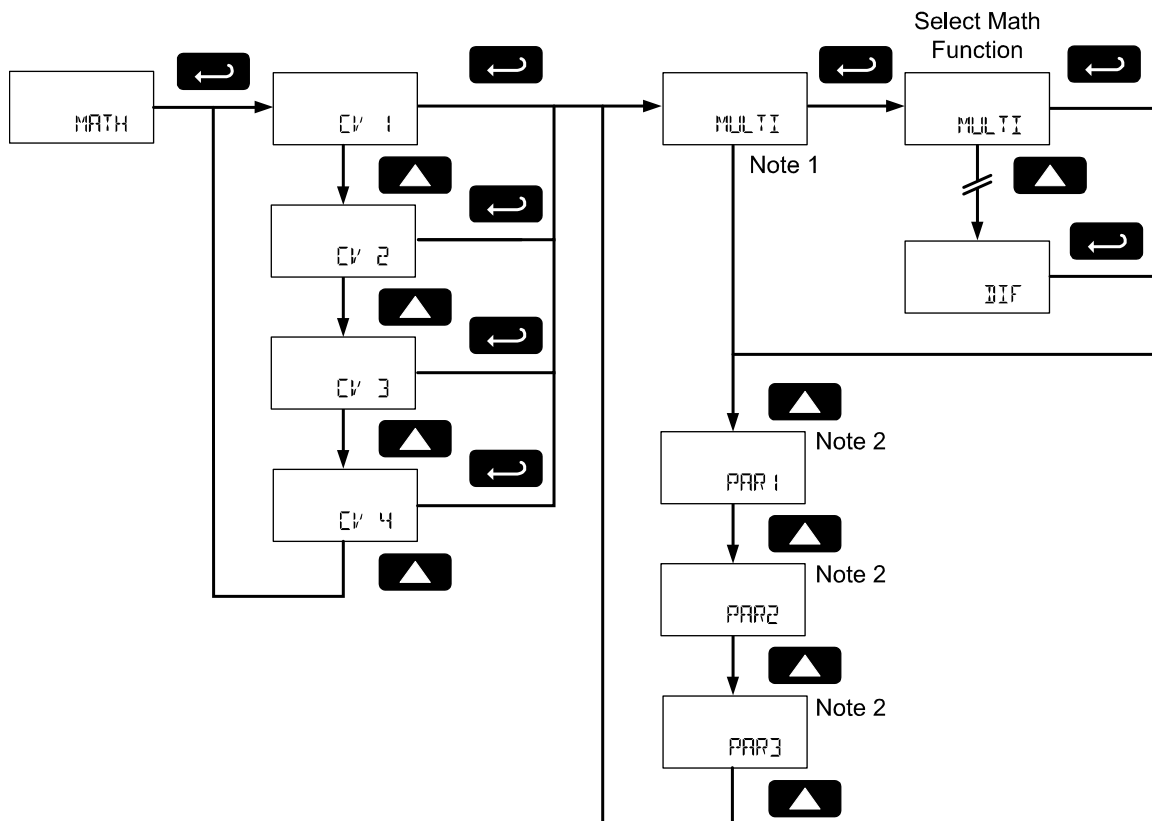

Note 1: The current math function selection will display as this menu item.

Note 2: Parameter 1, 2, and 3 will appear in the menu structure based on their use in the selected math function. See the table below for information on what parameters are necessary for each math function. If Constant is selected as the math function, the value will be immediately entered.

The available math functions are detailed below.

Math Selection	Function	Equation
SUM	Addition	PAR1 + PAR2
DIF	Difference	PAR1 - PAR2
MULTI	Multiplication	PAR1 * PAR2
DIVIDE	Division	PAR1 / PAR2
DIFABS	Absolute diff.	Abs(PAR1 - PAR2)
WAVG	Weighted avg.	((PAR1 - PAR2)*PAR3) + PAR2
DRAW	Draw	((PAR1 / PAR2) - 1) * PAR3
RATIO	Ratio	(PAR1 / PAR2) * PAR3
CONCEN	Concentration	PAR1 / (PAR1 + PAR2) * PAR3
CONST	Constant	Constant value of 0.0001 to 99999
NONE	None	Disable
ABS	Absolute Value	Abs(PAR1)
SQRT	Square Root	√(PAR1)

The available parameters for PAR1, PAR2, and PAR3 shown above are detailed below.

PAR Selection	Parameter	Description
PV 1	Modbus PV1	The scaled PV1 value; PV2 to PV16 also selectable
CV 1	Math Channel CV1	The math channel CV1 value; CV2 to CV4 also selectable
RATE	Rate	The pulse rate display rate value
TOTAL	Total	The total display value (will only display if enabled)
Gr TOTAL	Grand Total	The grand total display value (will only display if enabled)
ABS	Nested Absolute Value*	Abs(L2 PAR1)
SQRT	Nested Square Root*	$\sqrt{L2 PAR1}$
SUM	Nested Addition*	L2P1 + L2P2
DIF	Nested Difference*	L2P1 - L2P2
MULTI	Nested Multiplication *	L2P1 * L2P2
DIVIDE	Nested Division*	L2P1 / L2P2
DIFABS	Nested Absolute diff. *	Abs(L2P1 - L2 PAR2)
WAVG	Nested Weighted avg.*	$((L2P1 - L2P2) * L2P3) + L2P2$
DRAW	Nested Draw*	$((L2P1 / L2P2) - 1) * L2P3$
RATIO	Nested Ratio*	$(L2P1 / L2P2) * L2P3$
CONCEN	Nested Concentration*	$L2P1 / (L2P1 + L2P2) * L2P3$
CONST	Constant	Constant value of 0.0001 to 99999
NONE	None	No parameter.

*Selecting this math function as a parameter will enter into the setup for a Nested Math Function. These parameters are not available for level 2 parameters used when setting up the nested math function.

Nested Math Functions

To create more complicated math functions, the first level parameters allow a math function to be selected as the parameter. In this case, a second level of parameters is selected for the nested math function. These level 2 parameters are level 2 parameter 1, L2P1 (L2P1); level 2 parameter 2, L2P2 (L2P2); level 2 parameter 3, and L2P3 (L2P3). Level 2 parameters are selected similarly to other math parameters; however additional nested math functions are unavailable for selection.

Entering a Constant Value

To enter a constant value, press **Enter** to select Constant (CONST). Value (VALUE) will display. Press **Enter** to confirm and enter a constant value. V.DP will display. Use the **Up** and **Right** arrows to select the number of decimal points used in the constant value. Press **Enter** to select the number of decimal points selected. Value will display. Set the constant value. See Setting Numeric Values on page 24 for more information.

No Parameter (NONE)

Selecting a parameter of None will disable the math function. Any math function with a parameter of None will display None (NONE) on the display as the value of the math function.

Gate Function (GATE)

The gate function is used for displaying slow pulse rates. Using the programmable gate, the meter is able to display pulse rates as slow as 1 pulse every 9,999 seconds (0.0001 Hz). The gate function can also be used to obtain a steady display reading with a fluctuating input signal.

There are two settings for the Gate, low gate (LO GATE) and high gate (HI GATE).

Low Gate (LO GATE)

For most applications, low gate setting should be left at 1 second. Increase low gate setting to obtain a steadier rate display. The rate display will update in accordance with the low gate setting, for example if low gate is set at 10, the display will update every 10 seconds; changes in rate between updates will not be reflected until next display update. The low gate may be set from 1 to 99 seconds.

To enter the *Low Gate*, press **Enter** to select *Low Gate (LO GATE)* and program the gate setting in seconds. See Setting Numeric Values on page 24 for more information.

High Gate (HI GATE)

Set the high gate value to correspond to the highest expected pulse period (lowest pulse rate). For instance, if the meter must display a rate when there is 1 pulse coming into the meter every 10 seconds, set the high gate to 11 seconds. When the signal is removed from the meter, the display will show the last reading for 11 seconds; then it will read zero.

To enter the *High Gate*, press **Enter** to select *High Gate (HI GATE)* and program the gate setting in seconds. See Setting Numeric Values on page 24 for more information.

Contact Debounce Filter (FILTER)

The filter function (FILTER) can be used for applications where the meter is set up to count pulses generated by switch contacts. There are three settings, HI (high speed), LO (low speed), and MED (medium speed). High speed disables the contact debounce filter and allows any pulse of the minimum specified width for the selected input type.

The medium filter ignored signals faster than 250 Hz max, or pulse widths less than 2 ms at 50% duty cycle. The low filter ignores signals higher than 100 Hz, or pulse widths less than 5 ms at 50% duty cycle. Press the **Up** arrow to cycle through the *Filter* options. Press **Enter** when HI, LO, or MED is displayed to enable that filter setting.

Low-Flow Cutoff (CUTOFF)

The low-flow cutoff feature allows the meter to be programmed so that the often-unsteady output from a transmitter at low flow rates, always displays zero on the meter.

The cutoff value may be programmed from 0 to 99999. Below the cutoff value, the meter will display zero. Programming the cutoff value to zero disables the cutoff feature.

To enter the *Cutoff*, see Setting Numeric Values on page 24 for more information.

Pulse Input Scaling & Calibration (SCALCAL)

It is **very important** to read the following information, before proceeding to program the meter:

There is **no need to recalibrate** the meter for frequency in Hz when first received from the factory.

The meter is **factory calibrated** for Hz prior to shipment. The calibration equipment is traceable to NIST standards.

 IMPORTANT	<p>Performing a pulse input scaling operation will override any k-factor programming. Similarly, completing the k-factor menu will override any pulse input scaling operation performed on the meter. Verify the method of programming required and use the password protection feature to secure the meter if necessary.</p>
---	--

There are two methods of programming the pulse input rate display to show the correct engineering units. Use the *KFactor* menu to enter a k-factor. This is the most common way to program the pulse input. For details on scaling the meter using the k-factor, see Entering the K-Factor (KFACTOR) on page 53. Use the *Pulse Input Scaling & Calibration* menu to scale the pulse input using up to 32 input and display points. Each point includes a frequency input and a corresponding display value. All scale points are scaled linearly.

Undoing K-Factor or Scale Programming (UNDO? KFACTOR)

Whenever the input programming is being changed from using k-factor to scaling; or from scaling to k-factor, a confirmation menu appears. This prevents accidental changing of the input programming.

The example below shows a meter programmed with a k-factor being reprogrammed to utilize pulse input scaling.

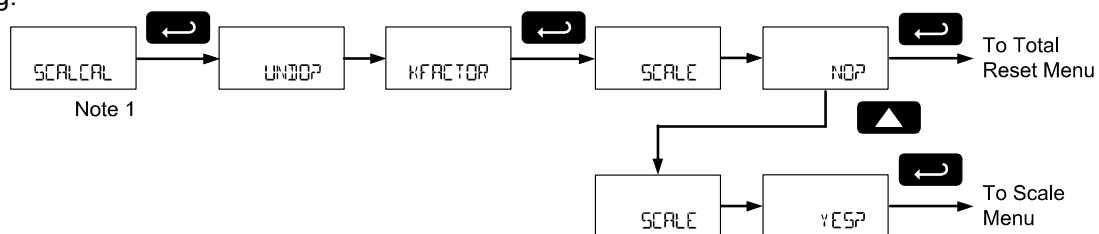

Note 1: The Undo? menu will appear after the Scaling and Calibration menu if the scanner pulse inputs are programmed with a k-factor. If a scaling operation has already been performed, the Undo? menu will appear after the K-Factor menu instead.

Scaling the Pulse Rate Input (SCALE)

The *Scale* menu is used to scale the pulse rate input to display the pulse input in engineering units. This is an alternative method of pulse input rate programming to using a k-factor. A signal source is not needed to scale the meter; simply program the inputs and corresponding display values.

To use the scale menu, a minimum of two points are defined by an input frequency and a display value. The scaling points then linearly scale the pulse input.

The *Input* menus are entered as pulse input frequencies (Hz). The *Display* values are entered in chosen engineering units. The engineering units for the rate input are defined by a volume unit and a time base. A scale programmed input will work with Automatic Unit Conversions as described on page 50.

For example, if the *Rate Input Unit* is gallons, and the time unit (ENGINE UNIT) is seconds, the units for the pulse rate input scaling is gallons/second. The Rate display units are selected separate, in Pulse Rate Display Setup (RRATE) on page 44.

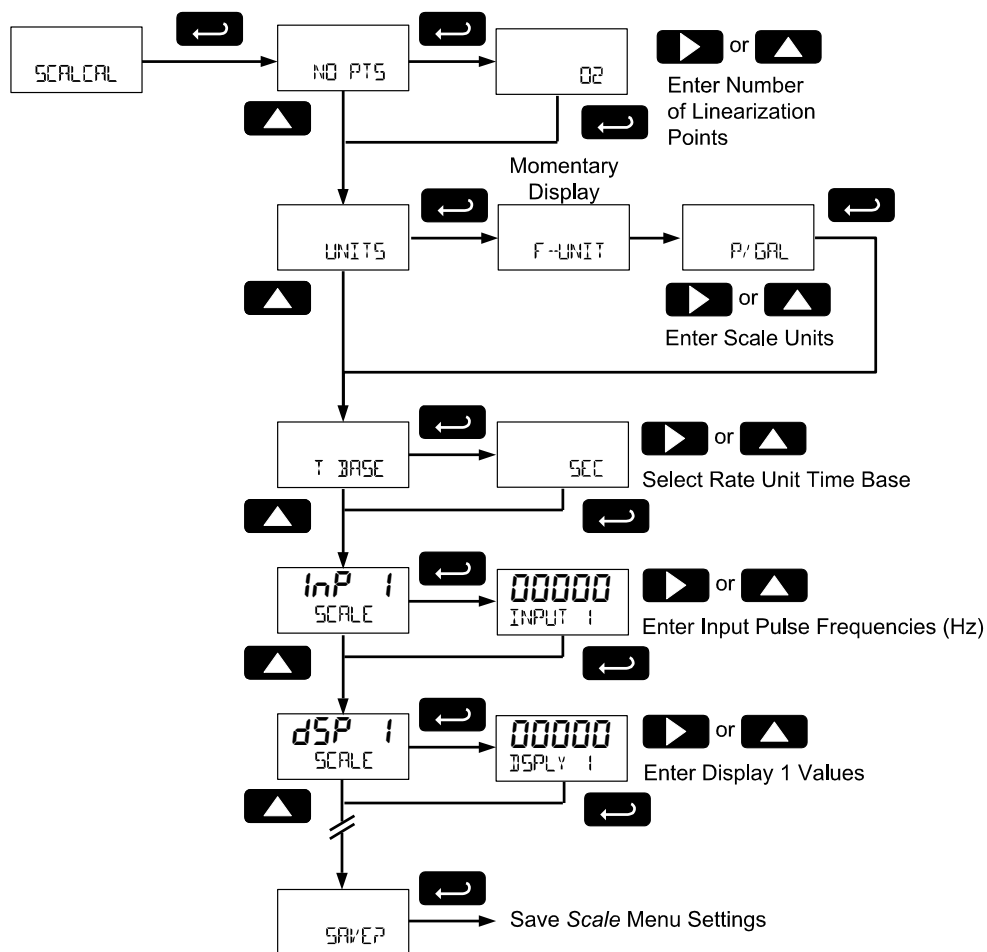

Use the **Enter** button to enter a menu selection or confirm an entry. Use the **Up** button for selecting engineering units. For instructions on how to program numeric values see page 24.

Number of Points (NO PTS)

Enter number of linearization points. The default value is 2 points. For linear inputs requiring only 2 scale points, the number of points can be left at 2.

Up to 32 linearization points can be selected under the *Number of Points* function. This allows for the linearization of non-linear inputs.

Scale Units (UNITS)

Enter the units associated with the desired pulse input rate scale values. Selecting the pulse input rate scale units allows the meter to perform automatic unit conversions.

Note: This is not the rate display unit. Entering this unit defines the scaling only. For example, a flowmeter may output 0 Hz at 0 gallons per minute, and 1000 Hz at 250 gallons per minute. In this case, the scale units would be entered as gallons at a time base or minutes. However, the rate display units are chosen in Pulse Rate Display Setup (RATE) on page 44. This allows for the Rate Units menu to be used to automatically change the rate display to accurately display any rate unit desired.

Pulse Input Time Base (T BASE)

This is the time component pulse rate input scaling engineering unit. Enter the appropriate units/second, units/minute, units/hour, or units/day that corresponds to the values being entered at the *display 1-32* (dSP) menus.

Scale Point Entry (INP, DSP)

Enter the pulse rate frequency in pulses per second (Hz) for each of the scale points (INP 1-32). After each frequency input, enter the value in engineering units that corresponds to that input frequency. Up to 32 points may be programmed, as determined by the *Number of Points* (NO PTS) parameter.

Each scale input point is defined by an input frequency and a corresponding display value.

The frequency inputs may be entered with up to three decimal places. To access the decimal location digits when entering a frequency, use the **Right** button to scroll to the three decimal location digits.

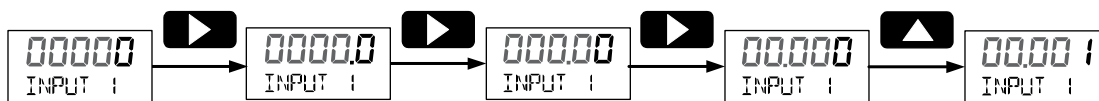

Save Scaling Points (SAVEP)

After entering the last display value, the scaling entries must be saved (SAVEP) before they will be put into effect. *However*, you may move past this selection using the Up arrow key if you need to go back and correct an earlier entry. Once confident in the entries, however, the user must navigate back to the Save menu screen (SAVEP) and press the Enter key to save the changes.

Calibrating the Pulse Rate Input (CAL)

The *Cal* menu is used to calibrate the pulse rate input using a live signal source to display the pulse input in engineering units.

To access the *Cal* menu it is necessary to enable it using the *Custom* menu.

Total Reset (T RESET)

This menu is used to select the ways the total and grand total may be reset.

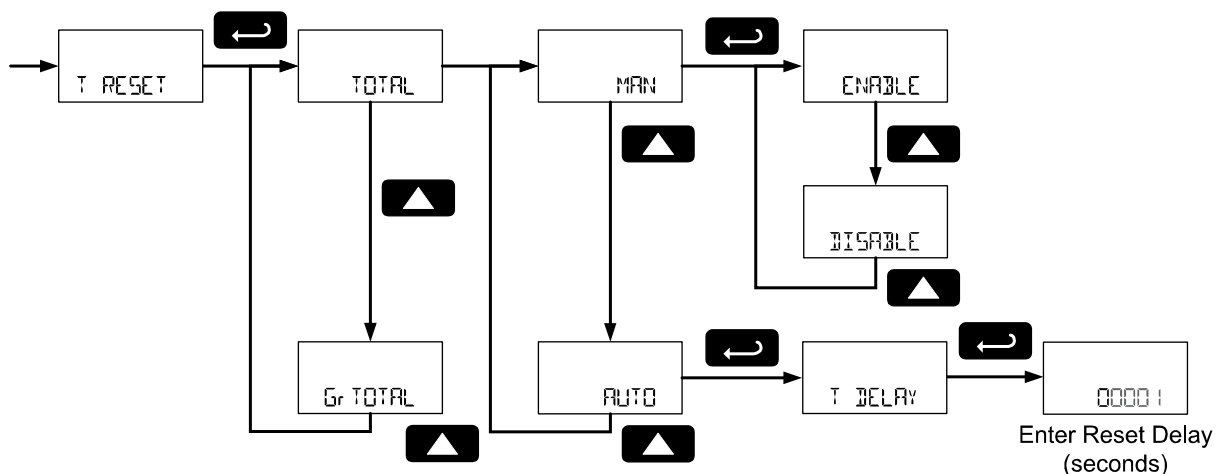

Manual or Automatic Total Reset Function (TOTAL)

For manual reset, select *Total Reset* (TOTAL) and press **Enter**. Use the **Up**-arrow button to select *Manual* (MAN) and press **Enter**. Then select whether manual reset will be enabled (ENABLE) or disabled (DISABLE) using the **Up**-arrow key. Press the **Enter** button to accept. Disabling reset will avoid inadvertent resets of the total via the front reset button or external reset contact.

For automatic reset, select *Total Reset* (TOTAL) and press **Enter**. Use the **Up**-arrow button to select *Automatic* (AUTO) and press **Enter**. Press **Enter** at *Time Delay* (T DELAY) and enter reset delay time in seconds. Once the output alarm total set point is reached, the meter waits for a programmed amount of time (T DELAY) and then resets the total to zero. To enter the *Time Delay*, see Setting Numeric Values on page 24 for more information.

Press the **Enter** button, at any time, to accept a setting; otherwise press the **Menu** button to exit without saving changes.

Total Alarm Time

The T DELAY parameter is used by the NPN open collector outputs when they are programmed as total alarms. If *Total Reset* (T RESET) is programmed to AUTO the *Time Delay* (T DELAY) is the length of the associated Out 1 or Out 2 total alarm prior to the total being reset to 0.

For information on programming the NPN open collector pulse outputs as total alarms, see Alarm Output (ALARM) programming on page 64.

Manual or Automatic Grand Total Reset Function (GTRESET)

For manual reset, select *Grand Total Reset* (GTRESET) and press **Enter**. Use the **Up**-arrow button to select *Manual* (MAN) and press **Enter**. Then select whether manual reset will be enabled (ENABLE) or disabled (DISABLE) using the **Up**-arrow key. Press the **Enter** button to accept. Disabling reset will avoid inadvertent resets of the grand total via the front reset button or external reset contact.

For automatic reset, select *Grand Total Reset* (GTRESET) and press **Enter**. Use the **Up**-arrow button to select *Automatic* (AUTO) and press **Enter**. Press **Enter** at *Time Delay* (T DELAY) and enter reset delay time in seconds. Once the output alarm total set point is reached, the meter waits for a programmed amount of time (T DELAY) and then resets the grand total to zero. To enter the *Time Delay*, see Setting Numeric Values on page 24 for more information.

Press the **Enter** button, at any time, to accept a setting; otherwise press the **Menu** button to exit without saving changes.

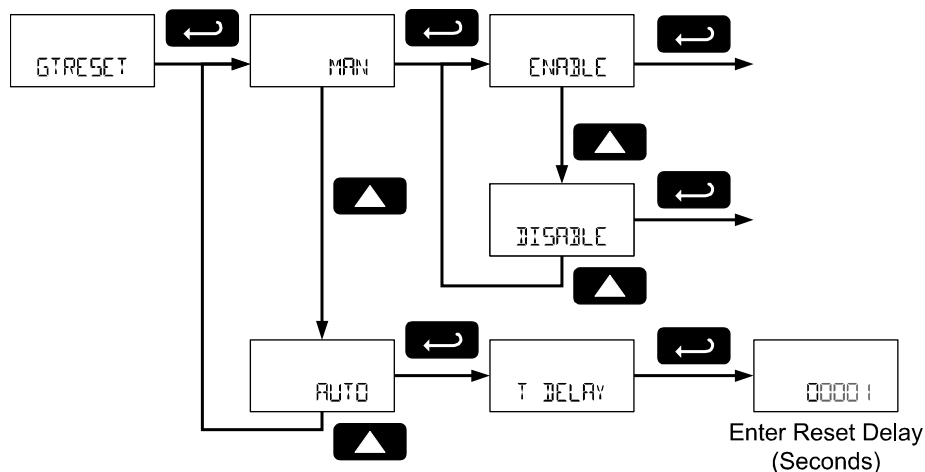

Grand Total Alarm Time

The T DELAY parameter is used by the NPN open collector outputs when they are programmed as total alarms. If *Grand Total Reset* (GTRESET) is programmed to AUTO the *Time Delay* (T DELAY) is the length of the associated Out 1 or Out 2 total alarm prior to the total being reset to 0.

For information on programming the NPN open collector pulse outputs as total alarms, see Alarm Output (ALARM) programming on page 64.

Setting Up Passwords (PASSWORD)

The *Password* menu is used to program a five-digit password to prevent unauthorized changes to the programmed parameter settings, to restrict the ability to reset the total and grand total, and to permanently lockout the ability to reset the grand total and any grand total related parameters. The lock symbol is displayed on decimal display models to indicate that settings are password protected. Record all passwords for future reference. If appropriate, it may be recorded in the space provided. For instructions programming numeric values see Setting Numeric Values on page 24 for more information.

Model	Password
Serial Number:	
Setting Lockout Password (PASS):	_____
Total Reset Password (PASS T):	_____
Grand Total Reset Password (PASS GT)	_____

Locking Scanner Setup Parameters (PASS)

Enter the *Password* menu by pressing **Enter**. Select *Password* (PASS) by pressing **Enter**. Program a five-digit password. The scanner will return to *Run Mode* after locking any of the passwords.

Making Changes to a Password Protected Scanner

If the scanner is password protected, the scanner will display the message LOCKED when the **Menu** button is pressed. Press the **Enter** button while the message is being displayed and input the correct password followed by the **Enter** button to gain access to the menu. After exiting the programming mode, the scanner returns to its password protected condition.

Password Restricting Total & Grand Total Reset (PASS T, PASS GT)

To restrict resetting of the total, enter the *Password* (PASS) menu by pressing **Enter**. Press the **UP** button to display the *Total Password* (PASS T) or **Up** again to display the *Grand Total Password* (PASS GT) and press **Enter**. Program a five-digit password. This will deactivate the remote reset connections. Total will only be able to be reset through the through-glass buttons or mechanical pushbuttons, if the appropriate password is entered.

Resetting Total & Grand Total on a Password Protected Meter

If the meter is password protected for total or grand total reset, the meter will display the message PASS T or PASS GT when an attempt is made to enter the password protected total or grand total *Reset* menus. Input the password and press the **Enter** button to reset the total or grand total.

The password requirement may be disabled by entering the password in the *Password* menu for total (PASS T) or grand total (PASS GT).

Disabling Password Protection

To disable the password protection, access the *Password* menu, select the type of password to be disabled, and enter the programmed password. That password is now disabled until a new password is entered.

 IMPORTANT	<p>Did you forget the passwords?</p> <p>The password may be disabled by entering a master password. If you are authorized to make changes, enter the master settings lockout (PASS) password 50865, the master total reset (PASS T) password 80034, or the master grand total reset (PASS GT) password 80034 to unlock the scanner.</p>
---	--

Non-Resetable Grand Total

The grand total may be configured to be a non-resettable grand total. This is a permanent setting. Configuring the grand total as a non-resettable grand total locks out all setup parameters that could be used to reset the grand total or change the setup of the grand total; including pulse input selection, rate scaling, and conversion factors.

To configure the meter for non-resettable grand total mode, enter the non-resettable grand total password below into the *Pass GT* (PASS GT) parameter in the *Password* (PASS) menu.

The non-resettable grand total permanently locks the following parameters from being changed: pulse input selection, K-factor, K-factor units, grand total units, grand total conversion factor, grand total decimal point, scaling, calibration, grand total alarms, pulse input filter, and cutoff.

 CAUTION	<p>Locking the meter into a non-resettable grand total is not reversible. It is a permanent meter configuration. Doing so will permanently prevent most pulse input parameters from being altered. This should be the last step after verifying all setup parameters.</p>
---	---

Non-resettable grand total password: 50873

Non-Resetable Grand Total Locked Menus & Parameters

Display	Parameter/Menu	Action/Setting Locked
PULSEIN	<i>Pulse Input</i>	All <i>Pulse Input</i> type selection menu parameters
GTOT U	<i>Grand Total Units</i>	Set grand total units
GT-CF	<i>Grand Total Conversion Factor</i>	Enter the <i>Grand Total Conversion Factor</i> menu
GRTOT.DP	<i>Grand Total Decimal Point</i>	Enter the grand total display decimal point
KFACTOR	<i>K-Factor</i>	All <i>K-Factor</i> menu parameters
SCALE	<i>Scale</i>	All <i>Scale</i> menu parameters
PASS GT	<i>Password Grand Total</i>	Enter the grand total reset password
GRTOT	<i>Grand Total Alarm</i>	All grand total alarm output menu parameters
FILTER	<i>Filter</i>	Enter <i>Filter</i> parameter
CUTOFF	<i>Low-Flow Cutoff</i>	Enter <i>Low-Flow Cutoff</i> parameter

The above menus remain accessible; however the parameters listed above within the menus are locked and may not be changed.

Custom (CUSTOM)

The *Custom* menu is used to modify the initial programming menus that appear in the Main Menu when the **Menu** button is pressed in Run Mode.



Changing the default menu setup with the *Custom* menu feature may change the setup and operation procedures described in this manual. Only operators familiar with the programming and operation of this unit should use this feature.

Eight menu positions are available. Menu positions 6 and 7 are factory programmed for *Setup* and *Advanced*.

After pressing **Enter** at the *Custom* menu, the display will flash *Position (POS 1)* and then display the parameter to appear in position 1 of the main menu.

To add a menu or parameter to the menu structure, or change the default menus, press **Enter** at the desired position (POS) to be edited, and use the **Up** or **Right** arrows to select the desired menu item for that position. Press **Enter** to save the setting. See page 75 for a complete list of the available menu selections for each position.

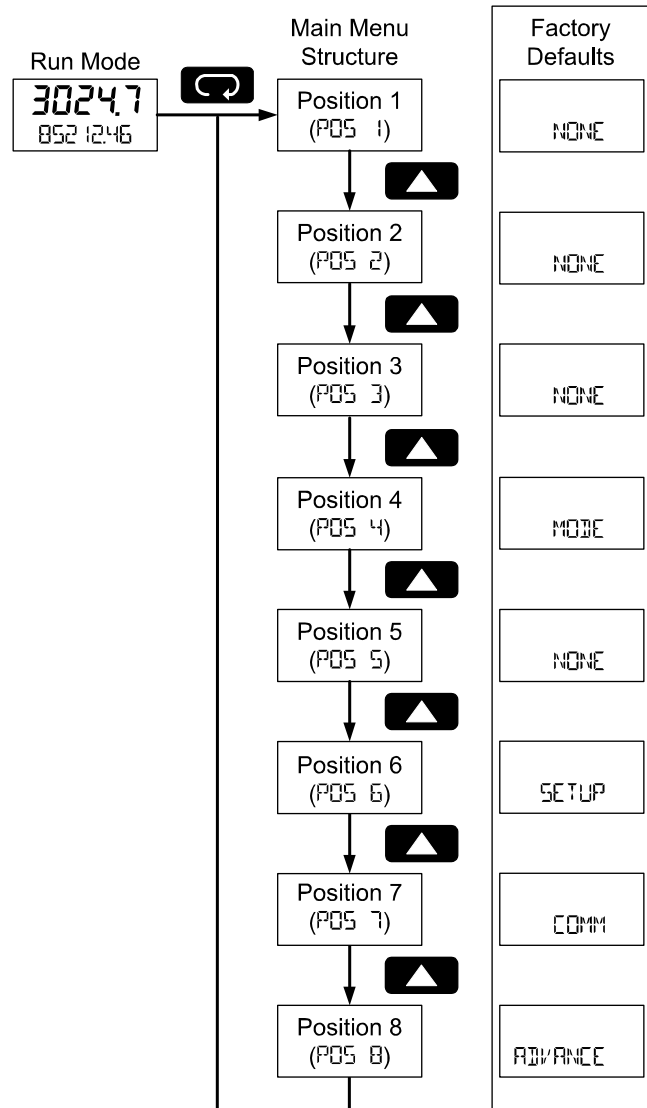

Custom Menu Parameters

Display	Parameter/Menu	Action
NONE	<i>None</i>	Set no menu position display
PULSEIN	<i>Input</i>	Set to show <i>Input</i> menu
KFACTOR	<i>K-Factor</i>	Set to show <i>K-Factor</i> menu
UNITS	<i>Units</i>	Set to show <i>Units</i> menu
DECIMAL	<i>Decimal</i>	Set to show <i>Decimal</i> menu
DISPLAY	<i>Display</i>	Set to show <i>Display</i> menu
A OUT	<i>Analog out</i>	Set to show <i>Analog Output</i> menu
RATEDP	<i>Rate decimal Point</i>	Set to show <i>Rate Decimal Point</i> menu
TOTALDP	<i>Total decimal point</i>	Set to show <i>Total Decimal Point</i> menu
GRTOTDP	<i>Grand total decimal point</i>	Set to show <i>Grand Total Decimal Point</i> menu
SCALE	<i>Scale</i>	Set to show <i>Scale</i> menu
CAL	<i>Calibrate</i>	Set to show <i>Calibration</i> menu
T BASE	<i>Time base</i>	Set to show <i>Time Base</i> menu
T FACTR	<i>Total conversion factor</i>	Set to show <i>Total Conversion Factor</i> menu
T RESET	<i>Total reset</i>	Set to show <i>Total Reset</i> menu
GTFACTR	<i>Grand total conversion factor</i>	Set to show <i>Grand Total Conversion Factor</i> menu
GTRESET	<i>Grand total reset</i>	Set to show <i>Grand Total Reset</i> menu
PASS	<i>Password</i>	Program password to lock scanner parameters
PASS T	<i>Total password</i>	Program password to prevent total reset
PASS GT	<i>Grand total password</i>	Program password to prevent grand total reset. May <i>permanently</i> lock out grand total related parameters and reset
OUTPUT	<i>Output</i>	Set to show <i>Output</i> menu
OUT 1	<i>Out 1</i>	Assign function of pulse output 1
OUT 2	<i>Out 2</i>	Assign function of pulse output 2
DATALOG	<i>Data Log</i>	Enter <i>Data Log</i> menu
LOGTIME	<i>Log Time</i>	Set daily data log times
INTERVL	<i>Interval</i>	Set interval log times
LOGVIEW	<i>Log View</i>	Enter <i>Log View</i> menu
PASSWORD	<i>Password</i>	Set to show <i>Password</i> menu
SETUP	<i>Setup</i>	Set to show <i>Setup</i> menu
ADVANCE	<i>Advance</i>	Set to show <i>Advanced</i> menu
SYSTEM	<i>System</i>	Set to show <i>System</i> menu
MODE	<i>Mode</i>	Set to show <i>Mode</i> menu
COMM	<i>Communications</i>	Enter the <i>Communications</i> menu

System (SYSTEM)

The system function is used to set the real time clock, set daily data log times, enable/disable the backlight, access analog output controls used in troubleshooting, store, restore, and backup restore feature, enable/disable the battery power alert symbol on the display, and review basic system identification information.

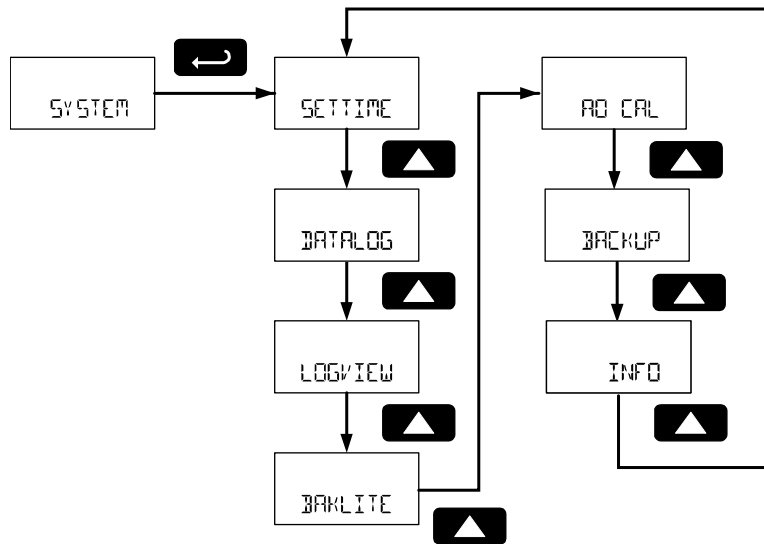

Set Real Time Clock (SETTIME)

The real time clock is used to trigger data log events and is recorded at every logged data point. The *Set Time* menu displays the date and time.

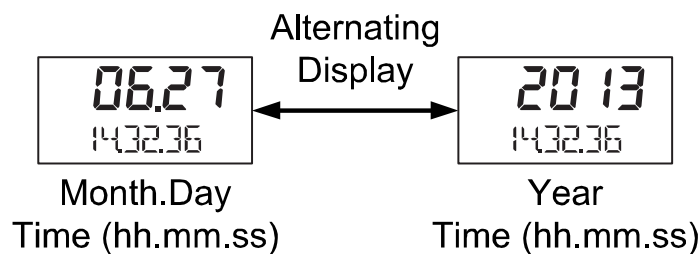

Figure 13: Real Time Clock Display Example – Decimal Display Model

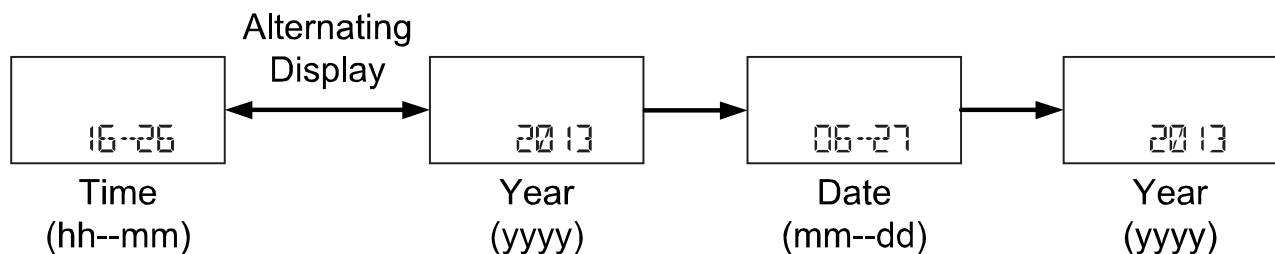
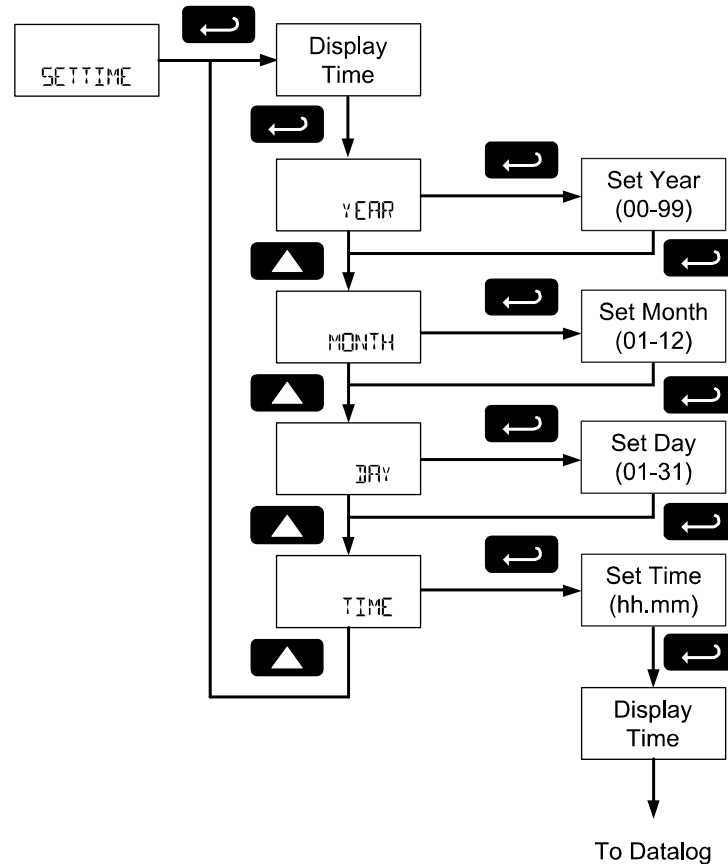

Figure 14: Real Time Clock Display Example – Feet & Inches Display Model

The above display examples show the date to be June 27, 2013; at 14 hours, 32 minutes, and 36 seconds.



The year, month, day, hour, and minute may all be set by the user. The real time clock will need to be reset if external power and battery power are lost.

To program the time, select the time or date component to be programmed, and press **Enter**. To enter the time or date as a numeric value, see Setting Numeric Values on page 24 for more information.

Changing the time (hours and minutes) will reset the second clock to 0.

Data Log Setup (DATALOG)

The *Data Log* menu is used to setup and enable the data log functions. The scanner may contain up to 511 records, each containing the date, time, and log number. Each record may hold either the first eight enabled Modbus PVs and any enabled math channel CVs; or the rate, total and grand total.

The data log can hold 511 records of the first eight enabled Modbus PVs and math channel CVs; 511 records containing the rate, total, and grand total; or 256 records of each.

The data log will make a record of the first eight enabled Modbus PVs and math channel CVs if any Modbus or math channels are enabled. The data log will make a record of the rate, total, and grand total if any of these parameters is enabled. The frequency of these records depends on the data log settings.

For example: If the pulse input is disabled, PV 1, 2, 3, and 4 are enabled, and CV 1 and 2 are enabled, the data log may record 511 logs containing PV 1, 2, 3, and 4, as well as CV 1 and 2. The data log will record these values even if CV2 is the only value set to display.

If the pulse input is enabled, the data log will record 256 logs containing PV 1, 2, 3, and 4, and CV 1 and 2. It will also record 256 logs containing the rate, total, and grand total.

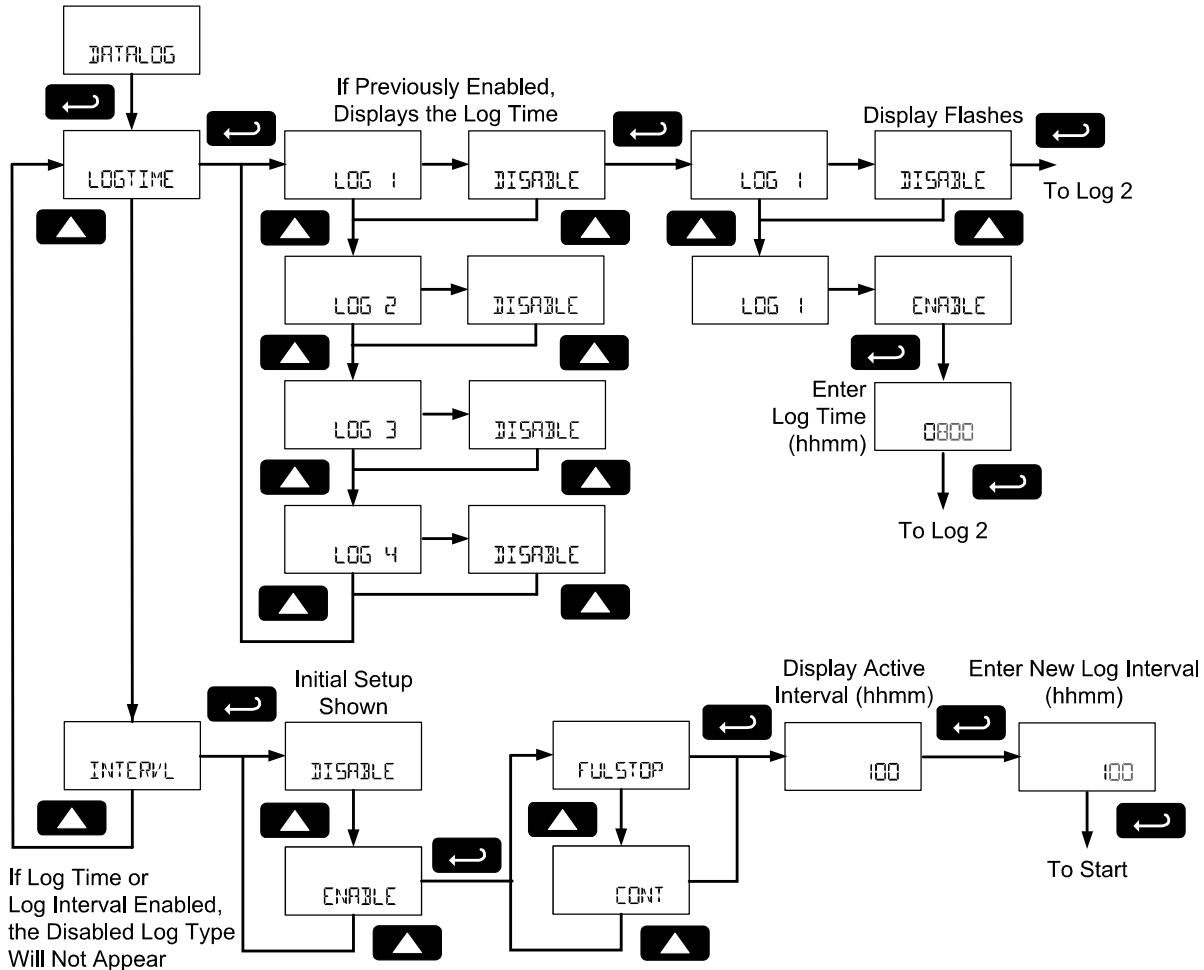

There are two ways to configure the time when a data log record is recorded. The *Log Time* feature allows up to 4 data log events time to be entered for each day. The *Log Interval* feature allows a data log recording event at after a time interval has passed. At each data log event, all appropriate data records will be recorded.

Only the *Log Time* or *Log Interval* may be active at once. While one type of data logging has been enabled, the other menu will be inaccessible.

Log Time Setup (LOGTIME)

The *Log Time* menu contains four log events (LOG 1 to LOG 4). Each log time is configured independently. For each daily log time desired, enable a log, and set the log time for the hours and minutes the log is to be recorded. The time is set in real-time hours and minutes, based on the real time clock setup.

The *Log Time* feature will roll-over, deleting the oldest data logs (in blocks of 8) when the log is full and new logs must be recorded. This makes it the most useful for long-term data logging.

Interval Setup (INTERVL)

The *Interval* menu sets the time interval for data logging. Every time interval, one data log event will be recorded. To enable interval data logging, enable the feature, and set the interval time for the hours and minutes between each log.

If set to FULSTOP, the *Log Interval* feature will not delete old data, and data logging will stop when the log is full. This makes it the most useful for short periods and logging specific functions.

If set to CONT, the *Log Interval* feature will delete the old data when full and continue logging data. The *Log Interval* feature will roll-over, deleting the oldest data logs (in blocks of 8) when the log is full and new logs must be recorded. This makes it the most useful for long-term data logging.

View Data Log (LOGVIEW)

The *Log View* menu allows on-screen browsing of the data log event records stored in the scanner. Data points may be navigated by viewing the log number, date and time, first eight enabled PVs and four CVs, rate, total, or grand total amounts. A known log may be jumped to immediately, avoiding a lengthy search for data. All logs may be deleted with the **ERASE** command, requiring confirmation.

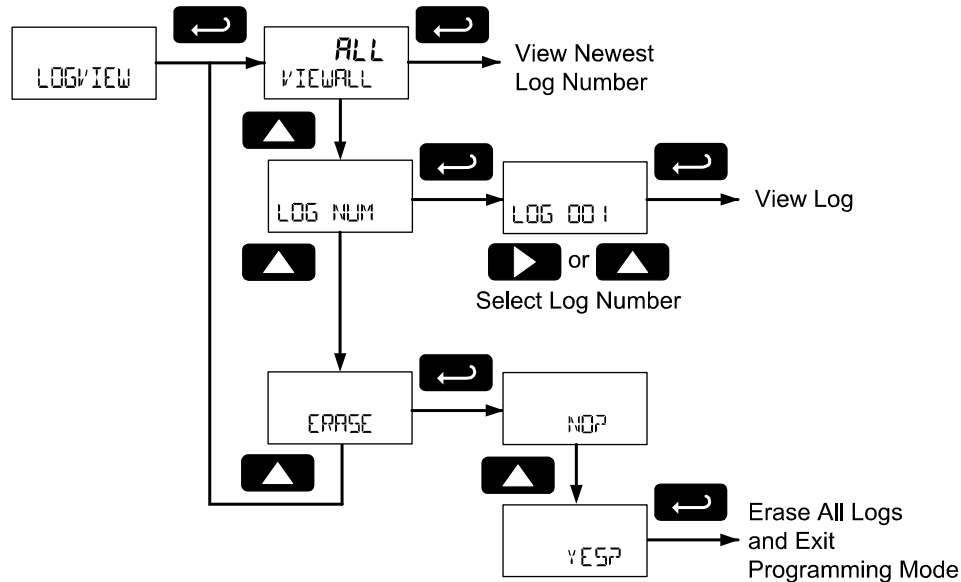

Once the log records are displayed, use the **Enter** key to display variable within the same log and move to the next log. Use the **Up** and **Right** arrows to move to the next or previous log number.

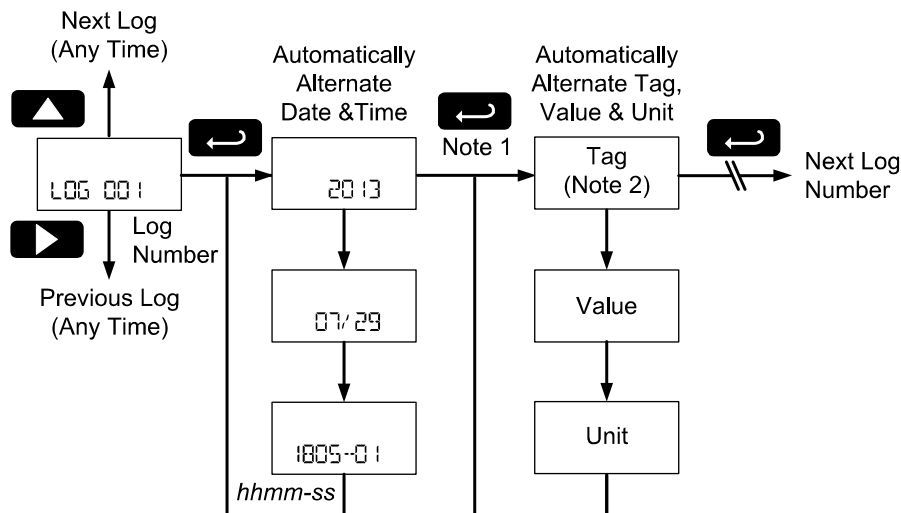

Note 1: All enabled PVs and CVs will display in order, followed by the, rate, total, and grand total if enabled. The Tag for each PV, CV, rate, total, or grand total will flash before the value.

Note 2: All tags, values, and units will appear on the lower display with exception of feet and inches formatted values on the feet and inches display models. These displays will automatically alternate on the display.

Backlight (BACKLITE)

The *Backlight* menu is used to enable or disable the backlight. After pressing **Enter** to access the *Backlight* menu, press the **Up** arrow to *Enable* (ENABLE) or *Disable* (DISABLE) for the backlight.

Analog Output Calibration (AO CAL)

This feature is only used at the factory for diagnostic purposes. It is not recommended to access this menu without instruction from technical support.

Backup & Restore (BACKUP)

The scanner saves all parameter settings and no reprogramming is necessary when power is lost and restored to the scanner. The total and grand totals are saved during a power loss.

These features are used to save and restore programmed settings. Programming can be restored to a known saved good configuration, or to factory defaults. This is useful to restore meters whose programming has been altered in unknown ways, or to quickly restore known good settings if mistakes are made during reprogramming.

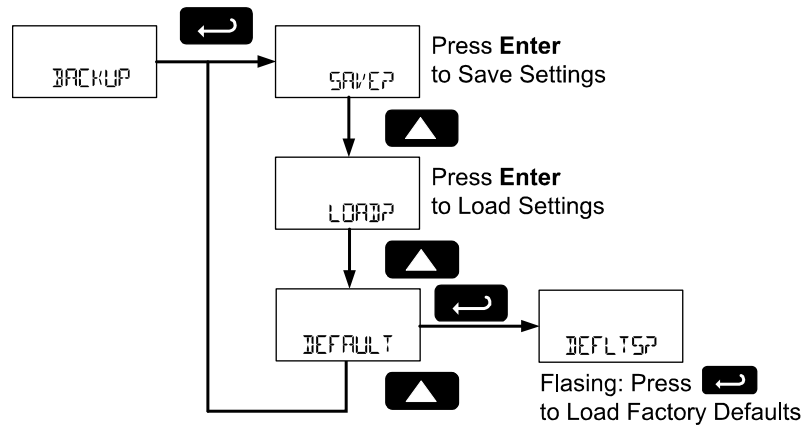

The Save feature (SAVE?) saves all current parameter settings into the memory of the backup restore.

The backup restore feature is loaded with factory default settings until a new configuration is saved.

The Load feature (LOAD?) restores all parameters to the programmed values stored in backup restore memory. The Load feature will not affect the current password settings, or allow the editing of permanently locked parameters due to the enabling of the non-resettable grand total feature. See Non-Resettable Grand Total described on page 73.

 CAUTION	<p>Once scanner parameters have been saved to memory by the backup restore feature there is no recovering the previously saved settings.</p> <p>Once parameters have been loaded into the scanner from the backup restore feature there is no recovering the previously programmed settings.</p>
---	--

The Default feature (DEFAULT) restores all parameters to the factory default values. Factory default reset does not change the saved backup restore settings, override passwords, or edit parameters locked by a permanent non-resettable grand total. See Non-Resettable Grand Total, as described on page 73.

In the Backup menu, use the **Up** arrow key to select the desired menu. Press **Enter** to execute the save, load, or restore defaults command. To restore the scanner to factory defaults, press **Enter** again to confirm the request when Defaults? (DEFLTSP) is *blinking*.

Information (INFO)

The Information menu is part of the System features menu. It shows software identification number, version number, and extended model number. To view this information:





Go to the Information menu (INFO) and press **Enter** button.

Continue pressing **Enter** to scroll through the displays.

Following the information display, the scanner will exit the Advanced features menu and return to run mode.

OPERATION

Front Panel Buttons Operation

Symbol	Description
	<p>Hold the Menu through-glass button when in power save mode (display will show ) to awaken through-glass buttons.</p> <p>Press the Menu button to enter Programming Mode.</p> <p>Press the Menu button during Programming Mode to return to the previous menu selections.</p> <p>Hold the Menu button for 1.5 seconds at any time to exit Programming Mode and return to Run mode.</p> <p>Press and hold the Menu button for 3 seconds to access the Advanced features menu.</p>
	<p>Press Previous to manually display the previous PV or input display.</p> <p>Press the Right arrow button in programming mode to move to the next digit or decimal position.</p> <p>Press the Right arrow button in programming mode to go backward through most selection menus.</p>
	<p>Press Next to manually display the next PV or input display.</p> <p>Press the Up-arrow button in programming mode to scroll forward through the menus, decimal point, or to increment the value of a digit</p>
	<p>Press Scan to pause automatic scanning.</p> <p>Press Scan to resume automatic scanning when paused.</p> <p>Press the Enter button in programming mode to access a menu or to accept a setting.</p>

Note: The following through-glass button information is reprinted from Through-Glass Button Operation on page 22.

Through-Glass Button Operation

To actuate a button, press and remove one finger to the glass directly over the marked button area. Remove finger to at least 4 inches away from the glass in between button activations. Through-glass and mechanical buttons may be held to cycle through menus or digits in place of repeatedly pushing a button.



Through-Glass Power Save Mode (Decimal Display -2 Models Only)

Through-glass buttons enter a power saving mode after three minutes of inactivity. This mode is indicated by a power symbol (⏻) appearing in the lower right of the display. Only the **MENU** button is monitored in this mode. To activate the through-glass buttons, press and hold the menu button for up to five seconds. The display will read **AWAKE**, and the through-glass buttons will be fully enabled.

Through-Glass Disabled Mode

When the cover is removed, the four mechanical buttons located next to the sensors may be used. The sensors are disabled when a mechanical button is pressed and will automatically be re-enabled after 60 seconds of inactivity. The through-glass power symbol (⏻) will blink in the lower right of the display if the buttons are disabled due to a mechanical pushbutton being pressed.

Through-Glass Button Equalize Delay

The through-glass buttons are designed to constantly recalibrate for ambient conditions. When the cover position is changed, the cover is removed, or an object is removed that was placed over the front window, it may take a moment for the through-glass buttons to recalibrate to the change in conditions.

Allow up to 2 minutes for the through-glass buttons to recalibrate to new conditions in these cases where the cover position was changed, or the front window is being unblocked.



IMPORTANT

Through-glass buttons will not work if two or more buttons are detected as being pressed simultaneously. As a result, be careful to avoid triggering multiple buttons or reaching across one button location to press another.

Through-Glass Button Tips and Troubleshooting

The through-glass buttons are designed to filter normal levels of ambient interference and to protect against false triggering, however it is recommended that the through-glass buttons be turned off (slide THRU-GLASS BUTTONS switch to OFF) if there is an infrared interference source in line-of-sight to the display or if the buttons are not needed.

Through-Glass Button Tips:

- To the extent possible, install the display facing away from sunlight, windows, reflective objects and any sources of infrared interference.
- Keep the glass window clean.
- Tighten the cover securely.
- Use a password to prevent tampering.
- If the cover has not been installed and secured tightly, it may take a moment for the through-glass buttons to properly self-calibrate when the cover is tightened.

After all connections have been completed and verified, connect the ribbon cable to the display module, fasten the display module to the base, install enclosure cover, and then apply power.

Pause/Start Automatic Scanning

Automatic scanning will cycle through the enabled Modbus PVs, math channel CVs, rate, total, and grand total. The time each variable will be displayed is programmed in the *Scan Time (T--SCAN)* menu on page 51.

To pause scanning on the displayed variable, press the **Scan** button.

To start scanning again, press the **Scan** button.

Manual Scanning

The enabled Modbus PVs, math channel CVs, rate, total, and grand total variables can be manually cycled onto the display using the **Next** and **Previous** buttons.

The **Next** button will display the next enabled display variable, proceeding in the order of Modbus PVs, math channel CVs, rate, total, and grand total.

The **Previous** button will display the displayed variable shown prior to the one being displayed, cycling through display variable in the reverse order.

Resetting the Total (TOTAL?)

If manual total reset is enabled in the *Total Reset* menu, the total may be reset by holding the **Right** arrow button while the total is being displayed and using the **Enter** button to confirm the reset.

Additionally, if programmed for manual reset, the total may be reset using a normally open pushbutton connected across the terminals RST and COM.

*Note: The total is cleared immediately when **Enter** button is pressed. Totalization will then continue, even if the **Enter** button or external reset button continues to be held down/triggered.*

Resetting the Grand Total (Gr TOT?)

If manual grand total reset is enabled in the *Grand Total Reset* menu, the grand total may be reset by holding the **Right** arrow button while the grand total is being displayed and using the **Enter** button to confirm the reset.

*Note: The grand total is cleared immediately when **Enter** button is pressed. Totalization will then continue, even if the **Enter** button or external reset button continues to be held down/triggered.*

Reset Scanner to Factory Defaults

Reset to factory defaults will restore most scanner parameters to their factory default setting.

When the parameters have been changed in a way that is difficult to determine what's happening, it might be better to start the setup process from the factory defaults.

Factory default reset does not change the saved backup restore settings, override passwords, or edit parameters locked by a permanent non-resettable grand total. See Non-Resettable Grand Total, as described on page 73.

Instructions to load factory defaults can be found in the Backup & Restore (BACKUP) menu on page 80.

Factory Defaults & User Settings

The following table shows the factory setting for most of the programmable parameters on the scanner. Next to the factory setting, the user may record the new setting for the particular application.

Model: _____ S/N: _____ Date: _____

Parameter	Display ¹	Default Setting	User Setting & Notes
Mode	MODE	Master	
Modbus PV1	PV 1	Enable	
Slave ID	SLAVEID	1	
Function Code	FUNCODE	Function 03	
Register Number	REG NUM	40001	
Data Type	DATATYP	Float	
Byte	BYTE	1234	
Modbus PV2	PV 2	Enable	
Slave ID	SLAVEID	2	
Function Code	FUNCODE	Function 03	
Register Number	REG NUM	40001	
Data Type	DATATYP	Float	
Byte	BYTE	1234	
Modbus PV3	PV 3	Enable	
Slave ID	SLAVEID	3	
Function Code	FUNCODE	Function 03	
Register Number	REG NUM	40001	
Data Type	DATATYP	Float	
Byte	BYTE	1234	
Modbus PV4	PV 4	Enable	
Slave ID	SLAVEID	4	
Function Code	FUNCODE	Function 03	
Register Number	REG NUM	40001	
Data Type	DATATYP	Float	
Byte	BYTE	1234	
Modbus PV5-16	PV 5-16	Disable	
Poll Time	T POLL	2.0 seconds	
Modbus Timeout	TIMEOUT	0.2 seconds	
Retries to Error	RETRIES	3	
Setup	SETUP		
Display	DISPLAY		
Top Display (Decimal Display Models Only)	TOPDISP	PV	
Bottom Display	BOTDISP	Tag	
PV Setup	PVSETUP		
PV 1	PV 1		
Format (Decimal Display Models)	FORMAT	Top Display	
Format (Feet & Inches Display Models)	FORMAT	Ft-In-16	

Parameter	Display ¹	Default Setting	User Setting & Notes
Tag	TAG	PV 1	
Units	UNITS	FEET	
Display Decimal Point (Decimal Display Models Only)	DISPDP	1	
Float Decimal Point (Decimal Display Models Only)	FLOATDP	1	
Scale	SCALE	Factor	
Factor Decimal Point	FDP	3	
Factor Value	VALUE	1.000	
PV 2	PV 2		
Format (Decimal Display Models)	FORMAT	Top Display	
Format (Feet & Inches Display Models)	FORMAT	Ft-In-16	
Tag	TAG	PV 2	
Units	UNITS	FEET	
Float Decimal Point (Decimal Display Models Only)	FLOATDP	1	
Display Decimal Point (Decimal Display Models Only)	DISPDP	1	
Scale	SCALE	Factor	
Factor Decimal Point	FDP	3	
Factor Value	VALUE	1.000	
PV 3	PV 3		
Format (Decimal Display Models)	FORMAT	Top Display	
Format (Feet & Inches Display Models)	FORMAT	Ft-In-16	
Tag	TAG	PV 3	
Units	UNITS	FEET	
Float Decimal Point (Decimal Display Models Only)	FLOATDP	1	
Display Decimal Point (Decimal Display Models Only)	DISPDP	1	
Scale	SCALE	Factor	
Factor Decimal Point	FDP	3	
Factor Value	VALUE	1.000	
PV 4	PV 4		
Format (Decimal Display Models)	FORMAT	Top Display	
Format (Feet & Inches Display Models)	FORMAT	Ft-In-16	
Tag	TAG	PV 4	
Units	UNITS	FEET	
Float Decimal Point (Decimal Display Models Only)	FLOATDP	1	

Parameter	Display ¹	Default Setting	User Setting & Notes
Display Decimal Point (Decimal Display Models Only)	DISPDP	1	
Scale	SCALE	Factor	
Factor Decimal Point	FDP	3	
Factor Value	VALUE	1.000	
Math Channel Setup	MATH		
CV 1	CV 1		
Format	FORMAT	Off	
CV 2	CV 2		
Format	FORMAT	Off	
CV 3	CV 3		
Format	FORMAT	Off	
CV 4	CV 4		
Format	FORMAT	Off	
Rate Display Setup	RATE	Off	
Tag	TAG	Rate	
Time Base	T BASE	Sec	
Rate Units	RATE U	Gallons/Sec	
Rate Decimal Point (Decimal Display Models Only)	RATEDP	0	
Total Display Setup	TOTAL	Off	
Total Units	TOT U	Gallons	
Total Multiplier		X1	
Total Decimal Point (Decimal Display Models Only)	GTOTALDP	0	
Grand Total Display Setup	TOTAL	Off	
Grand Total Units	TOT U	Gallons	
Grand Total Multiplier		X1	
Grand Total Decimal Point (Decimal Display Models Only)	TOTALDP	0	
Tag Display Time	T-TAG	2 seconds	
Units Display Time	T-UNITS	2 seconds	
Scan Time	T-SCAN	2 seconds	
Pulse Input Setup	PULSEIN	Active	
K-Factor Setup	KFACTOR		
K-Factor Unit	F-UNIT	Gallons	
K-Factor Decimal Point	KFDP	4	
K-Factor	KFACTOR	1.0000	
Communications	COMM		
Scanner Modbus ID	SCAN ID	240	
Baud Rate	BAUD	9600 bps	
Transmit Delay	TX DELAY	50 ms	
Parity	PARITY	Even	
Advanced Features	ADVANCE		
Open Collector Output	OUTPUT		



Parameter	Display ¹	Default Setting	User Setting & Notes
Output 1	OUT 1	Off	
Output 2	OUT 2	Off	
Analog Output	ROUT		
Source	SOURCE	Disable	
Math Functions	MATH		
Channel 1	CV 1	Multiply	
Parameter 1	PAR 1	PV 1	
Parameter 2	PAR 2	Rate	
Channel 2	CV	Multiply	
Parameter 1	PAR 1	PV 1	
Parameter 2	PAR 2	Total	
Channel 3	CV 3	Sum	
Parameter 1	PAR 1	PV 1	
Parameter 2	PAR 2	PV 2	
Channel 4	CV 4	Multiply	
Parameter 1	PAR 1	PV 2	
Parameter 2	PAR 2	PV 3	
Gate	GATE		
Low Gate	LO GATE	1	
High Gate	HI GATE	2	
Filter	FILTER	High	
Low Flow Cutoff	CUTOFF	0 (Disabled)	
Total Reset	T RESET		
Total Reset	TOTAL	Manual - Enabled	
Grand Total Reset	GT RESET	Manual - Enabled	
Password	PASSWORD		
Parameter Lock Password	PASS	00000 (unlocked)	
Total Reset Password	PASS T	00000 (unlocked)	
Grand Total Reset Password	PASS GT	00000 (unlocked)	
Additional Parameters & Notes			

1. Feet and Inches display models do not include lower display decimal points.

TROUBLESHOOTING

Due to the many features and functions of the meter, it's possible that the setup of the meter does not agree with what an operator expects to see. If the meter is not working as expected, refer to the *Diagnostics* menu and consult the recommendations described below.

Troubleshooting Tips

Symptom	Check/Action
No display or faint display	Check power connection. Press and hold Menu key for 5 seconds to check for Standby mode. If "WAKEUP" is displayed, press the Enter key to awaken the scanner from Standby mode.
Through-glass buttons do not respond	If  is displayed, hold Menu through-glass button to leave power save mode. If  is flashing, wait 60 seconds to leave mechanical pushbutton lockout mode. If the cover was recently tightly secured, you may need to wait up to 2 minutes for buttons to self-calibrate to the new cover position due to glass reflection. Verify Through-Glass Button switch on display module is in ON position. Sunlight can interfere with the sensors. It is recommended to shield the window while operating the buttons by standing so as to block direct sunlight.
Scanner channel display NONE	Verify that the polling parameters (slave address, register, etc) are correct. If the channel is a math channel CV, verify the chosen math function does not include any NONE selections or un-programmed Modbus PVs.
Long time between channel value updates	Verify all channels are communicating. Errors, combined with long timeouts and high allowable number of failures when polling Modbus devices, will combine to significantly delay the polling speed. Reduce the number of allowable timeout errors to check that communications are successful, and if there are errors, reduce the timeout if possible.
Rate display unsteady	Increase low gate setting in <i>Advanced</i> menu.
Scanner displays span error message during scaling	Verify minimum input span requirements
Scanner flashes maximum display	Check slave device registers are valid. Check math channels are not exceeding maximum possible display. Check input signal is within scaled range of 99999.
Rate display response is too slow	Check if gate settings can be lowered.
If the display locks up or the scanner does not respond	Perform hard reset by removing the display module or by removing DC power.
Backlight does not appear.	Backlight is intended for viewing assistance in dim lighting. It may not be noticeable under good lighting conditions. Battery powered models turn off the backlight after ten seconds of button inactivity.
Other symptoms	Call Technical Support for assistance.

Note: Certain sequences of events can cause unexpected results. To solve these issues, it is best to start fresh from factory defaults and map changes ahead of time, rather than at random.

MOUNTING DIMENSIONS

All units: inches [mm]

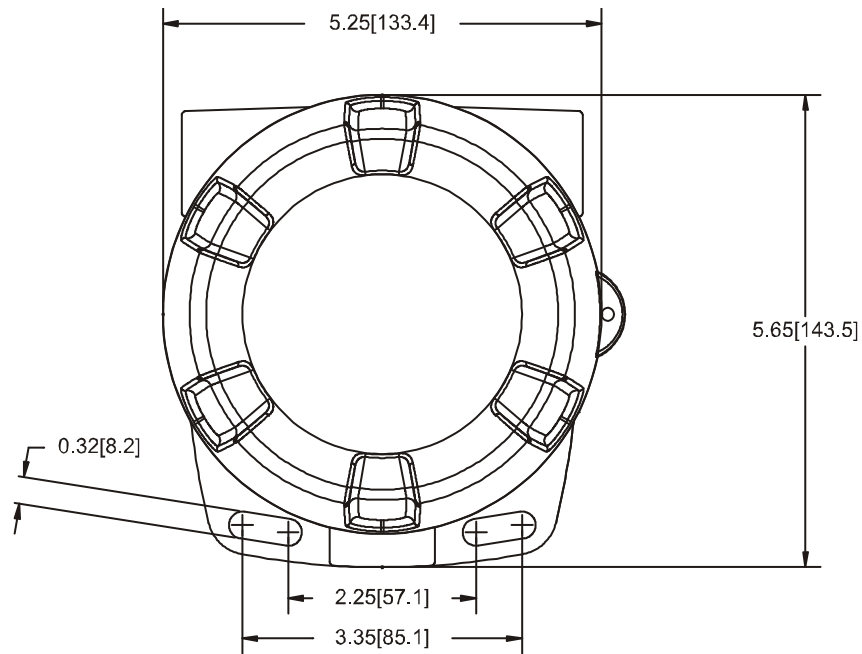

Figure 15: Enclosure Dimensions – Front View

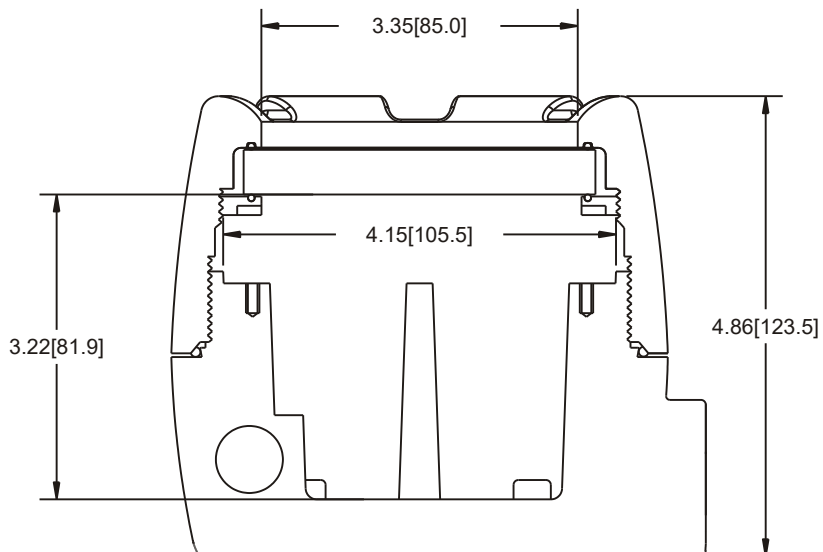

Figure 16: Enclosure Dimensions – Side Cross Section View

QUICK USER INTERFACE REFERENCE

Pushbutton	Function
MENU	Go to Main menu. Back out one level of programming. Hold to enter Advanced menu.
▶ (Right) / PREV	Return to previous display variable. Move to next digit or decimal point position. Hold when displaying total or grand total to reset the total or grand total. Return to previous same-level programming menu.
▲ (Up) / NEXT	Display next display variable. Move to next selection or increment digit. Enter grand total/max/min display mode.
↻ (Enter) / SCAN	Pause/start automatic display scanning. Accept selection/value and move to next selection. Acknowledge Alarm.



EU DECLARATION OF CONFORMITY

Issued in accordance with ISO/IEC 17050-1:2004 and ATEX Directive 2014/34/EU.

We,

Precision Digital Corporation
233 South Street
Hopkinton, MA 01748 USA

as the manufacturer, declare under our sole responsibility that the product(s),

Model PD6830X Modbus Scanner & Rate/Totalizer

to which this declaration relates, is in conformity with the European Union Directives shown below:

2014/35/EU	Low Voltage Directive
2014/34/EU	ATEX Directive
2014/30/EU	EMC Directive
2011/65/EU	RoHS Directive

This conformity is based on compliance with the application of harmonized or applicable technical standards and, when applicable or required, a European Union notified body certification.

Standards:

EN 55022:2007	EN 61000-6-2:2005	EN 60079-0:2009	EN 61000-6-4:2004
EN 60079-1:2007	EN 61010-1:2001	EN 60079-31:2009	EN 61326:2006

The standards EN 55022:2007, EN 60079-0:2009, EN 60079-1:2007, EN 60079-31:2009, EN 61000-6-4:2004, EN 61010-1:2001, and EN 61326:2006 are no longer harmonized. The requirements of these standards have been checked against the harmonized standard EN 55022:2010, EN 60079-0:2012+A11:2013, EN 60079-1:2014, EN 60079-31:2014, EN 61000-6-4:2007+A1:2011, EN 61010-1:2010, and EN 61326:2013 and there were no major technical changes affecting the latest technical knowledge for the products listed above.

EC Type Examination Certificate: Sira 10ATEX1116X

Product Markings:

 II 2 G D
Ex d IIC T6 Gb
Ex tb IIIC T85°C Db IP68
Tamb = -40°C to +75°C

ATEX Notified Body for EC Type Examination Certificate: Sira Certification Service, NB 0518
Unit 6, Hawarden Industrial Park
Hawarden, Deeside, CH5 3US, UK

ATEX Quality Assurance Notification No.: SIRA 10 ATEX M462

ATEX Notified Body for Quality Assurance: Sira Certification Service, NB 0518
Unit 6, Hawarden Industrial Park
Hawarden, Deeside, CH5 3US, UK

Signed for and on behalf of Precision Digital Corporation:



Name: Jeffrey Peters
Company: Precision Digital Corporation
Title: President
Date: 02/12/2018

Document No: DoC PD6830X {021218}



TEKMATION LLC reserves the right to change the designs and/or materials of its products without notice. The contents of this publication are the property of TEKMATON and cannot be reproduced by any other party without written permission. All rights reserved. Copyright © 2016 TEKMATON, LLC
DOC#TEK/TPS/MNL/78048/240520/01
TEKMATION LLC



www.tek-trol.com

Tek-Trol is a fully owned subsidiary of TEKMATON LLC. We offer our customers a comprehensive range of products and solutions for process, power and oil & gas industries. Tek-Trol provides process measurement and control products for Flow, Level, Temperature & Pressure Measurement, Control Valves & Analyzer systems. We are present in 15 locations globally and are known for our knowledge, innovative solutions, reliable products and global presence.

Tek-Trol LLC

796 Tek Drive Crystal Lake, IL 60014 USA
Tel.: +1 847 857 6076 Fax: +1 847 655 6147
Email: tektrol@tek-trol.com
www.tek-trol.com