



Tek-LCD 7805B

Explosion-Proof Large Display Loop-Powered Indicator

Instruction Manual

Document Number: IM-7805B



www.tek-trol.com

NOTICE

Read this manual before working with the product. For personal and system safety, and for optimum product performance, make sure you thoroughly understand the contents before installing, using, or maintaining this product.

For technical assistance, contact

Customer Support

796 Tek-Drive

Crystal Lake, IL 60014

USA

Tel: +1 847 857 6076, +1 847 655 7428

© COPYRIGHT Tek-Trol LLC 2016

No part of this publication may be copied or distributed, transmitted, transcribed, stored in a retrieval system, or translated into any human or computer language, in any form or by any means, electronic, mechanical, manual, or otherwise, or disclosed to third parties without the express written permission. The information contained in this manual is subject to change without notice.

Table of Contents

1	Safety Instructions	3
1.1	Installation	3
1.2	Unpacking	3
1.3	Pre-Installed Conduit Plug	4
1.4	Mounting	4
1.5	Cover Jam Screw	4
1.6	Connections	4
1.7	Connections & Wiring Diagrams	5
2	SETUP	7
2.1	Overview	7
2.2	Scaling Controls and Display	7
3	Setting Up the Meter	8
3.1	Calibrating the Meter	8
3.2	Minimum & Maximum Input Span	8
3.3	Setting the Decimal Point	8
3.4	Factory Defaults & User Settings	8
4	TROUBLESHOOTING	9
4.1	Troubleshooting Tips	9
5	MOUNTING DIMENSIONS	10
6	ORDERING INFORMATION	11
6.1	Accessories	11
7	SPECIFICATIONS	11
7.1	Product Ratings and Approvals	12
7.2	Electromagnetic Compatibility	13

Disclaimer

The information contained in this document is subject to change without notice. Tek-Trol makes no representations or warranties with respect to the contents hereof; and specifically disclaims any implied warranties of merchantability or fitness for a particular purpose



WARNING

-
- This product is not recommended for life support applications or applications where malfunctioning could result in personal injury or property loss. Anyone using this product for such applications does so at his/her own risk. Tek-Trol LLC shall not be held liable for damages resulting from such improper use.
 - Failure to follow installation guidelines could result in death or serious injury. Make sure only qualified personnel perform the installation.
 - Never remove the meter cover in explosive environments when the circuit is live.
 - Cover must be fully engaged to meet flameproof/explosionproof requirements.
-



CAUTION

Read complete instructions prior to installation and operation of the meter.

Limited Warranty

Tek-Trol LLC warrants this product against defects in material or workmanship for the specified period under "Specifications" from the date of shipment from the factory.

Tek-Trol's liability under this limited warranty shall not exceed the purchase value, repair, or replacement of the defective unit.

Registered Trademarks

All trademarks mentioned in this document are the property of their respective owners.

1 SAFETY INSTRUCTIONS



WARNING

- Read complete instructions prior to installation and operation of the meter.
 - Installation and service should be performed only by trained service personnel. Service requiring replacement of internal components must be performed at the factory.
 - Disconnect from supply before opening enclosure. Keep cover tight while circuits are alive. Conduit seals must be installed within 18" (147ft) of the enclosure.
 - Verify that the operating atmosphere of the meter is consistent with the appropriate hazardous locations certifications.
 - If the meter is installed in a high voltage environment and a fault or installation error occurs, high voltage may be present on any lead
-

1.1 Installation



WARNING

disconnect from supply before opening enclosure. Keep cover tight while circuits are alive. Conduit seals must be installed within 18" (147ft) of the enclosure.

For Installation in USA: The Tek-LCD 7805B must be installed in accordance with the National Electrical Code (NEC) NFPA 70.

For Installation in Canada: Install in accordance with applicable local and national regulations (e.g. NEC). The Tek-LCD 7805B must be installed in accordance with the Canadian Electrical Code CSA 22.1. All input circuits must be derived from a CSA approved Class 2 source.

For European Community: The Tek-LCD 7805B must be installed in accordance with the ATEX directive 94/9/EC and the product certificate Sira 10ATEX116X. All controls and wiring connectors are accessed by opening the enclosure. To access electrical connectors, remove the 2 captive screws and remove the display module from the enclosure.

1.2 Unpacking

Remove the meter from box. Inspect the packaging and contents for damage. Report damages, if any, to the carrier.

If any part is missing or the meter malfunctions, please contact your supplier or the factory for assistance.

1.3 Pre-Installed Conduit Plug

The Tek-LCD 7805B is supplied with one pre-installed optional conduit plug for installations that do not require the use of both conduit entries. The conduit plug includes an internal hexagonal socket recess for removal. The pre-installed plug and installation is included in all hazardous area approvals of the Tek-LCD 7805B.



WARNING

installations of the supplied conduit plug require the application of non-setting (solvent free) thread sealant. If the pre-installed conduit.

Plug is removed or replaced all relevant hazardous area guidelines must be followed for its installation or replacement conduit.

1.4 Mounting

The Tek-LCD 7805B has two slotted mounting flanges that may be used for pipe mounting or wall mounting. Alternatively, the unit may be supported by the conduit using the conduit holes provided.



WARNING

Do not attempt to loosen or remove flange bolts while the meter is in service.

1.5 Cover Jam Screw

The cover jam screw should be properly installed once the meter has been wired and tested in a safe environment. The cover jam screw is intended to prevent the removal of the meter cover in a flameproof environment without the use of tools. Using a M2 hex wrench, turn the screw clockwise until the screw contacts the meter. Turn the screw an additional 1/4 to 1/2 turn to secure the cover. Caution: Excess torque may damage the threads and/or wrench.

1.6 Connections



WARNING

-
- Static electricity can damage sensitive components.
 - Observe safe handling precautions for static-sensitive components.
 - Use proper grounding procedures/codes.
 - If the meter is installed in a high voltage environment and a fault or installation error occurs, high voltage may be present on any lead or terminal.
-

To access the connectors, remove the enclosure cover and unscrew the two captive screws that fasten the display module. Remove the display module. Signal connections are made to a three-terminal connector on the rear of the display module. Grounding connections are made to the two ground screws provided on the base – one internal and one external.

S+ 4-20 mA signal input positive terminal connection

S- 4-20 mA signal return/negative terminal connection

B- 4-20 mA signal return/negative terminal when using the installed loop powered backlight option.

Refer to Figure 1 for terminal positions.



WARNING

Observe all safety regulations. Electrical wiring should be performed in accordance with all agency requirements and applicable national, state, and local codes to prevent damage to **WARNING** the meter and ensure personnel safety.

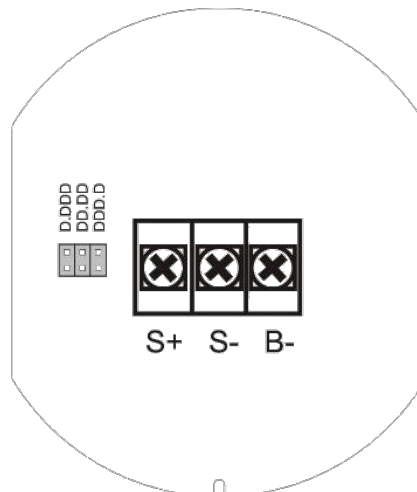

Figure 1. Tek-LCD 7805B Connectors

1.7 Connections & Wiring Diagrams

Signal connections are made to a three-terminal connector mounted on the rear of the display module. The enclosure also provides one internal and one external earth grounding screw. The 4-20 mA input with no backlight has a maximum voltage drop of 1 V and is wired as shown in Figure 2. The loop-powered backlight configuration requires a total maximum voltage drop of 4 V. The backlight option is recommended for dim lighting conditions and is enabled when wired as shown in Figure 3.

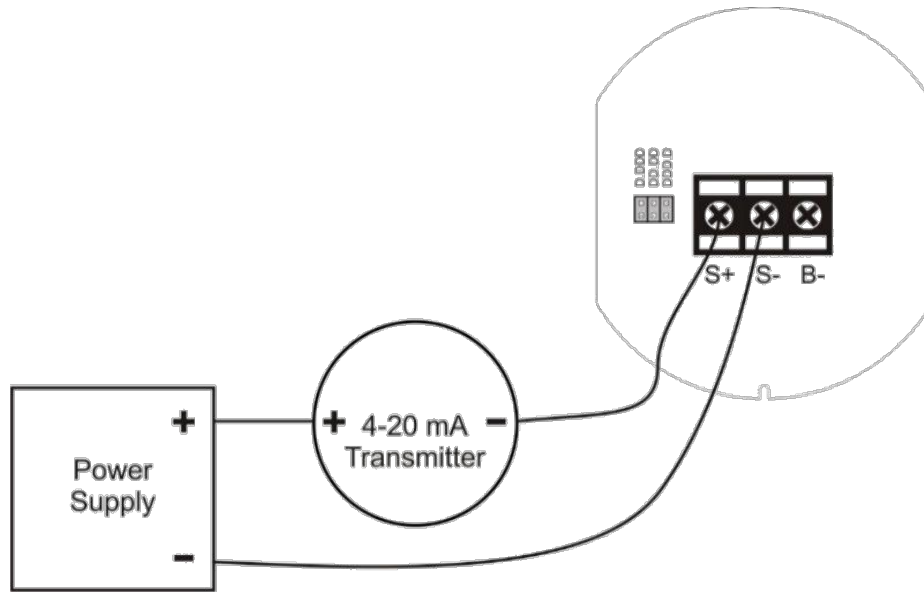

Figure 2. Tek-LCD 7805B Input Connections without Backlight

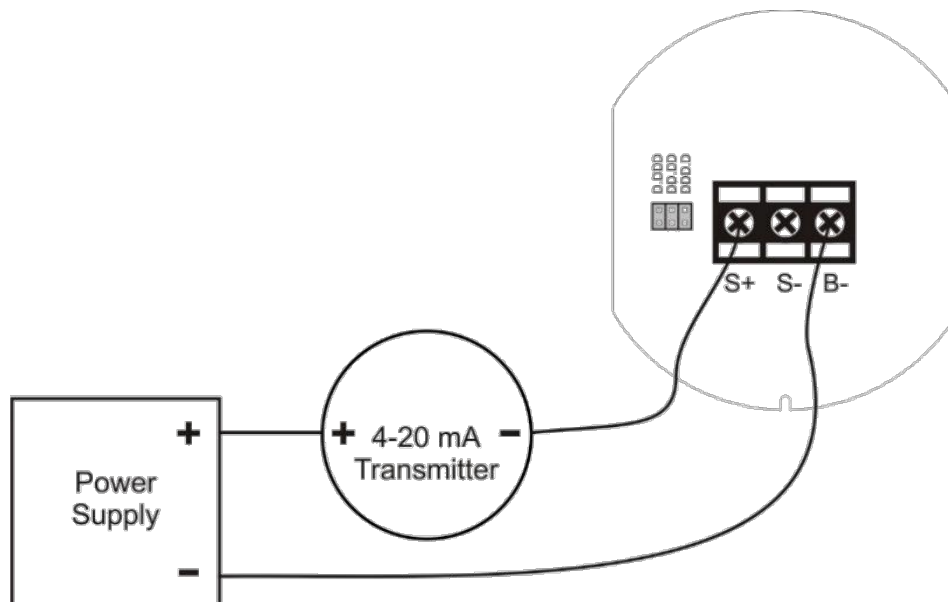

Figure 3. Tek-LCD 7805B Input Connections with Loop-Powered Backlight

2 SETUP

2.1 Overview

Setup is done using four rotary control dials located on the front of the display module that are accessed when the meter cover is removed. Setup is performed using a 4-20 mA signal source and scaling the 4 and 20 mA readings using the control dials.

2.2 Scaling Controls and Display



Control	Description
LO	4 mA display adjust.
LO FINE	4 mA precision display adjust.
HI	20 mA display adjust.
HI FINE	20 mA precision display adjust.

3 SETTING UP THE METER

3.1 Calibrating the Meter

The meter is provided factory calibrated to display -50.0 at 4 mA and 150.0 at 20 mA. HI and LO coarse and fine controls are labeled on the front of the display. Use the HI and LO controls for large range changes during calibration and the HI FINE and LO FINE controls for precision changes.

Apply a 4 mA signal and adjust the LO controls to display the desired reading. Apply a signal between 16 and 20 mA and adjust the HI controls to display the desired reading. Complete the calibration procedure by making minor adjustments to the LO and HI controls as necessary.

3.2 Minimum & Maximum Input Span

A minimum input span of 20 counts is required between a 4 mA and 20 mA input. A maximum input span of 2000 counts may be setup between a 4 mA and 20 mA input. The meter will not properly calibrate or display if these minimum and maximum span ranges are not maintained during scaling.

3.3 Setting the Decimal Point

Decimal point may be set using a three position jumper on the rear of the display module. To access the connectors, unscrew the two captive screws that fasten the display module. Remove the display module and place the jumper on the desired pins as indicated on the board for decimal point locations of D.DDD, DD.DD, DDD.D, or remove it if no decimal point is desired.

3.4 Factory Defaults & User Settings

The following table shows the factory setting for most of the programmable parameters on the meter. Next to the factory setting, the user may record the new setting for the particular application.

Model: _____ S/N: _____ Date: _____

Parameter	Default Setting	User Setting
<i>Decimal point</i>	<i>1 place</i>	
<i>Calibration Settings</i>		
<i>Input 1</i>	<i>4.00 mA</i>	
<i>Display 1</i>	<i>-50.0</i>	
<i>Input 2</i>	<i>20.00 mA</i>	
<i>Display 2</i>	<i>150.0</i>	

4 TROUBLESHOOTING

The rugged design and the user-friendly interface of the meter should make it unusual for the installer or operator to refer to this section of the manual. If the meter is not working as expected, refer to the recommendations below.

4.1 Troubleshooting Tips

Symptom	Check/Action
No display	Check input signal connections.
Rate display unsteady during calibration	Adjust LO FINE or HI FINE controls to fine-tune the display.
Meter displays 1 on the left most digit location	Check signal level is not over range. Dial down the HI control and re-calibrate at 20 mA.
Display is faded	Check input signal is not under 1 mA.
If the display locks up or the meter does not respond at all	Perform hard reset by shorting S+ and S- terminals.
Backlight does not appear	Verify backlight is installed. Check signal connections are as shown in Figure 3.
Other symptoms not described above	Call Technical Support for assistance.

5 MOUNTING DIMENSIONS

All units: inches [ft]

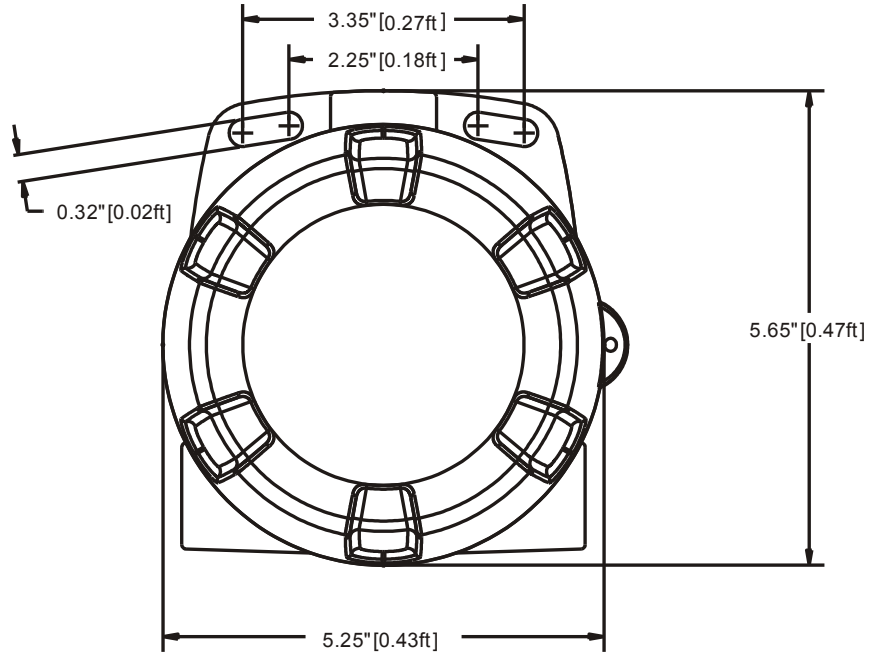

Figure 4. Enclosure Dimensions – Front View

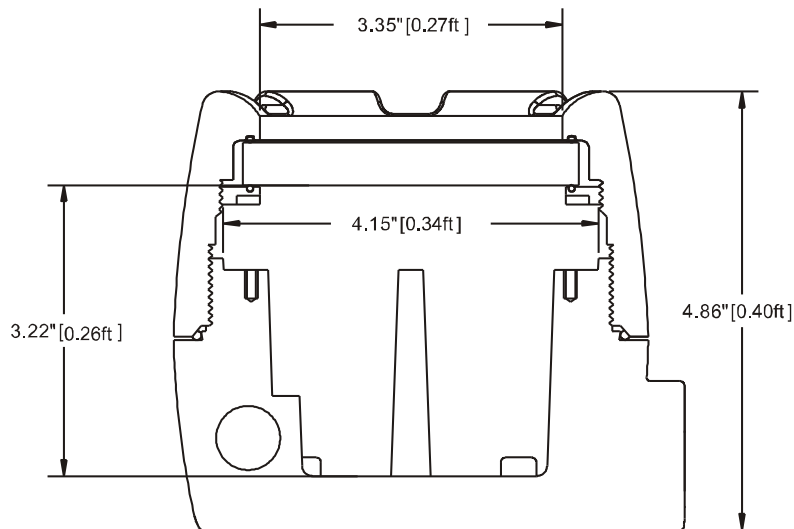

Figure 5. Enclosure Dimensions – Side Cross Section View

Note: The supplied conduit plug may extend up to 0.6 in [0.04ft] from the conduit opening when installed.

6 ORDERING INFORMATION

Model Number	Reorder Number	Description
PD6870-0L0-TK	Tek-LCD 7805B-0L0	Tek-LCD 7805B-0L0

6.1 Accessories

Model Number	Reorder Number	Description
PDA0002-TK	Tek-LCD 7800B-002	3/4" M-NPT to 1/2" F-NPT Approved Reducer
PDA6846-TK	Tek-LCD 7800A-6846	Steel Pipe Mounting Kit
PDA6846-SS-TK	Tek-LCD 7800A-6846SS	Stainless Steel Pipe Mounting Kit

7 SPECIFICATIONS

Except where noted all specifications apply to operation at +25°C.

General	
DISPLAY	3 ½ digit LCD 1" (0.08ft); -1999 to 1999
DISPLAY UPDATE RATE	2.5 Updates/Second
OVERRANGE	Display reads 1 on the left most digit
PROGRAMMING METHOD	Four front mounted rotary control dials accessed when the cover is removed.
RECALIBRATION	Recalibration is recommended at least every 12 months.
NORMAL MODE REJECTION	60 dB rejection ratio
ENVIRONMENTAL	Operating temperature range: -40 to 75°C (-40°F to 167°F) Storage temperature range: -40 to 75°C (-40°F to 167°F) Relative humidity: 0 to 90% non-condensing
CONNECTIONS	Screw terminals accept 12 to 22 AWG wire
ENCLOSURE	Explosion-proof die cast aluminum with glass window, 0.30% max copper content, corrosion resistant epoxy coating, color: blue. NEMA 4X, IP68. Two ¾" NPT threaded conduit openings. One ¾" NPT nickel plated brass conduit plug with 0.03ft hex key fitting installed.

MOUNTING	May be mounted directly to conduit. Two slotted flanges for wall mounting or NPS 1½" to 2½" or DN 40 to 0.21ft pipe mounting.
OVERALL DIMENSIONS	5.65" x 5.25" x 4.86" (0.47ft x 0.43ft x) (W x H x D)
WEIGHT	5.00 lbs (80 oz, 2.27 kg)
WARRANTY	3 years parts and labor

INPUT		
ACCURACY	±0.1% of full span ±1 count	
TEMPERATURE DRIFT	150 PPM/°C (302PPM°F) from -40 to 75°C (-40°F to 167°F) ambient	
DECIMAL POINT	User selectable decimal point	
CALIBRATION RANGE	4 mA input: -1000 to +1000; 20 mA between 20 and 2000 counts greater than 4 mA display. Two-point linear display span.	
MAXIMUM VOLTAGE DROP	Without Backlight	With Loop-Powered Backlight
	1 VDC @ 20 mA	4 VDC @ 20 mA
EQUIVALENT RESISTANCE	50 Ω @ 20 mA	200 Ω @ 20 mA
INPUT OVERLOAD	Over current protection to 2 A max.	
HART TRANSPARENCY	Analog input will not interfere with existing HART communications on the wired 4-20 mA signal	

7.1 Product Ratings and Approvals

FM	The Top display is assigned to rate or total. The Bottom display is programmable to display total; total and units; total and tag; total, total units, and rate units; grand total; grand total and grand total units; grand total and tag; grand total, grand total units, and rate units; rate units; rate; rate and total units; rate and rate units; rate and tag; rate units; total units; a custom tag; or be off (blank).
ATEX	II 2 G D Ex d IIC T6 Gb Ex tb IIIC T85°C Db IP68 Ta = -40°C to +75°C (-40°F to 167°F)

	ATEX Certificate: Sira 10ATEX1116X
CSA	Class I, Division 1, Groups B, C, D Class II, Division 1, Groups E, F, G Class III, Division 1; T6 Class I, Zone 1, Ex d IIC T6 Ta = -40°C to +75°C (-40°F to 167°F) Enclosure: Type 4X & IP66 Certificate number: 11 2325749
IECEX	IECEX SIR 10.0056X Ex d IIC T6 Gb Ex tb IIIC T85°C Db IP68 Ta = -40°C to +75°C (-40°F to 167°F)

Special Conditions for Safe Use:

Use suitably certified and dimensioned cable entry device and/or plug. The equipment shall be installed such that the supply cable is protected from mechanical damage. The cable shall not be subjected to tension or torque. If the cable is to be terminated within an explosive atmosphere, then appropriate protection of the free end of the cable shall be provided.

Year of Construction

This information is contained within the serial number with the first four digits representing the year and month in the YYMM format.

For European Community: The Tek-LCD 7805B must be installed in accordance with the ATEX directive 94/9/EC, and the product certificate Sira 10ATEX1116X.

7.2 Electromagnetic Compatibility

EMISSIONS	EN 61326:2013 Safety requirements for measurement, control, and laboratory use – Industrial Group 1 Class A ISM emissions requirements
Radiated Emissions	Class A
IMMUNITY	EN 61326:2013 Safety requirements for measurement, control, and laboratory use
ESD	±4 kV contact, ±8 kV air

RFI – Amplitude Modulated	80-1000 MHz @ 10 V/m, 1.4-2.0 GHz @ 3 V/m, 2.0-2.7 GHz @ 1 V/m, 80% AM (1 kHz)
EFT	±2 kV DC mains, ±1 kV other
Telco Surge	±1 kV
CRFI	3 V, 0.15-80 MHz, 1 kHz 80% AM



TEKMATION LLC reserves the right to change the designs and/or materials of its products without notice. The contents of this publication are the property of TEKMATON and cannot be reproduced by any other party without written permission. All rights reserved. Copyright © 2016 TEKMATON LLC
DOC#TEK/ITPS/MNL/7805B/2405/01.1
TEKMATION LLC



www.tek-trol.com

Tek-Trol is a fully owned subsidiary of TEKMATON LLC. We offer our customers a comprehensive range of products and solutions for process, power and oil & gas industries. Tek-Trol provides process measurement and control products for Flow, Level, Temperature & Pressure Measurement, Control Valves & Analyzer systems. We are present in 15 locations globally and are known for our knowledge, innovative solutions, reliable products and global presence.

Tek-Trol LLC

796 Tek Drive Crystal Lake, IL 60014 USA
Tel.: +1 847 857 6076 Fax: +1 847 655 6147
Email: tektrol@tek-trol.com
www.tek-trol.com