



TEK-Batch 7900A

Analog Batch Controller

Instruction Manual

Document Number: IM-7900A



www.tek-trol.com

NOTICE

Read this manual before working with the product. For personal and system safety, and for optimum product performance, make sure you thoroughly understand the contents before installing, using, or maintaining this product.

For technical assistance, contact

Customer Support

796 Tek-Drive

Crystal Lake, IL 60014

USA

Tel: +1 847 857 6076, +1 847 655 7428

© **COPYRIGHT Tek-Trol LLC 2018**

No part of this publication may be copied or distributed, transmitted, transcribed, stored in a retrieval system, or translated into any human or computer language, in any form or by any means, electronic, mechanical, manual, or otherwise, or disclosed to third parties without the express written permission. The information contained in this manual is subject to change without notice.

Table of Contents

Table of Contents	3
Table of Figures	4
Introduction	4
Specifications	6
General	6
Process Input	6
Batch Controller Rate/Totalizer Display	7
Relays	7
Isolated 4-20 mA Transmitter Output	8
Serial Communications	8
Digital Inputs & Outputs	8
MeterView Pro	8
Product Ratings and Approvals;	9
Compliance Information	10
Safety	10
Electromagnetic Compatibility	10
Safety Information	11
Installation	11
Unpacking	11
Pre-Installed Conduit/Stopping Plug	12
Mounting	12
Cover Jam Screw	12
Transmitter Supply Voltage Selection (P+, P-)	12
Connections	13
Required & Factory Wired Connection	13
Connectors Labeling	14
Power Connections	14
Signal Connections	15
Serial Communications Connections	16
Three Wire Connections	16
Using PROVU Serial Adapters	18
Relay Connections	19
Switching Inductive Loads	19
F4 Digital Input Connections	20
4-20 mA Output Connections	20
Analog Output Transmitter Power Supply	20
Interlock Relay Feature	20
Digital I/O Connections	21
External Switch Contacts	21
Basic Operation and Programming	22
SafeTouch® Buttons	22
Front Buttons and Status LED Indicators	23
Controller Operation	24
Batch Control Operation Example	25
MeterView® Pro Software	27
MeterView Pro Installation	27
Display Functions and Messages	28
Setting Numeric Values	30
Setting Up the Batch Controller (setup)	31
Scaling and Calibration	32
Setting the Input Signal (Input)	32
Setting the Totalizer and Batching Features (total)	32
Setting the Input Units or Custom Tags (units)	32
Setting the Decimal Point (dEc pt)	32
Programming the Batch Controller (prog)	33
Input Calibration Method (InCAL)	33
Scaling the Controller (SCALE)	34
Time Base, Total Conversion Factor & Total Reset	35
Batch Start Mode (mode)	35
Calibrating the Controller with External Source (Cal)	35
Setting the Display Parameter & Intensity (display)	36
Setting the Relay Operation (relay)	37
Relay Assignment (Assign)	38
Setting the Relay Action	38
Setting Batch Control Relays	38
Programming Alarm Set and Reset Points	39
Setting Fail-Safe Operation	39
Programming Time Delay	39
Relay Action for Loss of 4-20 mA Input (Loop Break)	39
Relay Operation Details	40
Overview	40
Relays Initialization	40
Fail-Safe Operation	40
Front Panel LEDs	40
Automatic Reset (Auto)	41
Pump Alternation Control	41
Setting Up the Interlock Relay (Force On) Feature	41
Sample Relay Operation	42
Relay and Alarm Operation Diagrams	42
High Alarm Operation (Set > Reset)	42
Low Alarm Operation (Set < Reset)	42
High Alarm with Fail-Safe Operation (Set > Reset)	42
Low Alarm with Fail-Safe Operation (Set < Reset)	42
Rate Relay Sampling Operation	43
Total Relay Sampling Operation	43
Signal Loss or Loop Break Relay Operation	43
Time Delay Operation	44
Scaling the 4-20 mA Analog Output (Aout)	44
Reset Menu (reset)	45
Control Menu (ContI)	45
Setting Up the Password (pass)	45
Protecting or Locking the Controller	45
Grand Total Reset Password & Non-Resettable Total	46
Making Changes to a Password Protected Controller	46
Disabling Password Protection	46
Advanced Operation and Programming	47
Advanced Features Menu & Display Messages	48
Function Keys Operation	50
F4 Operation	50
Advanced Setup and Calibration	50
Multi-Point Calibration & Scaling	50
Maximum/Minimum Readings	50
Noise Filter (filter)	51
Noise Filter Bypass (bypass)	51
Rounding Feature (round)	51
Modbus RTU Serial Communications (serial)	51

Serial Communications Overview	52	Diagnostics Menu (diag)	57
Select Menu (SElEct)	53	Determining Software Version	57
Signal Conditioning Selection (Functn)	53	Reset Controller to Factory Defaults	57
Low-Flow Cutoff (Cutoff)	53	Factory Defaults & User Settings.....	58
Total and Grand Total Count Direction (Count)	54	Troubleshooting Tips	59
Analog Output Programming (AoutPr)	54	Service	60
Programmable Function Keys User Menu (user)	55	Mounting Dimensions	61
Internal Source Calibration (ICAL)	56	EU Declaration of Conformity	63
Troubleshooting.....	57		

Table of Figures

Figure 1: Transmitter Supply Voltage Selection	12	Figure 11: RS-485 Two-Wire Multi-Drop Wiring.....	18
Figure 2: Integrated ProVu Required Connections ..	13	Figure 12: Relay Connections	19
Figure 3: Connector Labeling for Fully Loaded PD8-6210	14	Figure 13: AC and DC Loads Protection.....	19
Figure 4: Power Connections.....	14	Figure 14: Low Voltage DC Loads Protection	19
Figure 5: Transmitters Powered by Internal Supply	15	Figure 15: F4 Digital Input Connections	20
Figure 6: Transmitter Powered by Ext. Supply or Self-Powered	15	Figure 16: 4-20 mA Output Connections	20
Figure 7: Voltage Input Connections	15	Figure 17: Interlock Connection	20
Figure 8: ProtEX-MAX Connections to a Serial Converter	16	Figure 18: Digital I/O Connections	21
Figure 9: Three-Wire RS485 Connection	16	Figure 19: General Four-Wire Network Connection..	52
Figure 10: RS-485 Wiring	17	Figure 20: General Two-Wire Network Connection..	52
		Figure 21: Enclosure Dimensions – Front View	61
		Figure 22: Enclosure Dimensions – Side Cross Section View.....	61

Disclaimer

The information contained in this document is subject to change without notice. Tek-Trol Technology Solutions makes no representations or warranties with respect to the contents hereof; and specifically disclaims any implied warranties of merchantability or fitness for a particular purpose.

	CAUTION: <i>Read complete instructions prior to installation and operation of the controller.</i>	WARNING: <i>Risk of electric shock or personal injury.</i>
---	--	---

 Warning!	<ul style="list-style-type: none">• <i>This product is not recommended for life support applications or applications where malfunctioning could result in personal injury or property loss. Anyone using this product for such applications does so at his/her own risk. Tek-Trol Technology Solutions shall not be held liable for damages resulting from such improper use.</i>• <i>Failure to follow installation guidelines could result in death or serious injury. Make sure only qualified personnel perform the installation.</i>• <i>Never remove the instrument cover in explosive environments when the circuit is live.</i>• <i>Cover must be fully engaged to meet flameproof/explosion-proof requirements.</i>• <i>Information in this manual supersedes all enclosure, compliance, and agency approval information included in additional product manuals included with this product.</i>
--	---

Limited Warranty

Tek-Trol Technology Solutions warrants this product against defects in material or workmanship for the specified period under “Specifications” from the date of shipment from the factory. Tek-trol's liability under this limited warranty shall not exceed the purchase value, repair, or replacement of the defective unit.

Registered Trademarks

MeterView® Pro is a registered trademark of Tek-Trol Technology Solutions. Modbus® is a Registered Trademark of Schneider Automation Inc. All other trademarks mentioned in this document are the property of their respective owners.

© 2018 Tek-Trol Technology Solutions. All rights reserved.

www.Tek-Trol.com

Introduction

The Tek-Batch 7900A is an analog input (4-20 mA, 0-5 V, 1-5 V, etc.) digital batch controller specifically designed for single and multi-stage batching applications. It provides excellent but simple batch control capabilities with features such as preclose relays and automatic overrun correction for more accurate batches and convenient SafeTouch® through-glass buttons for simple operation and menu navigation without having to remove the cover. The preclose deactivates a specific relay before the batch is finished in order to allow slower fill rates and increased accuracy. Automatic overrun correction keeps the batch size accurate over time and with system wear.

Specifications

Except where noted all specifications apply to operation at +25°C.

General

Display	Line 1: 0.6" (15 mm) high, red LEDs Line 2: 0.46" (12 mm) high, red LEDs 6 digits: each (-99999 to 999999), with lead zero blanking.
Default Display Assignment	The Upper display shows batch total. The Lower display shows rate with alternating units, and can be switched to show grand total, batch count, or preset with the STOP key.
Custom Display Assignment	Display lines 1 & 2 may be assigned to rate, total, grand total, batch count, preset, set points, units (line 2 only), alternating R & T, R & GT, preset & rate, max & min, or a Modbus display register. Any rate/total/grand total display may be programmed to alternate with a custom unit or tag.
Alternating Display	Displays alternate every 10 seconds when display is selected or the batch is paused.
Display Intensity	Eight user selectable intensity levels
Display Update Rate	5/second (200 ms)
Overrange	Display flashes 999999
Underrange	Display flashes -99999
Front Panel	NEMA 4X, IP65
Programming Methods	Four front panel buttons, digital inputs, or PC and MeterView Pro software.
Noise Filter	Programmable from 2 to 199 (0 will disable filter)
Filter Bypass	Programmable from 0.1 to 99.9% of calibrated span
Recalibration	All ranges are calibrated at the factory. Recalibration is recommended at least every 12 months.
Max/Min Display	Max/min readings reached by the process are stored until reset by the user or until power to the controller is cycled.
Password	Three programmable passwords restrict modification of programmed settings and two prevent resetting the totals. Pass 1: Allows use of function keys and digital inputs Pass 2: Allows use of function keys, digital inputs and editing set/reset points Pass 3: Restricts all programming, function keys, and digital inputs. Total Password: Prevents resetting the total manually Gtotal Password: Prevents resetting the grand total manually
Non-Volatile Memory	All programmed settings are stored in non-volatile memory for a minimum of ten years if power is lost.
Power Options	85-265 VAC 50/60 Hz, 90-265 VDC, 20 W max or 12-24 VDC \pm 10%, 15 W max Powered over USB for configuration only

Fuse	Required external fuse: UL Recognized, 5 A max, slow blow; up to 6 controllers may share one 5 A fuse
Isolated Transmitter Power Supply	Terminals P+ & P-: 24 VDC \pm 10%. selectable for 24, 10, or 5VDC supply (internal jumper J4). All models transmitter supply rated @ 25mA max.
Normal Mode Rejection	Greater than 60 dB at 50/60 Hz
Isolation	4 kV input/output-to-power line 500 V input-to-output or output-to-P+ supply
Overvoltage Category	Installation Overvoltage Category II: Local level with smaller transient overvoltages than Installation Overvoltage Category III.
Environmental	T6 Class operating temperature range Ta = -40 to 60°C T5 Class operating temperature range Ta = -40 to 65°C
Max Power Dissipation	Maximum power dissipation limited to 15.1 W.
Connections	Screw terminals accept 12 to 22 AWG wire
Enclosure	NEMA 4X, 7, & 9, IP68. Default conduit connections: Four ¾" NPT threaded conduit openings and two ¾" NPT metal conduit plugs with 12 mm hex key fitting installed. Additional conduit opening configurations may be available; verify quantity and sizes on specific device labeling during installation.
Mounting	Four slotted flanges for wall mounting or NPS 1½" to 2½" or DN 40 to 65 mm pipe mounting. See Mounting Dimensions on page 61.
Tightening Torque	Screw terminal connectors: 5 lb-in (0.56 Nm)
Overall Dimensions	6.42" x 7.97" x 8.47" (W x H x D) (163 mm x 202 mm x 215 mm)
Weight	16.0 lbs (7.26 kg)
Warranty	3 years parts & labor
Process Input	
Inputs	Field selectable: 0-20, 4-20 mA, \pm 10 V (0-5, 1-5, 0-10 V), Modbus PV (Slave)
Accuracy	\pm 0.03% of calibrated span \pm 1 count, square root & programmable exponent accuracy range: 10-100% of calibrated span
Temperature Drift	0.005% of calibrated span/°C max from 0 to 65°C ambient, 0.01% of calibrated span/°C max from -40 to 0°C ambient

Signal Input Conditioning	Linear, square root, or programmable exponent								
Multi-Point Linearization	2 to 32 points								
Programmable Exponent	1.0001 to 2.9999								
Low-Flow Cutoff	0-999999 (0 disables cutoff function)								
Decimal Point	Up to five decimal places or none: d.ddddd, d.dddd, d.ddd, d.dd, d.d, or ddddd								
Calibration Range	<table border="0"> <tr> <td>Input Range</td> <td>Minimum Span</td> </tr> <tr> <td>4-20 mA</td> <td>Input 1 & Input 2</td> </tr> <tr> <td>±10 V</td> <td>0.15 mA</td> </tr> <tr> <td></td> <td>0.01 V</td> </tr> </table> <p>An error message will appear if the input 1 and input 2 signals are too close together.</p>	Input Range	Minimum Span	4-20 mA	Input 1 & Input 2	±10 V	0.15 mA		0.01 V
Input Range	Minimum Span								
4-20 mA	Input 1 & Input 2								
±10 V	0.15 mA								
	0.01 V								
Input Impedance	Voltage ranges: greater than 500 kΩ Current ranges: 50 - 100 Ω (depending on resettable fuse impedance)								
Input Overload	Current input protected by resettable fuse, 30 VDC max. Fuse resets automatically after fault is removed.								
F4 Digital Input Contacts	3.3 VDC on contact. Connect normally open contacts across F4 to COM.								
F4 Digital Input Logic Levels	Logic High: 3 to 5 VDC Logic Low: 0 to 1.25 VDC								
HART Transparency	Analog input will not interfere with existing HART communications on the wired 4-20 mA signal								

Batch Controller Rate/Totalizer Display

Rate Display Indication	-99999 to 999999, lead zero blanking. "R" LED illuminates while displaying rate.
Batch Total & Grand Total Display	0 to 999,999; automatic lead zero blanking. "T" LED is illuminated while displaying batch total. "GT" LEDs are illuminated while displaying grand total. Up to 999,999 for batch total/preset. Up to 999,999,999 with grand total-overflow feature. "OF" is displayed to the left of grand total overflow and ▲ LED is illuminated.
Batch Total Decimal Point	Up to five decimal places or none: d.ddddd, d.dddd, d.ddd, d.dd, d.d, or ddddd Total decimal point is independent of rate decimal point.
Totalizer	Calculates total based on rate and field programmable multiplier to display total in engineering units. Time base must be selected according to the time units in which the rate is displayed.
Grand Totalizer Rollover	Grand totalizer rolls over when display exceeds 999,999,999. Relay status reflects display.

Grand Total Alarms	Up to seven, user selectable under setup menu. Any set point can be assigned to grand total and may be programmed anywhere in the range of the controller for grand total alarm indication. Relay 1 should always be assigned to batch.
Programmable Delay on Release	0.1 and 999.9 seconds; applied to the first relay assigned to total or grand total. If the controller is programmed to reset total to zero automatically when the preset is reached, then a delay will occur before the total is reset.
Grand Total Reset	Via front panel button, external contact closure on digital inputs, automatically via user selectable preset value and time delay, or through serial communications.
Grand Total Reset Password	Grand total passwords may be entered to prevent resetting the grand total from the front panel.
Non-Resettable Grand Total	The grand total can be programmed as a non-resettable total by entering the password "050873". <i>Once the Grand Total has been programmed as "non-resettable" the feature cannot be disabled.</i> Caution!

Relays

Rating	2 or 4 SPDT (Form C) internal and/or 4 SPST (Form A) external; rated 3 A @ 30 VDC and 125/250 VAC resistive load; 1/14 HP (≈ 50 W) @ 125/250 VAC for inductive loads
Relay Assignment	Relays may be assigned to batch control total, sampling, rate, or grand total alarms.
Alarm Deadband	0-100% of span, user programmable
Relay Operation	Batch control Automatic (non-latching) ¹ Sampling Off (disable unused relays and enable Interlock feature) Manual on/off control mode Secondary Functions ² Pump alternation control (2 to 4 relays) Latching (requires manual acknowledge)
Relay Reset	User selectable via front panel buttons, digital inputs, or PC <ul style="list-style-type: none"> 1. Automatic reset only (non-latching), when the input passes the reset point or total is reset to zero. 2. Automatic + manual reset at any time (non-latching) 3. Manual reset only, at any time (latching) 4. Manual reset only after alarm condition has cleared (L) <i>Note: Digital inputs may be assigned to acknowledge relays programmed for manual reset. It is not recommended to change the functions of front panel buttons to manual reset.</i>

High or Low Alarm	User may program any alarm for high or low trip point. Unused alarm LEDs and relays may be disabled (turn off).
Preclose	0-100% of batch size, individually user programmable for each additional batch control relay beyond the first.
Alarm Time Delay	0 to 999.9 seconds, on & off relay time delays Programmable and independent for each relay.
Noise Suppression	Noise suppression is recommended for each relay contact switching inductive loads; see page 19 for details.
Fail-Safe Operation	Programmable and independent for each relay. <i>Note: Relay coil is energized in non-alarm condition. In case of power failure, relay will go to alarm state.</i>
Alarm Auto Initialization	When power is applied to the controller, relays will reflect the state of the input to the controller. ¹

1. Alarms are active only when the batch is running.
2. These functions are not functional when the unit is being used as a batch controller with total set to yes.

Isolated 4-20 mA Transmitter Output

Output Source	Rate/process, total, grand total, max, min, set points 1-4, Modbus register, or manual control mode		
Scaling Range	1.000 to 23.000 mA for any display range.		
Calibration	Factory calibrated: 4.000 to 20.000 = 4-20 mA output		
Analog Out Programming	23.000 mA maximum for all parameters: Overrange, underrange, max, min, and break		
Accuracy	± 0.1% FS ± 0.004 mA		
Temperature Drift	0.4 µA/°C max from 0 to 65°C ambient, 0.8 µA/°C max from -40 to 0°C ambient <i>Note: Analog output drift is separate from input drift.</i>		
Isolated Transmitter Power Supply	Terminals I+ & R: 24 VDC ± 10% . May be used to power the 4-20 mA output or other devices. Refer to Figure 16 on page 20. All models @ 25mA max.		
External Loop Power Supply	35 VDC maximum		
Output Loop Resistance	Power supply	Minimum	Maximum
	24 VDC	10 Ω	700 Ω
	35 VDC (external)	100 Ω	1200 Ω

Serial Communications

Compatibility	EIA-485
Connectors	Removable screw terminal connector
Max Distance	3,937' (1,200 m) max
Status Indication	Separate LEDs for Power (P), Transmit (TX), and Receive (RX)
Slave Id	1 – 247 (Controller address)
Baud Rate	300 - 19,200 bps
Transmit Time Delay	Programmable between 0 and 199 ms
Data	8 bit (1 start bit, 1 or 2 stop bits)
Parity	Even, Odd, or None with 1 or 2 stop bits
Byte-To-Byte Timeout	0.01 – 2.54 second
Turn Around Delay	Less than 2 ms (fixed)

Note: Refer to the PROVu® Modbus Register Tables located at www.predig.com for details.

Digital Inputs & Outputs

Channels	4 digital inputs & 4 digital outputs
Digital Input Logic High	3 to 5 VDC
Digital Input Logic Low	0 to 1.25 VDC
Digital Output Logic High	3.1 to 3.3 VDC
Digital Output Logic Low	0 to 0.4 VDC
Source Current	10 mA maximum output current
Sink Current	1.5 mA minimum input current
+5 V Terminal	To be used as pull-up for digital inputs only. Connect normally open pushbuttons across +5 V & DI 1-4.  DO NOT use +5 V terminal (pin 1) to power external devices. WARNING
Function Assignment	The on-board digital inputs (1-4) are designed to mimic the behavior of the front panel buttons (Menu, F1, F2, & F3). If you wish to change their behavior, reassign F1-F3 to the desired function, then change the corresponding digital input to match.

MeterView Pro

System Requirements	Microsoft® Windows® XP/Vista/7/8/10
Communications	USB 2.0 (Standard USB A to Micro USB B)
Configuration	Configure device settings one at a time

Compliance Information

Safety

UL & c-UL Listed	USA & Canada UL 508 Industrial Control Equipment
UL File Number	E160849
Front Panel	UL Type 4X, NEMA 4X, IP65; panel gasket provided
Low Voltage Directive	EN 61010-1:2010 Safety requirements for measurement, control, and laboratory use

Electromagnetic Compatibility

Emissions	EN 55022:2010 Class A ITE emissions requirements
Radiated Emissions	Class A
AC Mains Conducted Emissions	Class A
Immunity	EN 61326-1:2013 Measurement, control, and laboratory equipment EN 61000-6-2:2005 EMC heavy industrial generic immunity standard
RFI - Amplitude Modulated	80 -1000 MHz 10 V/m 80% AM (1 kHz) 1.4 - 2.0 GHz 3 V/m 80% AM (1 kHz) 2.0 - 2.7 GHz 1 V/m 80% AM (1 kHz)
Electrical Fast Transients	±2kV AC mains, ±1kV other
Electrostatic Discharge	±4kV contact, ±8kV air
RFI - Conducted	10V, 0.15-80 MHz, 1kHz 80% AM
AC Surge	±2kV Common, ±1kV Differential
Surge	1KV (CM)
Power-Frequency Magnetic Field	30 A/m 70%V for 0.5 period
Voltage Dips	40%V for 5 & 50 periods 70%V for 25 periods
Voltage Interruptions	<5%V for 250 periods

Safety Information



WARNINGS

- Read complete instructions prior to installation and operation of the instrument.
- Installation and service should be performed only by trained service personnel. Service requiring replacement of internal sub-components must be performed at the factory.
- Disconnect from supply before opening enclosure. Keep cover tight while circuits are alive. Conduit seals must be installed within 18" (450mm) of the enclosure or within 2" (50mm) for Zone installations.
- Verify that the operating atmosphere of the instrument is consistent with the appropriate hazardous locations certifications.
- If the instrument is installed in a high voltage environment and a fault or installation error occurs, high voltage may be present on any lead
- Read all product labels completely and follow all instructions and requirements listed on the labels for installation or service.

Installation

Install in accordance with applicable local and national regulations (e.g. NEC).

For Installation in USA: The Tek-Batch 7900A must be installed in accordance with the National Electrical Code (NEC) NFPA 70.

For Installation in Canada: The Tek-Batch 7900A must be installed in accordance with the Canadian Electrical Code CSA 22.1. All power supplies below 36 V and input circuits must be derived from a CSA Approved Class 2 source.

For European Community: The Tek-Batch 7900A must be installed in accordance with the ATEX directive 94/9/EC and the product certificate Sira 12ATEX1182.



WARNING

Disconnect from supply before opening enclosure. Keep cover tight while circuits are alive. Conduit seals must be installed within 18" (450mm) of the enclosure or within 2" (50mm) for Zone installations.

Wiring connectors are accessed by opening the enclosure. To access electrical connectors, remove the 2 captive screws and then remove the electronics module. Connectors are on the rear of the electronics module.

Unpacking

Remove the instrument from packing box. Inspect the packaging and contents for damage. Report damages, if any, to the carrier.

If any part is missing or the instrument malfunctions, please contact your supplier or the factory for assistance.

Pre-Installed Conduit/Stopping Plug

The Tek-Batch 7900A is supplied with two pre-installed conduit plugs for installations that do not require the use of all conduit entries. The conduit/stopping plugs include an internal 12mm hexagonal socket recess for removal. The pre-installed plugs and their installation are included in the hazardous area approvals for the Tek-Batch Series enclosure.

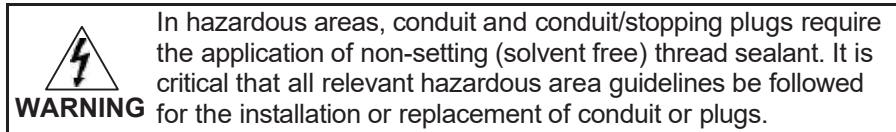

Mounting

The Tek-Batch 7900A has four slotted mounting flanges that should be used for pipe mounting or wall mounting. Refer to *Mounting Dimensions*, page 61 for details.

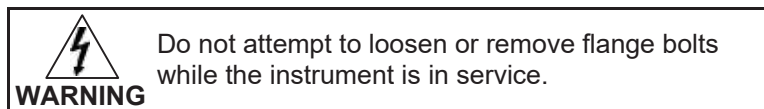

Cover Jam Screw

The cover jam screw should be properly installed once the instrument has been wired and tested in a safe environment. The cover jam screw is intended to prevent the removal of the instrument cover in a flameproof environment without the use of tools. Using a M2 hex wrench, turn the screw clockwise until the screw contacts the aluminum enclosure. Turn the screw an additional 1/4 to 1/2 turn to secure the cover. Caution: Excess torque may damage the threads and/or wrench.

Transmitter Supply Voltage Selection (P+, P-)

All controllers, including models equipped with the 12-24 VDC power option, are shipped from the factory configured to provide 24 VDC power for the transmitter or sensor.

If the transmitter requires 5 or 10 VDC excitation, the internal jumper J4 must be configured accordingly.

To access the voltage selection jumper:

1. Remove all the connectors.
2. Unscrew the back cover.
3. Slide the back cover about 1 inch.
4. Configure the J4 jumper, located behind the input signal connector, for the desired excitation voltage as shown.

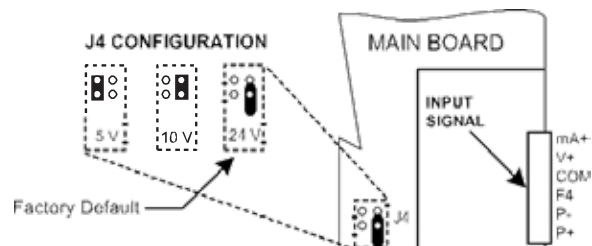

Figure 1: Transmitter Supply Voltage Selection

Connections



- Static electricity can damage sensitive components.
- Observe safe handling precautions for static-sensitive components.
- Use proper grounding procedures/codes.
- If the instrument is installed in a high voltage environment and a fault or installation error occurs, high voltage may be present on any lead or terminal.
- Follow all fusing and wiring precautions requirements for the instrument integrated to the PD8 Series model number being connected.

To access the connectors, remove the enclosure cover and unscrew the two captive screws that fasten the electronics module. Signal connections are made to de-pluggable connectors on the back of the electronics module.

Some connectors may be provided already connected. These connections are required for proper operation of the Tek-Batch 7900A , and should not be removed unless instructed to by this manual.

Wires marked as being used for testing purposes should be removed.

Grounding connections are made to the two ground screws provided on the base – one internal and one external.

After all connections have been completed and verified, apply power to the unit.

Required & Factory Wired Connection

The Tek-Batch 7900A comes with a pre-wired connection. This connection is detailed below, and must be maintained in order for the instrument to function properly.



Observe all safety regulations. Electrical wiring should be performed in accordance with all agency requirements and applicable national, state, and local codes to prevent damage to the meter and ensure personnel safety.

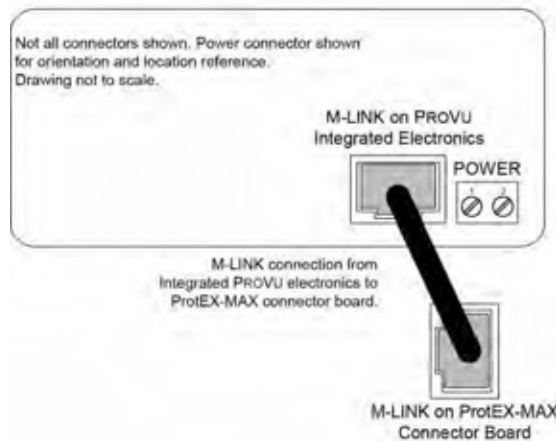

Figure 2: Integrated ProVu Required Connections

Connectors Labeling

The connectors' label, affixed to the controller, shows the location of all connectors available with requested configuration.

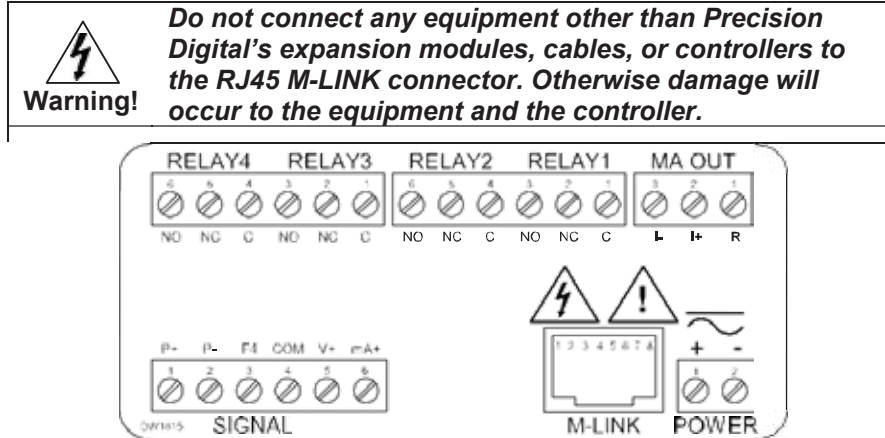

Figure 3: Connector Labeling for Fully Loaded Tek-Batch 7900A

Power Connections

Power connections are made to a two-terminal connector labeled POWER on Figure 6. The controller will operate regardless of DC polarity connection. The + and - symbols are only a suggested wiring convention.

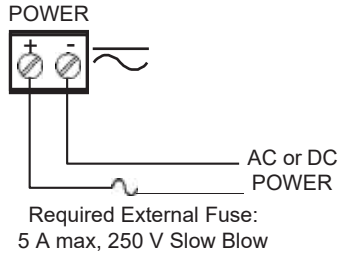

Figure 4: Power Connections

Signal Connections

Signal connections are made to a six-terminal connector labeled SIGNAL on Figure 6. The COM (common) terminal is the return for the 4-20 mA and the ± 10 V input signals.

Current and Voltage Connections

The following figures show examples of current and voltage connections.

There are no switches or jumpers to set up for current and voltage inputs. Setup and programming is performed through the front panel buttons.

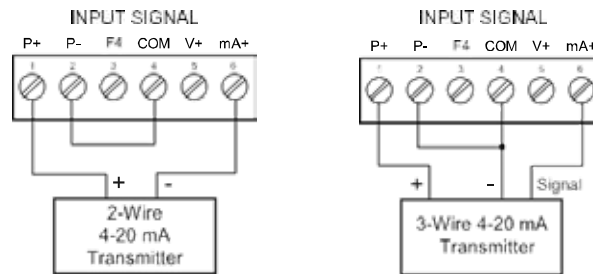

Figure 5: Transmitters Powered by Internal Supply

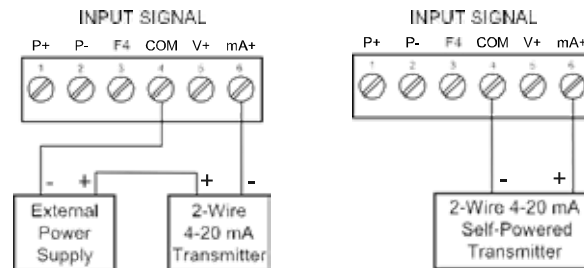

Figure 6: Transmitter Powered by Ext. Supply or Self-Powered

The current input is protected against current overload by a resettable fuse. The display may or may not show a fault condition depending on the nature of the overload.

The fuse limits the current to a safe level when it detects a fault condition, and automatically resets itself when the fault condition is removed.

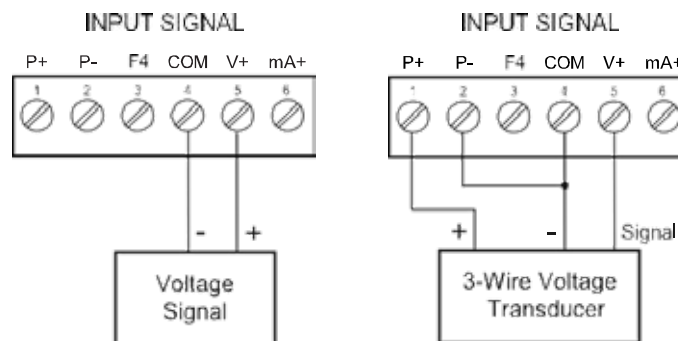

Figure 7: Voltage Input Connections

The controller is capable of accepting any voltage from -10 VDC to +10 VDC.

Serial Communications Connections

The Tek-Batch 7900A has a 5 position terminal block for connecting RS-485 serial devices. Figure 8 details the wiring connections from the Tek-Batch 7900A to an RS-485 serial converter

Tek-Batch 7900A to RS-485 Serial Converter Connections	
RS-485 Serial Converter	7900A RS-485 Connections
\perp	\perp
\overline{DO}	\overline{DI}
DO	DI
\overline{DI}	\overline{DO}
DI	DO

Figure 8: Tek-Batch 7900A Connections to a Serial Converter

The Tek-Batch 7900A has three diagnostic LEDs: a Power (P) LED to show when the module is powered properly, a Transmit Data (TX) LED to show when the module is being transmitted to by the PC side, and a Receive Data (RX) LED to show when the module is sending data to a receiving device. The following diagrams detail how to connect the RS-485 serial communications from the Tek-Batch 7900A to a RS-485/RS-232 serial converter in four wire and two wire configurations.

Three Wire Connections

In order to wire the 5 pins for use as a 3-wire half-duplex RS-485 connection, it is necessary to create a jumper connection between DI – DO and \overline{DI} – \overline{DO} as shown below.

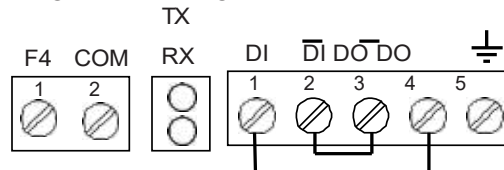

Figure 9. Three-Wire RS485 Connection

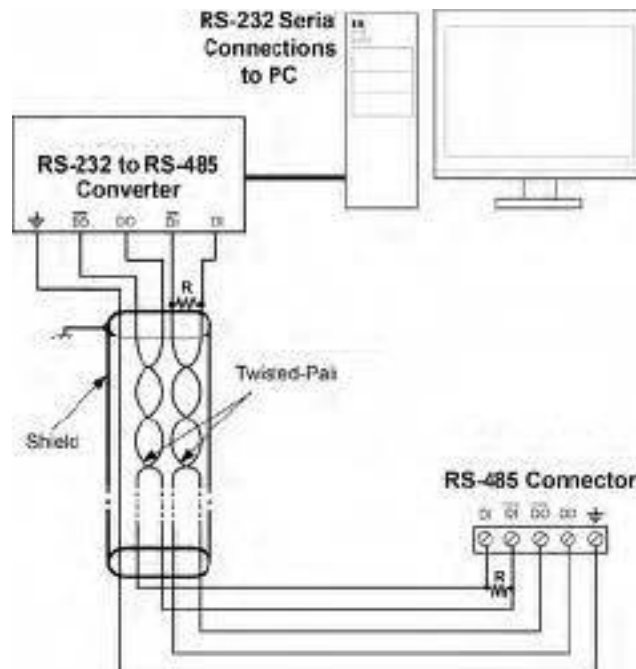

Figure 10: RS-485 Wiring

Notes:

1. Termination resistors are optional and values depend on the cable length and characteristic impedance. Consult the cable manufacturer for recommendations.
2. Refer to RS-232 to RS-485 Converter documentation for further details.
3. Use shielded cable, twisted-pairs plus ground. Connect ground shield only at one location.



Observe all safety regulations. Electrical wiring should be performed in accordance with all agency requirements and applicable national, state, and local codes to prevent damage to the meter and ensure personnel safety.

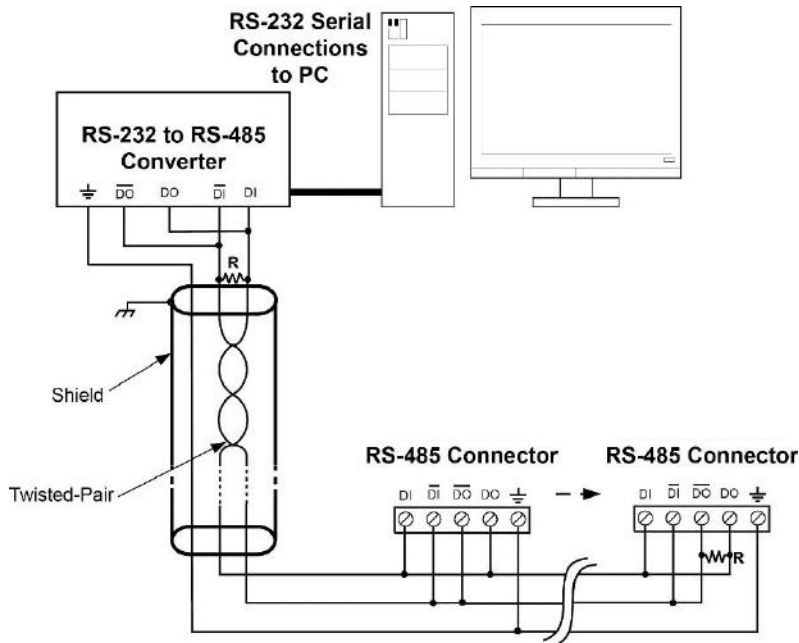



Figure 11: RS-485 Two-Wire Multi-Drop Wiring

Notes:

1. Termination resistors are optional and values depend on the cable length and characteristic impedance. Consult the cable manufacturer for recommendations.
2. Refer to RS-232 to RS-485 Converter documentation for further details.
3. Use shielded cable, twisted-pair plus ground. Connect ground shield only at one location.

 WARNING	Observe all safety regulations. Electrical wiring should be performed in accordance with all agency requirements and applicable national, state, and local codes to prevent damage to the meter and ensure personnel safety.
---	--

When using more than one instrument in a multi-drop or multi-point mode, each meter must be provided with its own unique address.

Relay Connections

Relay connections are made to two six-terminal connectors labeled RELAY1 – RELAY4 on Figure 7. Each relay's C terminal is common only to the normally open (NO) and normally closed (NC) contacts of the corresponding relay. The relays' C terminals should not be confused with the COM (common) terminal of the INPUT SIGNAL connector.

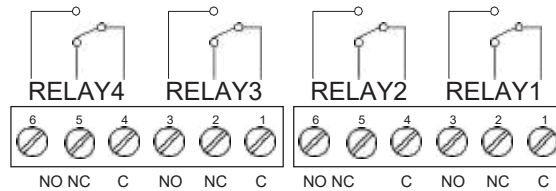

Figure 12: Relay Connections

Switching Inductive Loads

The use of suppressors (snubbers) is strongly recommended when switching inductive loads to prevent disrupting the microprocessor's operation. The suppressors also prolong the life of the relay contacts. Suppression can be obtained with resistor-capacitor (RC) networks assembled by the user or purchased as complete assemblies. Refer to the following circuits for RC network assembly and installation:

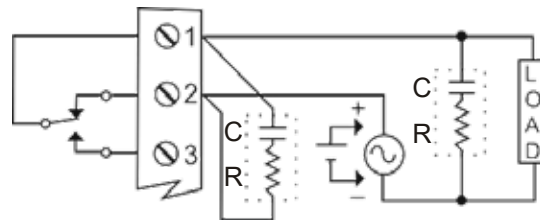

Figure 13: AC and DC Loads Protection

Choose R and C as follows:

- R: 0.5 to 1 Ω for each volt across the contacts
- C: 0.5 to 1 μF for each amp through closed contacts

Notes:

1. Use capacitors rated for 250 VAC.
2. RC networks may affect load release time of solenoid loads. Check to confirm proper operation.
3. Install the RC network at the controller's relay screw terminals. An RC network may also be installed across the load. Experiment for best results.

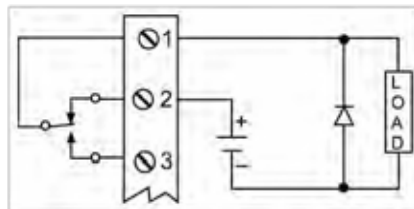

Use a diode with a reverse breakdown voltage two to three times the circuit voltage and forward current at least as large as the load current.

Figure 14: Low Voltage DC Loads Protection

F4 Digital Input Connections

A digital input, F4, is standard on the meter. This digital input connected with a normally open closure across F4 and COM, or with an active low signal applied to F4.

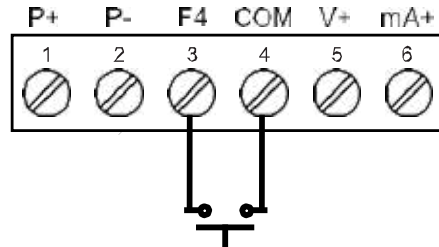

Figure 15: F4 Digital Input Connections

4-20 mA Output Connections

Connections for the 4-20 mA transmitter output are made to the connector terminals labeled MA OUT. The 4-20 mA output may be powered internally or from an external power supply.

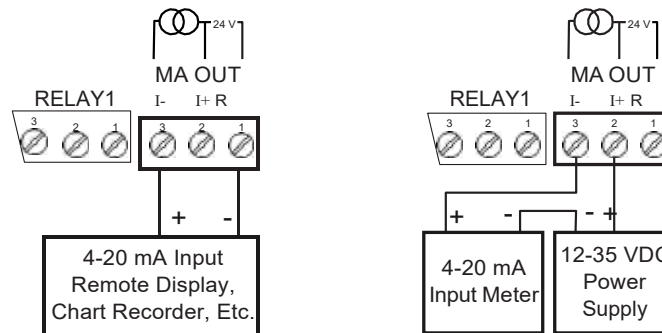

Figure 16: 4-20 mA Output Connections

Analog Output Transmitter Power Supply

The internal 24 VDC power supply powering the analog output may be used to power other devices, if the analog output is not used. The I+ terminal is the +24 V and the R terminal is the return.

Interlock Relay Feature

As the name implies, the interlock relay feature reassigns one, or more, alarm/control relays for use as interlock relay(s). Interlock contact(s) are wired to digital input(s) and trigger the interlock relay. This feature is enabled by configuring the relay, and relative digital input(s) (see page 41). In one example, dry interlock contacts are connected in series to one digital input which will be used to force on (energize) the assigned interlock power relay when all interlock contacts are closed (safe). The interlock relay front panel LED flashes when locked out. The interlock relay would be wired in-series with the load (N/O contact). See below.

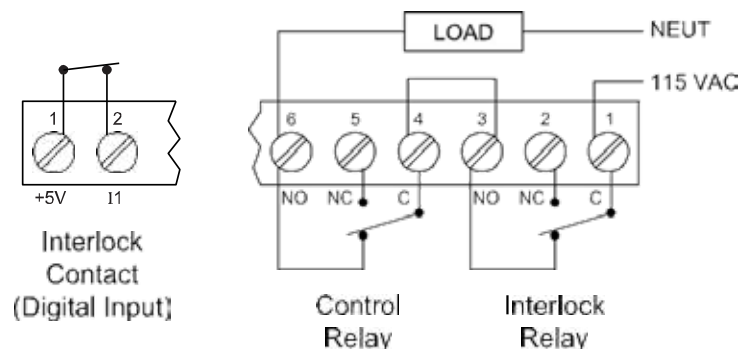

Figure 17: Interlock Connection

Digital I/O Connections

The Tek-Batch 7900A has a 10 position terminal block for connecting digital inputs and outputs.

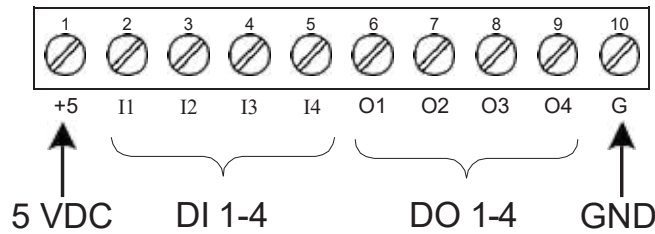



Figure 18: Digital I/O Connections

NOTICE	<p>The onboard digital inputs (1-4) are configured at the factory to function identically to the front panel pushbuttons (Menu, F1, F2, & F3) in order to work with the SafeTouch buttons. Changing the programming of the digital inputs will affect the function of the SafeTouch buttons. If you wish to change the behavior of the digital inputs, re-assign F1-F3 to the desired function, then change the corresponding digital input to match.</p>
 WARNING	<p>Observe all safety regulations. Electrical wiring should be performed in accordance with all agency requirements and applicable national, state, and local codes to prevent damage to the meter and ensure personnel safety.</p>

External Switch Contacts

The Tek-Batch 7900A includes 4 digital inputs. These digital inputs are preconfigured at the factory to function as external contacts to duplicate the front button functions of the instrument. The factory configuration uses the following corresponding digital input terminals for external switch contacts.

Digital In-put Con-nection	Factory Default Func-tion
I1	MENU
I2	RIGHT arrow
I3	UP arrow
I4	ENTER arrow

See Digital Inputs & Outputs in the Specification on page 8 for details on the digital inputs.

NOTICE	<p>The digital inputs are configured at the factory to function identically to the front panel pushbuttons in order to work with the SafeTouch buttons. Changing the programming of the digital inputs will affect the function of the SafeTouch buttons.</p>
---------------	---

Basic Operation and Programming

The Tek-Batch 7900A is factory calibrated prior to shipment to read in milliamps and volts depending on the input selection. The calibration equipment is traceable to NIST standards.

Overview

There are no jumpers to set for the meter input selection.

Setup and programming may be done through the infrared through-glass SafeTouch buttons, or using the mechanical buttons when uncovered. There is a slide switch located on the connector board. This is used to enable or disable SafeTouch Buttons.

After power and input signal connections have been completed and verified, apply power to the meter.

SafeTouch® Buttons

The Tek-Batch 7900A is equipped with four sensors that operate as through-glass buttons so that it can be programmed and operated without removing the cover (and exposing the electronics) in a hazardous area.

These buttons can be disabled for security by selecting DISABLE on the switch labeled NO-CONTACT BUTTONS located on the connector board.

To actuate a button, press one finger to the glass directly over the marked button area. Then retract finger more than three inches from the glass before pressing the next button. When the cover is removed, the four mechanical buttons located next to the sensors are used. The sensors are disabled when a mechanical button is pressed and will automatically be re-enabled after 60 seconds of inactivity.

The SafeTouch Buttons are designed to filter normal levels of ambient interference and to protect against false triggering, however, it is recommended that the SafeTouch Buttons be disabled (slide switch to LOCK) if there is an infrared interference source in line-of-sight to the display.

The SafeTouch Buttons are configured by default to duplicate the function of the front panel mechanical pushbuttons associated with the integrated meter. The symbols by each SafeTouch button correspond to a mechanical button as shown in the table on the next page.

SafeTouch Button Tips:

- To the extent possible, install the display facing away from sunlight, windows, reflective objects and any sources of infrared interference.
- Keep the glass window clean.
- Tighten the cover securely.
- Use a password to prevent tampering.



Take caution when cleaning the window glass as it may result in un-intentional SafeTouch button events. Only clean the Tek-Batch 7900A when the system is safely shut down, and inspect the Tek-Batch 7900A for proper configuration prior to system restart.

Front Buttons and Status LED Indicators



Button Symbol	Description	LED	Status
	Menu	1-8	Relay 1 – 8 indicators
	START (Right arrow/F1)	R	Rate indicator
	BATCH (Up arrow/F2)	T	Batch Total indicator
	STOP (Enter/F3)	G T	Grand Total indicator
<p><i>Note:</i> F4 is a digital input.</p>		▲	Total overflow indicator
		M	Manual control relays &/or analog output

Programming

- Press the Menu button to enter or exit the Programming Mode at any time.
- Press the Right arrow button to move to the next digit during digit or decimal point programming.
- Press or hold the Up arrow button to scroll through the menus, decimal point or press or hold to increment the value of a digit.
- Press the Enter button to access a menu or to accept a setting.
- Press and hold the Menu button for three seconds to access the advanced features of the controller.

Controller Operation

The Tek-Batch 7900A controller is capable of accepting current (0-20 mA, 4-20 mA) and voltage signals (0-5 V, 1-5 V, 0-10 V, ± 10 V).

These signals are scaled to represent rate in engineering units from -99999 to 999999.

The default configuration displays batch total on the upper display, and a selection of rate, grand total, batch count, and preset on the lower display.

When in pause or stop mode, the display will alternate the numeric value with the run status in the upper display and the display label for the lower display.

The controller has up to 4 relays on board which are used to either control the batch process in single or multi-stage batch control, or as alarms that will be active when the batch process is running. A 4-20 mA output option is also available for retransmitting the process variable analog or pulse signal.

Default Batch Control Operation

The following describes the operation of the three front panel operating keys as programmed with default settings.

START Button

Press the START button to begin a new batch process.

BATCH Button

Press the Batch button to access the Preset (batch amount) menu. Program the batch with the arrow keys, and confirm with the Enter key.

STOP Button

Press the STOP key once during a batch to pause. Press the STOP key while paused to stop and cancel the batch. Press the STOP key while in stop/ready mode cycle lower display values of rate (or other lower display programmed parameter), grand total, batch count, and preset.

Only STOP Button Enabled if a Batch is Running

During a batch process, only the pause/stop functions of the STOP button will function. No other buttons will be functional.

Batch Control Operation Example

The following example shows how two stage batch control functions with a Tek-Batch 7900A. This setup will establish a 55 gallon preset for the batch, with a main valve (high flow) that will close at 50 gallons, and a trickle valve (low or restricted flow) that will close at 55 gallons. After the batch, the preset will be changed to 100 gallons.

Two-Stage Batch Control Setup Using Relays 1 & 2

The following table shows the parameters as they appear within the Setup menu entry relay.

Parameter	Setting	Function
Relay	Assign	Press Enter to enter the relay assignment parameters.
Asign1	total	Assign relay 1 to batch total control.
Asign2	total	Assign relay 2 to batch total control.
Precis Total		Press Enter to access preclose selection for multi-stage control.
Precis	Yes	Yes to enable a preclose value for relay 2.
Yes	00005.0	Set the preclose value to 5 for closing the valve controlling relay 2 five gallons before reaching the preset.
...		Assignment for optional relays 3-8.
Rly 1 relay		Select relay 1 setup.
Act 1 rly 1		Configure activation of relay 1.
Act 1	Auto	Always set to Auto for batch control function.
Rly 1	Preset	Set the preset value for batch control.
Preset	00055.0	Set 55 gallons as the preset.
...		Setup for optional relays 3-8.

The operation of relay 2 has already been assigned for multi-stage control preclose, and will not appear as a selection in the relay menu.

If only one stage batch control was desired, with one relay for control, then one would set the assignment of relay 2, assign2, to off, rate, or grand total.

The following pages show an illustration of how the above settings control the batch operation. The display assignment is the default.

Batch Control Operation

1. A new container is prepared for the batch. Both valves are closed. Note that display line 1 may show the batch total from the last batch.
2. The START button is pressed. Both valves open. The barrel begins to fill as the total being dispensed is displayed on line 1. Line 2 shows the rate and units, alternating.
3. When the batch total reaches 50 gallons, the preset (55) minus the preclose amount (5) for relay 2, relay 2 deactivates to close the main valve. The barrel fills more slowly as a result, improving accuracy.
4. When the batch total equals the preset, relay 1 deactivates, closing valve 1. Filling stops.
5. The BATCH button is pressed, and a new preset is entered, 100 gallons, and the enter/STOP button is pressed to confirm it.
6. The new batch begins when the START button is pressed, so both relays activate and both valves open.

Additional Features

At any time during the batch, the STOP button may be pressed to pause the batch. When paused, the START button will continue the batch, and pressing the STOP button again will cancel the batch.

When in STOP mode, the STOP button may be pressed to cycle through alternative parameters to be displayed on the lower display, including the grand total, batch count, and preset.

The grand total and batch count may be reset in the reset menu by pressing the MENU button and entering the reset menu. It may also be reset with digital inputs.

MANUAL MULTI-STAGE BATCH CONTROL OPERATION

System Setup

- Both valves are closed with an empty barrel in place. The batched total is displayed in the upper display, the preset is selected for the lower display.

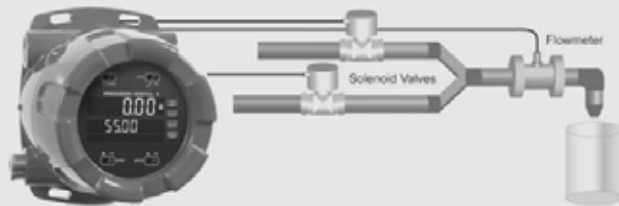

Batch Start

- The START button is pressed, with both valves open. The barrel begins to fill.

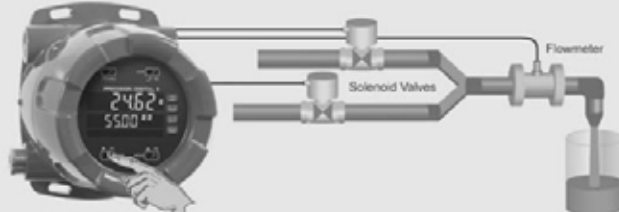

Preclose Valve

- When the batch total reaches a value of 50.00 (Preset[55.00] – Preclose[5.00]) the full-flow valve closes. The fill rate of the tank slows as a result.

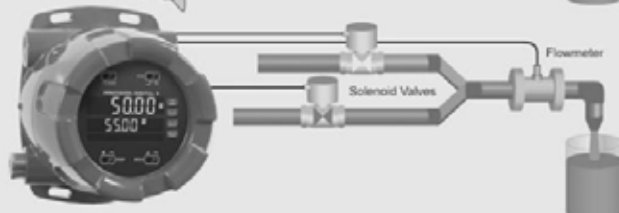

Completed Batch

- When the batch total equals the preset amount, the restricted-flow valve closes. The barrel is now full. If some overrun occurs, the next batch will adjust for this offset amount to maintain accuracy.

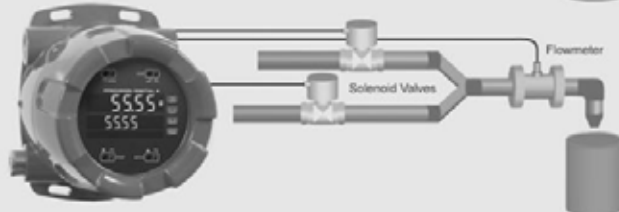

Change Preset

- After placing a new, empty barrel, a new preset fill amount may be selected with the BATCH key, while the process is stopped.

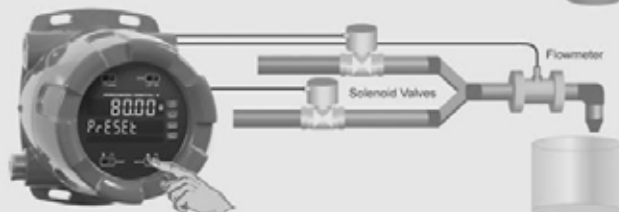

Begin New Batch

- Press the START key and a new batch will begin. With both valves open, the process continues.

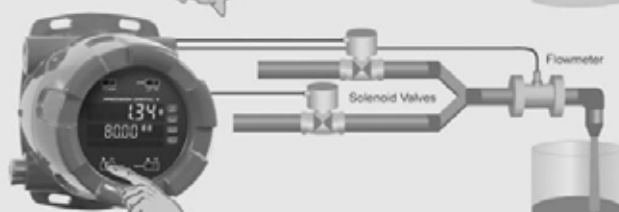

Pause/Stop

- At any time, the STOP button may be pressed, once to Pause the process, or twice to cancel the batch, which stops the process.

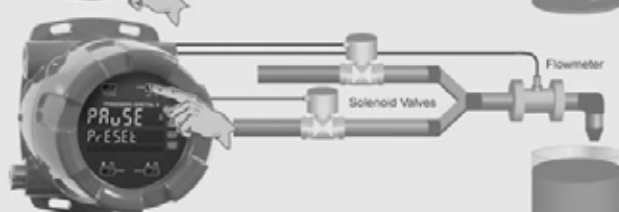

VALVE KEY LEGEND



MeterView® Pro Software

The meter can also be programmed using the PC-based MeterView Pro software included with the meter. This software can be installed on any Microsoft® Windows® (XP/Vista/7/8/10) computer by connecting the meter's onboard USB. The meter is powered by the USB connection, so there is no need to wire anything prior to programming the meter, though USB is intended only for meter configuration.

MeterView Pro Installation

1. Connect one end of the provided USB cable to the internal electronics module and the other end to the computer. The computer will automatically install the driver software it needs to talk to the meter. **Only one meter may be connected at a time. Attaching multiple meters will cause a conflict with the meter software.**

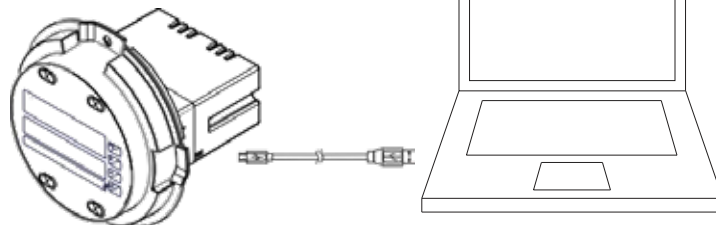

2. Once the driver is installed, an AutoPlay dialog should appear for the drive "MAINSTAL." Click "Open folder to view files." If the computer does not display an AutoPlay dialog for the drive "MAINSTAL," you should open My Computer and double-click on the drive labeled "MAINSTAL."
3. Double-click on the file named "MAStart." The program will open a few windows and install two programs on your computer. Simply follow the onscreen instructions until you see one of the dialogs below. If you receive a "User Account Control" warning, click "Yes."
4. If there is an update available, click the "Update" button to install the new version. Otherwise, click "Configure" to begin programming your meter.



Note: If you decide to update your MeterView Pro software, once the installation has completed, you will be asked if you want to update the setup files located on the meter itself. This way, you will always have the most current version on the meter for future installs.



Warning

Do not unplug the meter while the new installation files are being written to it. The meter will display *uwrite* during the process and you will receive an onscreen notification once the process is complete.

Display Functions and Messages

The controller displays various functions and messages during setup, programming, and operation. The following table shows the main menu functions and messages in the order they appear in the menu.

Display	Parameter	Action/Setting Description	Display	Parameter	Action/Setting Description
setup	Setup	Enter Setup menu	GT CF	Grand total conversion factor	Program grand total conversion factor
Input	Input	Enter Input selection menu	GT rst	Grand total reset	Program grand total reset mode: auto or manual
volt	0-10 VDC	Set input for ±10 VDC input	display	Display	Enter the Display menu
mA	4-20 mA	Set input for 4-20 mA input	Line 1	Display line 1	Press Enter to assign the Upper display parameter (default: PV or rate)
Total	Total	Enable or disable totalizer features	Line 2	Display Line 2	Press Enter to assign the Lower display parameter (default: total)
units	Units	Select the display units/tags	d-Inty	Display intensity	Set display intensity level from 1 to 8
rate	Rate	Select the display units for rate	RELaY	Relay	Enter the Relay menu
total	Total	Select the display units for total	Assign	Assignment	Assign relays to rate, total (batch control), grand total, or Modbus controlled.
Gtotal	Grand Total	Select the display units for grand total	Assign1	Assign 1	Relay 1-2 assignment
Dec pt	Decimal point	Set decimal point for rate, total, grand total	Total	Total	Assign relay to batch control
prog	Program	Enter the Program menu	Gtotal	Grand total	Assign relay to grand total
InCAL	Input Calibration	Enter the Input Calibration menu	mbus	Modbus	Assign relay to Modbus input
sCaIE	Scale	Enter the Scale menu	rate	Rate	Assign relay to rate
CaI	Calibrate	Enter the Calibrate menu	precls	Batch total relay preclose	For relays beyond the first assigned to total, a preclose amount may be entered.
Inp 1	Input 1	Calibrate input 1 signal or program input 1 value	RLY 1	Relay 1	Relay 1 setup
Dis 1	Display 1	Program display 1 value	Act 1	Action 1	Set relay 1 action ¹
Inp 2	Input 2	Calibrate input 2 signal or program input 2 value (up to 32 points)	Auto	Automatic	Set relay for automatic reset
Dis 2	Display 2	Program display 2 value (up to 32 points)	A-man	Auto-manual ¹	Set relay for automatic & manual reset any time ¹ (relays assigned to rate)
Error	Error	Error, calibration not successful, check signal or programmed value	Latch	Latching ¹	Set relay for latching operation (relays assigned to rate) ¹
T tb	Total time base	Enter totalizer time base for seconds, minutes, hours or day.	Lt-CLr	Latching-cleared ¹	Set relay for latching operation with manual reset only after alarm condition has cleared (relays assigned to rate) ¹
T Cf	Total conversion factor	Enter the conversion factor decimal point and the conversion factor.			
mode	Batch mode	Automatic or manual batch control			
T dly	Time delay	Set time delay for automatic batch restart			
GT tb	Grand total time base	Program grand total time base			

Display	Parameter	Action/Setting Description
Al tern	<i>Alternate</i> ²	Set relay for pump alternation control (relays assigned to rate) ²
Samp l	<i>Sampling</i>	Set relay for sampling operation (rate or GT)
OFF	<i>Off</i>	Disable relay and front panel status LED (Select Off to enable Interlock feature)
Pre set	<i>Preset</i>	Set batch preset
Set 1	<i>Set 1</i>	Program set point 1
RSt 1	<i>Reset 1</i>	Program reset point 1
RLY 2	<i>Relay 2</i>	Relays 2-4 setup.
Fail LSF	<i>Fail-safe</i>	Enter <i>Fail-safe</i> menu
FLS 1	<i>Fail-safe 1</i>	Set relay 1 fail-safe operation
on	<i>On</i>	Enable fail-safe operation
off	<i>Fail-safe off</i>	Disable fail-safe operation
DeL A Y	<i>Delay</i>	Enter relay <i>Time Delay</i> menu
DLY 1	<i>Delay 1</i>	Enter relay 1 time delay setup
On 1	<i>On</i>	Set relay 1 On timedelay
OFF 1	<i>Off</i>	Set relay 1 Off time delay
break	<i>Loop break</i>	Set relay condition if loop break detected (For mA input only)
i Gnor E	<i>Ignore</i>	Ignore loop break condition (Processed as a low signal condition)
On	<i>On</i>	Relay goes to alarm condition when loop break is detected
OFF	<i>Off</i>	Relay goes to non-alarm condition when loop break is detected
Aout	<i>Analog output</i>	Enter the <i>Analog output</i> scaling menu
Dis 1	<i>Display 1</i>	Program display 1 value
Out 1	<i>Output 1</i>	Program output 1 value (e.g. 4.000 mA)

Display	Parameter	Action/Setting Description
Dis 2	<i>Display 2</i>	Program display 2 value
Out 2	<i>Output 2</i>	Program output 2 value (e.g. 20.000 mA)
re set	<i>Reset</i>	Press Enter to access the <i>Reset</i> menu
R st Hi	<i>Reset high</i>	Press Enter to reset max display
R st Lo	<i>Reset low</i>	Press Enter to reset min display
R st HL	<i>Reset high & low</i>	Press Enter to reset max & min displays
R st t	<i>Reset total</i>	Press Enter to reset total
R st Gt	<i>Reset grand total</i>	Press Enter to reset grand total
R st bc	<i>Reset batch count</i>	Press Enter to reset batch count
Con tr l	<i>Control</i>	Enter <i>Control</i> menu
Auto	<i>Automatic</i>	Press Enter to set controller for automatic operation
m An	<i>Manual</i>	Press Enter to manually control relays or analog output operation
pass	<i>Password</i>	Enter the <i>Password</i> menu
Pass 1	<i>Password 1</i>	Set or enter Password 1
Pass 2	<i>Password 2</i>	Set or enter Password 2
Pass 3	<i>Password 3</i>	Set or enter Password 3
Total	<i>Total password</i>	Set or enter password for manual reset
Gtotal	<i>Grand total password</i>	Set or enter password for manual reset
non rst	<i>Non-resettable</i>	Non-resettable grand total set after entering "050873" for Gtotal password
un loc	<i>Unlocked</i>	Program password to lock controller
loc d	<i>Locked</i>	Enter password to unlock controller
999999 -999999	<i>Flashing display</i>	Overrange condition Underrange condition

1. During operation, only the STOP button will function, to stop/pause the batch. As a result, relay alarms cannot be manually reset.
2. This setting is used for level control applications. It is not appropriate if using this controller for batching applications.

Main Menu Map

The main menu consists of the most commonly used functions: *Setup, Reset, Control, and Password.*

- Press Menu button when a batch is not running to enter Programming Mode then press the Up arrow button to scroll main menu.
- Press Menu, at any time, to exit and return to Run Mode. Changes made to settings prior to pressing Enter are not saved.
- Changes to the settings are saved to memory only after pressing Enter.
- The display moves to the next menu every time a setting is accepted by pressing Enter.

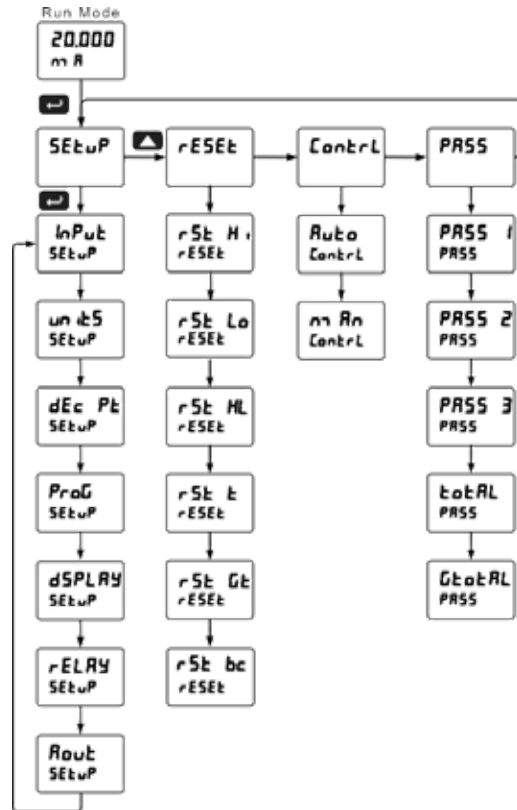

Setting Numeric Values

The numeric values are set using the Right and Up arrow buttons. Press Right arrow to select next digit and Up arrow to increment digit value.

The digit being changed is displayed brighter than the rest.

Press and hold up arrow to auto-increment the display value.

Press the Enter button, at any time, to accept a setting or Menu button to exit without saving changes.

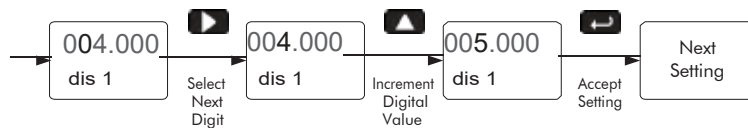

Setting Up the Batch Controller (setup)

The *Setup* menu is used to select:

1. Input signal the controller will accept
2. Enable or disable totalizer and batching features
3. Select the display units/tags
4. Decimal point position
5. Program menu for scaling or calibration
6. Display parameter and intensity
7. Relay operation
8. 4-20 mA analog output scaling

Press the Enter button to access any menu or press Up arrow button to scroll through choices. Press the Menu button to exit at any time.

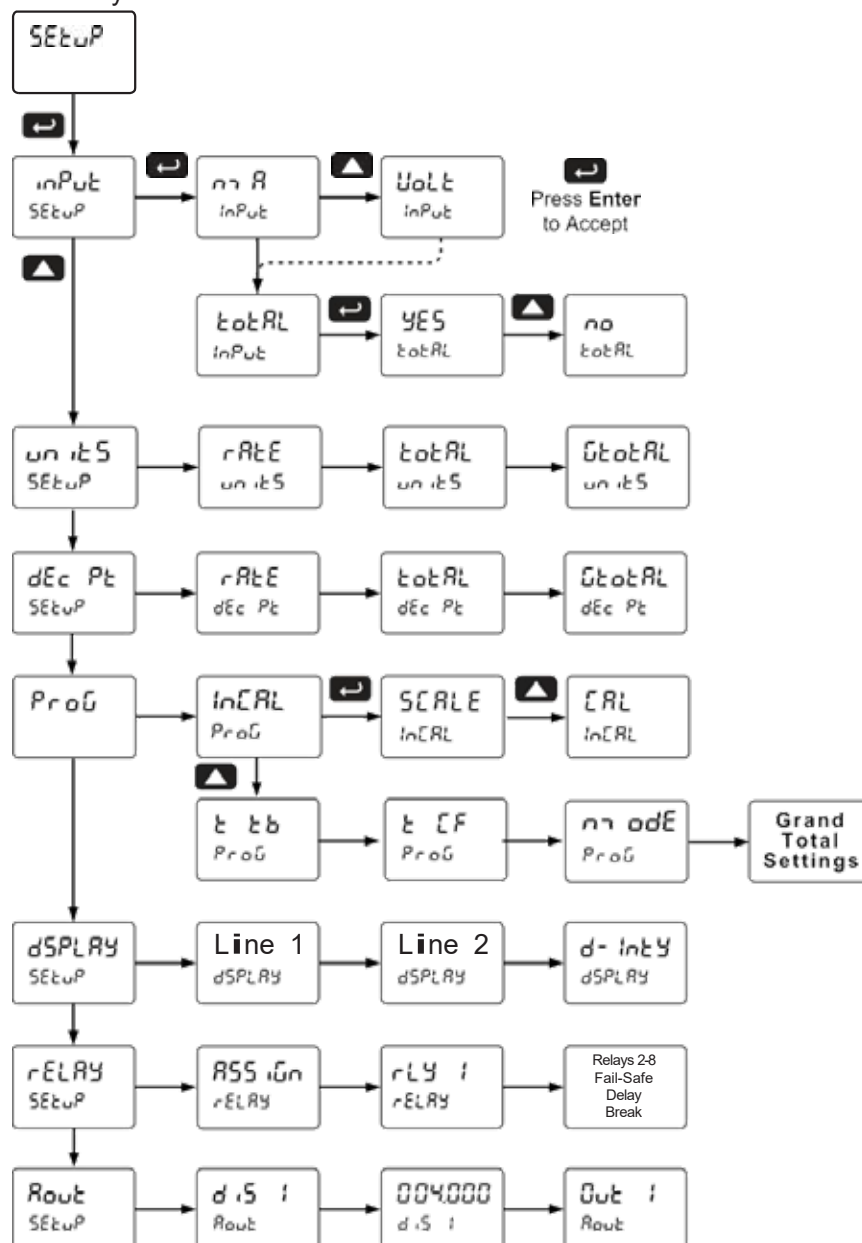

Scaling and Calibration

It is very important to read the following information, before proceeding to program the controller:

- There is **no need to recalibrate** the controller when first received from the factory.
- All inputs are factory calibrated. The calibration equipment used is traceable to NIST standards.
- Use the *Scale* menu to enter the scaling without a signal source.
- Use the *Calibrate* menu to apply a signal from a calibrator or a flowmeter for the scaling.

Setting the Input Signal (Input)

Enter the *Input* menu to set up the controller to display current (mA) or voltage (volt) inputs.

The current input is capable of accepting any signal from 0 to 20 mA. Select current input to accept 0-20 mA or 4-20 mA signals.

The voltage input is capable of accepting any signal from -10 to +10 VDC. Select voltage input to accept 0-5, 1-5, 0-10, or ±10 VDC signals.

Setting the Totalizer and Batching Features (total)

After the input type is entered, set the total parameter to “Yes” to enable batch control (this is set by default). If the total features are disabled, most batching features and functions are hidden from the menus.

Setting the Input Units or Custom Tags (units)

Enter the input unit or custom tag that will be displayed if alternating rate, total, or grand total and units is selected in the units menu, or d unit is selected as the Lower display parameter. See the flow chart on page 36 to access the display menu to show the unit or tag on the Lower display. The engineering units or custom legends can be set using the following 7-segment character set:

Display	Character
0	0
1	1
2	2
3	3
4	4
5	5
6	6
7	7
8	8
9	9
A	A
b	b

Display	Character
C	C
c	c
d	d
e	E
f	F
g	G
9	g
H	H
h	h
l	l
l	i
j	J

Display	Character
k	K
l	L
n m	m
n	n
0	O
o	o
p	P
q	q
r	r
s	S
t	t
u	u

Display	Character
v	V
uW	w
X	X
y	Y
Z	Z
-	-
/	/
[]
]	[
=	=
!	Degree(<)
	Space

Notes:

Degree symbol represented by (<) if programming with MeterView® Pro.

The letters “m” and “w” use two 7-segment LEDs each; when selected the characters to the right are shifted one position.

Press and hold up arrow to auto-scroll the characters in the display.

Setting the Decimal Point (dEc pt)

The decimal point may be set with up to five decimal places or with no decimal point at all. The rate, total, and grand total decimal points are independent.

Press the Up arrow to move the decimal point one place to the left. Press the Right arrow to move the decimal point one place to the right.

Programming the Batch Controller (prog)

It is **very important** to read the following information, before proceeding to program the controller:

- The Tek-Batch 7900A is factory calibrated prior to shipment to read in milliamps and volts depending on the input selection. The calibration equipment is traceable to NIST standards.
- Use the *Scale* menu to scale process inputs without a signal source. A calibrated signal source is not needed to scale the controller.

The *Program* menu contains the following menus:

1. Scale without a signal source
2. Calibrate with a calibrated signal source
3. Total time base & conversion factor
4. Grand total time base & conversion factor
5. Total reset mode for total & grand total

The process inputs may be calibrated or scaled to any display value within the range of the controller.

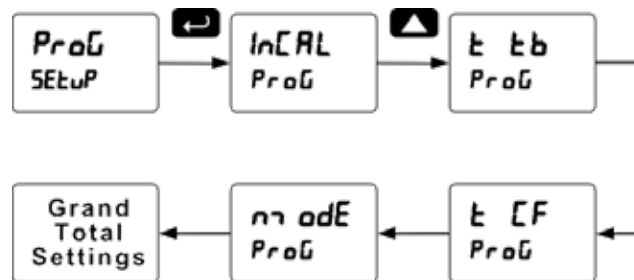

Additional parameters, not needed for most applications, are programmed in the *Advanced Features* menu; see ADVANCED OPERATION AND PROGRAMMING, page 47.

Input Calibration Method (InCAL)

There are three methods of calibrating (or scaling) the display to show the correct engineering units.

- Use the *Factor* menu to enter a K-Factor. (Pulse input models only.)
- Use the *Scale* menu to enter the scaling without a signal source.
- Use the *Calibrate* menu to apply a signal from a signal source.

Note: The K-Factor, Scale, and Calibrate functions are exclusive of each other. The meter uses the last function programmed. Only one of these methods can be employed at a time. The Scale and Calibrate functions can use up to 32 points (default is 2). The number of points should be set for Scale and Calibrate accordingly under the Number of Points (nopts) menu selection prior to scaling and calibration of the meter, see page 53 for details.

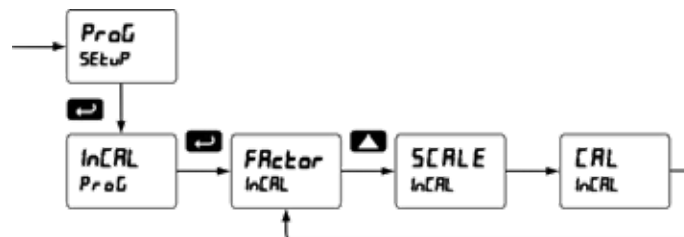

Scaling the Controller (SCALE)

The process inputs (4-20 mA and ± 10 VDC) and frequency inputs can be scaled to display the process variable in engineering units.

A signal source is not needed to scale the controller; simply program the inputs and corresponding display values.

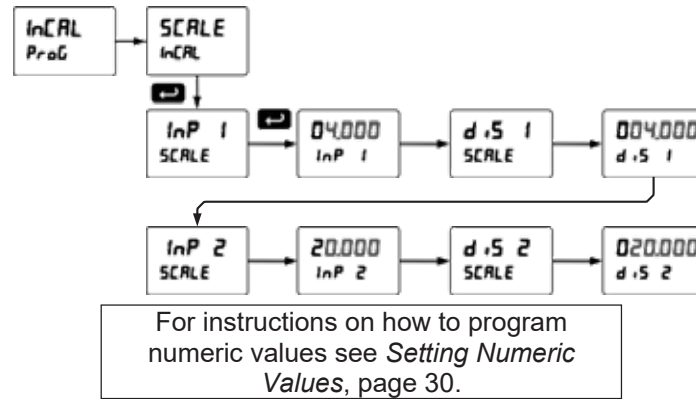

Error Message (Error)

An error message indicates that the calibration or scaling process was not successful.

After the error message is displayed, the controller reverts to input 2 during calibration or scaling and to input 1 during internal calibration, allowing the appropriate input signal to be applied or programmed.

The error message might be caused by any of the following conditions:

1. Input signal is not connected to the proper terminals or it is connected backwards.
2. Wrong signal selection in *Setup* menu.
3. Minimum input span requirements not maintained.
4. Input 1 signal inadvertently applied to calibrate input 2.

Minimum Input Span

The minimum input span is the minimum difference between input 1 and 2 signals required to complete the calibration or scaling of the controller.

Input range	Input 1 & input 2 span
4-20 mA	0.15 mA
± 10 VDC	0.01 VDC

Time Base, Total Conversion Factor & Total Reset

The time base, total conversion factor, and total reset menus are located in the *Program* menu. The total and grand total have their own independent settings. This means that one can be displaying the value in gallons while the other displays in million gallons, liters, m³, etc.

Batch Start Mode (mode)

The batch controller may operate in manual or automatic mode. In manual mode, the controller operates as defined in Controller Operation as described on page 24. In automatic mode, the batch process will automatically begin after a completed batch. The time delay for the restart may be 0.1 to 999.9 seconds (t dly). Automatic batch start will only occur after a successful batch. A manually stopped batch will require a manual start to begin a new batch process.

Grand Total Reset

The grand total can be programmed for manual or automatic reset. In the automatic reset mode, a programmable time delay is available to reset the grand total after the assigned preset is reached.

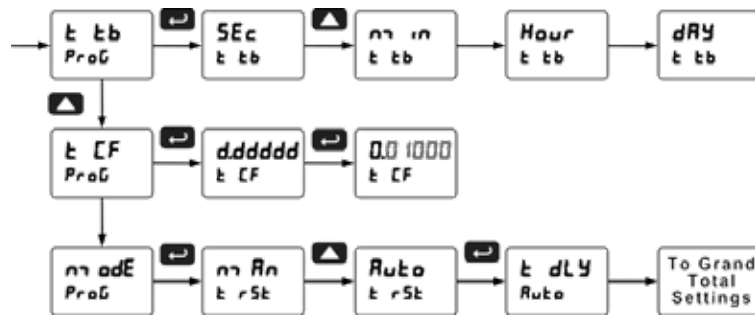

Non-Resettable Totalizer

The total and grand total can be password-protected to prevent unauthorized resets. The grand total can be programmed as a non-resettable total, see page 46 for details.

Calibrating the Controller with External Source (Cal)

To scale the controller without a signal source, refer to Scaling the Controller (SCALE) page 33.

The controller can be calibrated to display the process variable in engineering units by applying the appropriate input signal and the corresponding display value.

The use of a calibrated signal source is strongly recommended to calibrate the controller.

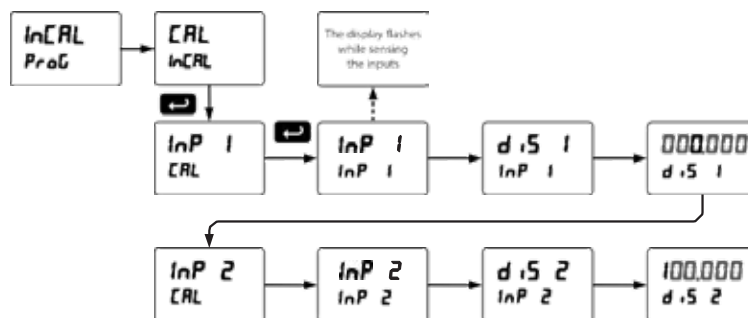

Warm up the controller for at least 15 minutes before performing calibration to ensure specified accuracy.

Setting the Display Parameter & Intensity (display)

Display line 1 (line 1) can be programmed to display:

1. Display total
2. Display grand total
3. Toggle rate and total
4. Toggle rate and grand total
5. Display batch count
6. Relay set points
7. Toggle preset and rate
8. Toggle rate and units
9. Toggle total and units
10. Toggle grand total and units
11. Display max and min values
12. Display Modbus input
13. Display rate value

Display line 2 (line 2) can be programmed to display:

1. Toggle rate and units
2. Toggle total and units
3. Toggle grand total and units
4. Display max and min values
5. Display Modbus input
6. Off (no display)
7. Display rate units
8. Display rate
9. Display total
10. Display grand total
11. Toggle rate and total
12. Toggle rate and grand total
13. Display batch count
14. Relay set points
15. Toggle preset and rate

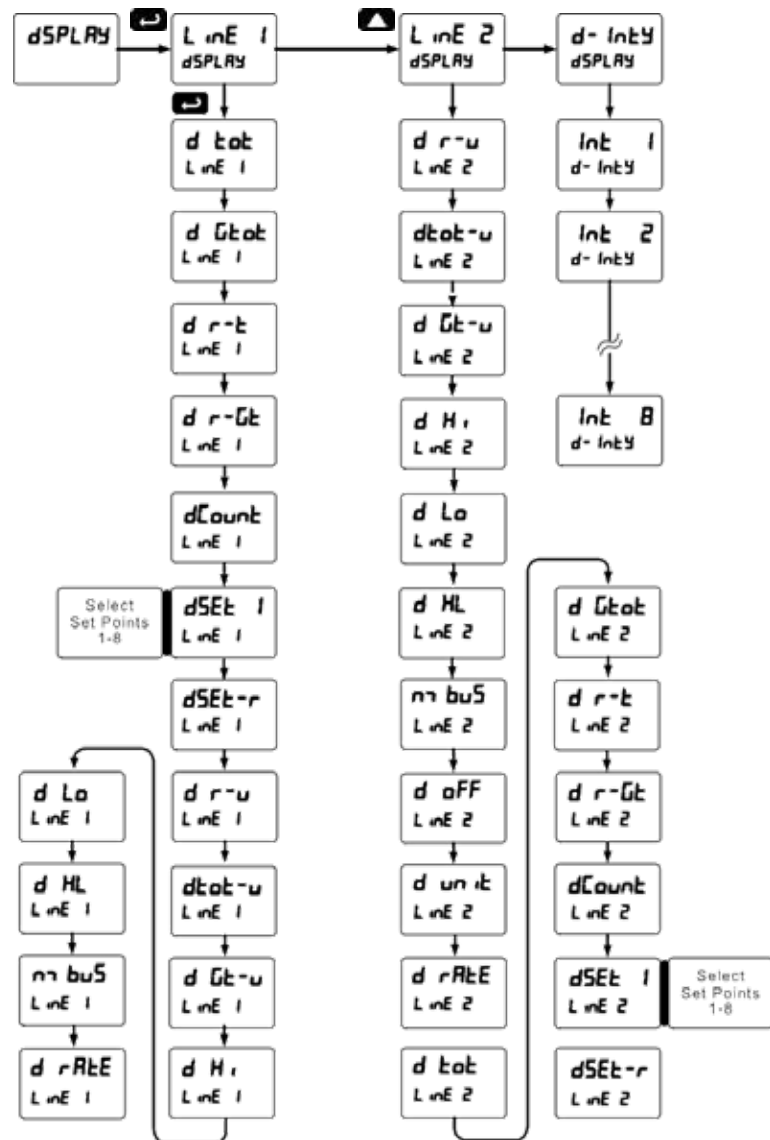

Display Intensity: The meter has eight display intensity levels to give the best performance under various lighting conditions. Select intensity 8 for outdoor applications. The default intensity setting is 8.

For direct sunlight readability, Sunbright display models are highly recommended. See Ordering Information on page 5 for details.

After setting up the input and the display, press the Menu button to exit programming and skip the rest of the setup menu. Press the Menu button again and the Up arrow to reach the *Program* menu and complete the scaling or calibration of the meter.

Setting the Relay Operation (relay)

This menu is used to set up the operation of the relays.

Caution! During setup, the relays do not follow the input and they will remain in the state found prior to entering the Relay menu.

1. Relay assignment
 - a. Rate for low and high alarm
 - b. Total for batch control relays
 - c. Grand total for grand total alarms
2. Relay action
 - a. Automatic reset only (non-latching)
 - b. Automatic + manual reset when not in a batch process (non-latching)
 - c. Latching (manual reset when not in a batch process only)
 - d. Latching with Clear (manual reset when not in a batch process only after alarm condition has cleared)
 - e. Pump alternation control (automatic reset only, for level applications unrelated to batch control)
 - f. Sampling (the relay is activated for a user-specified time and may be assigned to rate or grand total)
 - g. Off (relay state controlled by Interlock feature)
3. Set and reset points; batch preset
4. Fail-safe operation
 - a. On (enabled)
 - b. Off (disabled)
5. Time delay
 - a. On delay (0-999.9 seconds)
 - b. Off delay (0-999.9 seconds)
6. Relay action for loss (break) of 4-20 mA input (ignore, on, off)

Note: Fail-safe should not be used for relays assigned to batch control.

Rate Alarms Only Active During a Batch Process

The rate alarms are active only during a batch process. As a result, rate alarms should not be programmed with manual reset, as they cannot be manually reset during a batch process, the only time they are active.

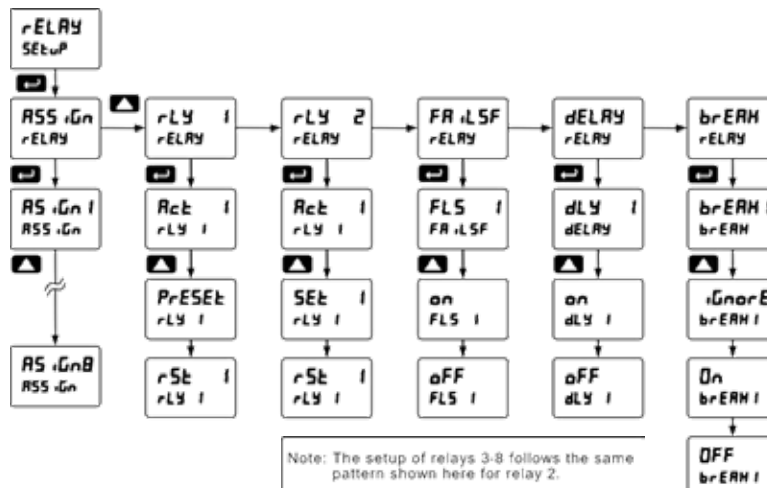

Relay Assignment (Assign)

The relays can be assigned to any of the following parameters:

1. Rate for low or high alarm indication
2. Total for batch control relays
3. Grand total for alarm indication

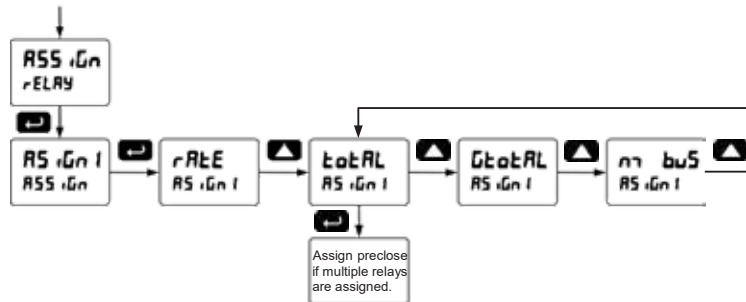

Note: Relay 1 should always be assigned to "total" for batch control applications.

Setting the Relay Action

Operation of the relays is programmed in the *Action* menu. The relays are commonly set up for any of the following modes of operation:

1. Always set to Auto for Batch control operation. Also for automatic reset (non-latching) of alarms.
2. Sampling (the relay is activated for a user-specified time)
3. Off (relay state controlled by Interlock feature)

In addition, the following relay actions may be programmed. These actions are not appropriate for batch control applications, but may be used when the controller is in other applications.

4. Automatic + manual reset when not in a batch process (non-latching)
5. Latching (manual reset only, when not in a batch process)
6. Latching with Clear (manual reset only when not in a batch process after alarm condition has cleared)
7. Pump alternation control (automatic reset only, for level applications, unrelated to batch control.)

Setting Batch Control Relays

Operation of batch control relays are programmed in the *Assign* menu by selecting *total* as the assignment. Relays set to *total* beyond the first will include a *preclose* parameter (*precls*) option. Selecting *yes* for *precls* will enable multi-stage batching with *preclose*, and the valve will close prior to the end of the batch at volume equal to the preset value minus the *preclose* amount entered. Selecting *no* for *precls* will have the relay perform identically to the first batch control relay set to *total*.

Programming Alarm Set and Reset Points

High alarm indication: program set point above reset point.

Low alarm indication: program set point below reset point.

The deadband is determined by the difference between set and reset points. Minimum deadband is one display count. If the set and reset points are programmed with the same value, the relay will reset one count below the set point.

Note: Changes are not saved until the reset point has been accepted.

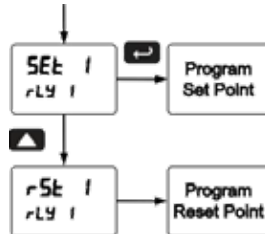

Setting Fail-Safe Operation

In fail-safe mode of operation, the relay coil is energized when the process variable is within safe limits and the relay coil is de-energized when the alarm condition exists. The fail-safe operation is set independently for each relay. Select on to enable or select off to disable fail-safe operation. Failsafe mode should not be used on batch relays assigned to total.

Programming Time Delay

The *On* and *Off* time delays may be programmed for each relay between 0 and 999.9 seconds. The relays will transfer only after the condition has been maintained for the corresponding time delay.

The *On* time delay is associated with the set point.

The *Off* time delay is associated with the reset point.

Relay Action for Loss of 4-20 mA Input (Loop Break)

The loop break feature is associated with the 4-20 mA input. Rate alarm relays may be programmed to go to one of the following conditions when the controller detects the loss of the input signal (i.e. < 0.005 mA):

1. Turn *On* (Go to alarm condition)
2. Turn *Off* (Go to non-alarm condition)
3. Ignore (Process as a low signal condition)

Note: This is not a true loop break condition; if the signal drops below 0.005 mA, it is interpreted as a "loop break" condition.

Relay Operation Details

Overview

The relays of the controller can serve three roles, as batch control relays for single or multi-stage batching, as rate, or grand total alarm, or as a sampling relay based on grand total or rate alarm. These capabilities include front panel alarm status LEDs and 2 or 4 internal relays.

The relays used for batch control (total) are activated when the batching process starts, and deactivate when the batch total is reached, minus any preclose amount programmed for batch (total) relays after the first.

For an example of batch control operation, see Batch Control Operation Example on page 25.

Typical applications for alarms are low and high flow alarms or grand total limit alarms. Note that rate alarms are only enabled during a batching process, and deactivate when the processes is stopped.

The relays can also be set for sampling, where the relay will activate for a specific amount of time after a certain grand total has been reached (ie: 2 second sample relay activation every 100 gallons batched).

There are three basic ways the relays can be used:

1. Batch Control (Total)
2. High or Low Alarms for Rate or Grand Total
3. Sampling (Based on Grand Total and Sample Time)

Relays Initialization

Batch control (total) relays will activate when the start function is enabled, such as when the START button is pressed. Rate alarm relays will enable and initialize to their programmed states when the batch process is started. Grand total alarm relays will initialize to their programmed state at controller power-up.

Fail-Safe Operation

The following table indicates how alarm relays behave based on the fail-safe selection for each relay:

Note: NO = Normally Open, NC = Normally Closed. This refers to the condition of the relay contacts when the power to the controller is off.

Fail-Safe Selection	De-Energized State		Energized State		Power Failure
	NO	NC	NO	NC	
Off	Open	Closed	Closed	Open	Relays in de-energized state
On	Closed	Open	Open	Closed	Relays in energized state

Front Panel LEDs

The LEDs on the front panel provide status indication for the following:

The controller is supplied with four alarm points that include front panel LEDs to indicate alarm conditions. This standard feature is particularly useful for alarm applications that require visual-only indication. The LEDs are controlled by the set and reset points programmed by the user. When the display reaches a set point for a high or low alarm, the corresponding alarm LED will turn on. When the display returns to the reset point the LED will go off. Note that rate alarms are only enabled during a batching process, and deactivate when the processes are stopped.

LED	Status
1	Alarm 1
2	Alarm 2
3	Alarm 3
4	Alarm 4

LED	Status
5	Alarm 5
6	Alarm 6
7	Alarm 7
8	Alarm 8

Latching relays, or relays with manual reset, are not recommended when using this controller for batch control, as the manual reset will not be acknowledged during a batch process, when the rate alarms are active.

Automatic Reset (Auto)

In this application, the controller is set up for automatic reset (non-latching relay). Acknowledging the alarm while it is still present has no effect on either the LED or the relay. When the alarm finally goes away, the relay automatically resets and the LED also goes off.

Automatic reset only		
Condition	LED	Relay
Normal	Off	Off
Alarm	On	On
Ack (No effect)	On	On
Normal	Off	Off

Pump Alternation Control

Pump alternation control is not recommended when using this controller for batch control, as it is used only in level applications, and not with rate, total, or batching applications. For information on using pump alternation control for level, see the PD6200 and PD6300 instruction manuals available at www.predig.com.

Setting Up the Interlock Relay (Force On) Feature

Relays 1-4 can be set up as interlock relays. To set up the relays for the interlock feature:

1. Access the *Setup – Relay – Action* menu and set the action to off.

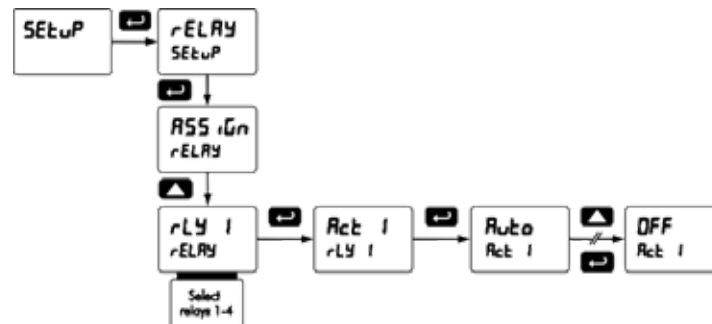

2. In the Advanced features – *User* menu program any of the digital inputs to Force On any of the internal relays (1-4).

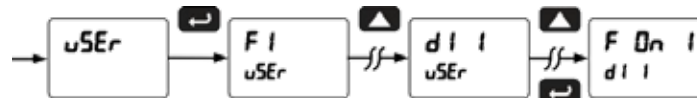

3. Connect a switch or dry contact between the +5V terminal and the corresponding digital input (di-1 to di-4) terminal.

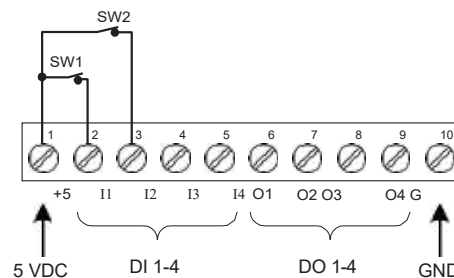

Interlock Relay Operation Example

Relays 3 & 4 are configured to energize (their front panel LEDs are off) when SW1 & SW2 switches (above) are closed. If the contacts to these digital inputs are opened, the corresponding front panel LEDs flash indicating this condition. The processes being controlled by the interlock relay will stop, and will restart only after the interlock relay is re-activated by the digital inputs (switches).

Sample Relay Operation

The sampling function allows the operator to set a set point for a “sampling” relay. This can be done for the rate, total, or grand total. Each time the relay reaches the set point, it will close that relay’s contacts for a programmed period of time

A rate sampling relay will activate for the sample time (sam t), up to 600.0 seconds, every time the set point rate is reached.

A total sampling relay will activate for the sample time (sam t), up to 600.0 seconds every time the process has batched the amount programmed for the set point, and every time this amount has been batched afterward. (See the diagram below for more details). The utility of this function can, of course, be expanded beyond sampling and be used whenever a timed relay output closure is required when the batch total interval reaches a certain set point.

Relay and Alarm Operation Diagrams

The following graphs illustrate the common operation of the relays, status LEDs, and ACK button.

High Alarm Operation (Set > Reset)

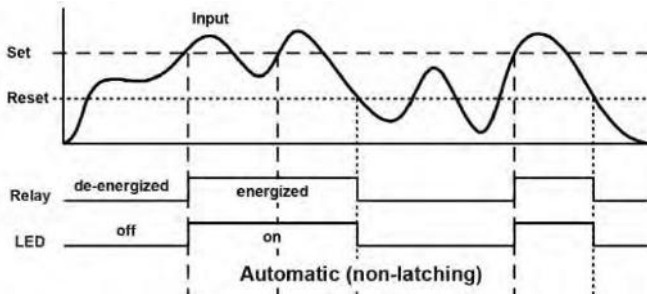

Low Alarm Operation (Set < Reset)

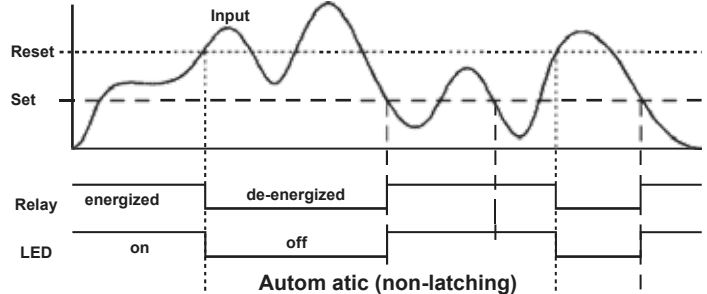

High Alarm with Fail-Safe Operation (Set > Reset)

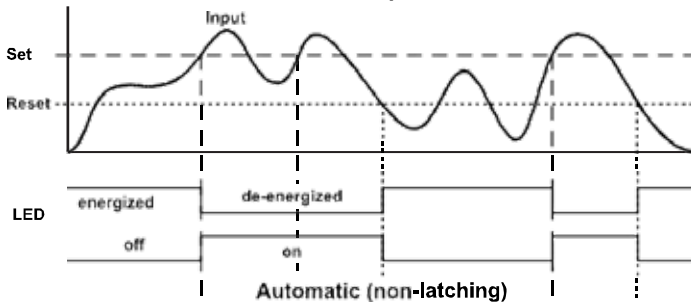

*Note: Relay coil is energized in non-alarm condition.
In case of power failure, relay will go to alarm state.*

Low Alarm with Fail-Safe Operation (Set < Reset)

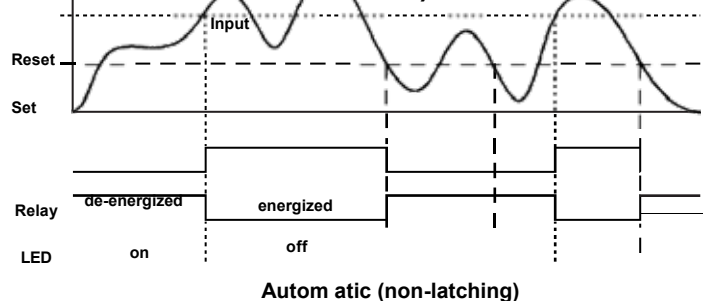

*Note: Relay coil is energized in non-alarm condition.
In case of power failure, relay will go to alarm state.*

Rate Relay Sampling Operation

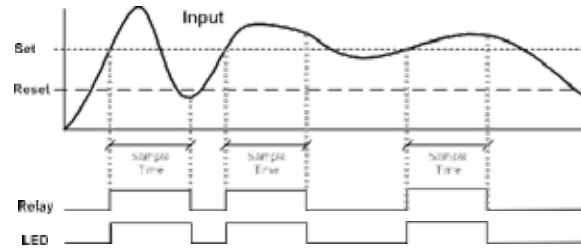

When the signal crosses the set point, the relay trips and the sample time starts. After the sample time has elapsed, the relay resets. The cycle repeats every time the set point is crossed, going up for high alarms and going down for low alarms.

The sample time can be programmed between 0.1 and 600.0 seconds.

Total Relay Sampling Operation

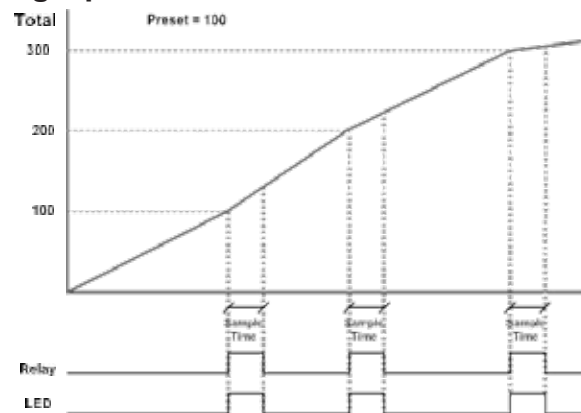

When the batch total reaches the set point, the relay trips and the sample time starts. After the sample time has elapsed, the relay resets. The cycle repeats every time the set point value is added to the batch total.

Signal Loss or Loop Break Relay Operation

The following graph shows the loop break operation for a high alarm relay.

When the controller detects a break in the 4-20 mA loop, the relay will go to one of the following selected actions:

1. Turn on (Go to alarm condition)
2. Turn off (Go to non-alarm condition)
3. Ignore (Process as a low signal condition)

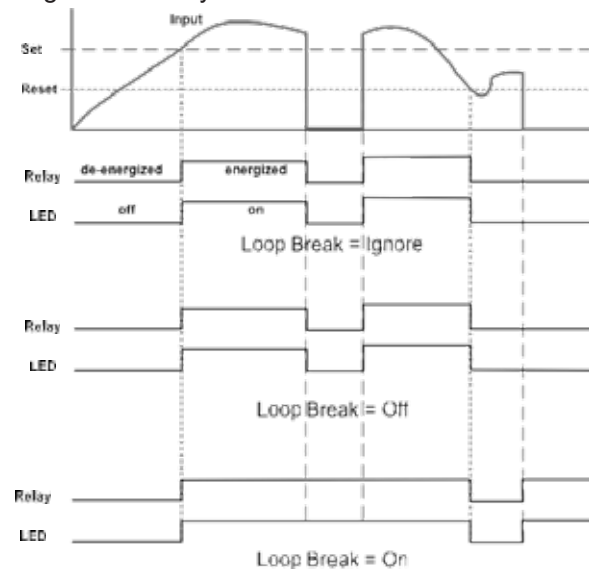

Time Delay Operation

The following graphs show the operation of the time delay function.

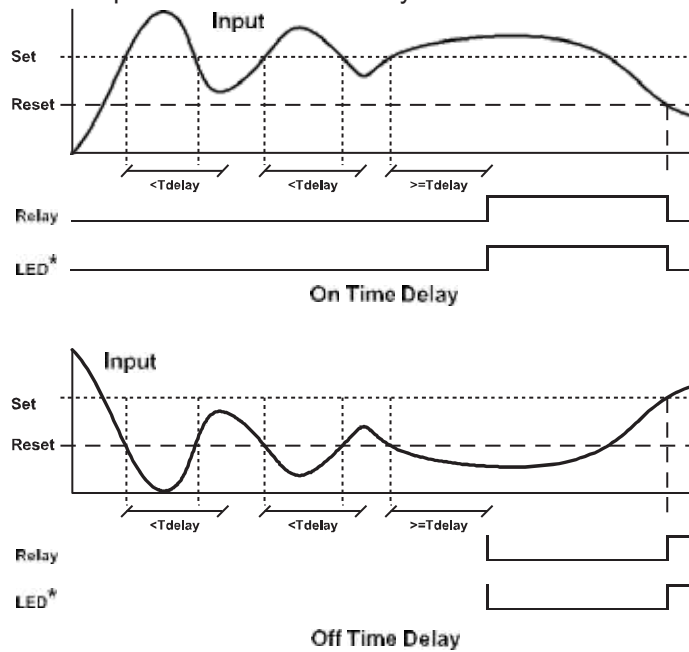

When the signal crosses the set point, the *On* time delay timer starts and the relay trips when the time delay has elapsed. If the signal drops below the set point (high alarm) before the time delay has elapsed, the *On* time delay timer resets and the relay does not change state. The same principle applies to the *Off* time delay.

Note: If "Automatic or Manual (A-mAn)" reset mode is selected, the LED follows the reset point and not the relay state when the relay is acknowledged.

Scaling the 4-20 mA Analog Output (Aout)

The 4-20 mA analog output can be scaled to provide a 4-20 mA signal for any rate display range selected.

No equipment is needed to scale the analog output; simply program the display values to the corresponding mA output signal.

The *Analog Output* menu is used to program the 4-20 mA output based on rate display values.

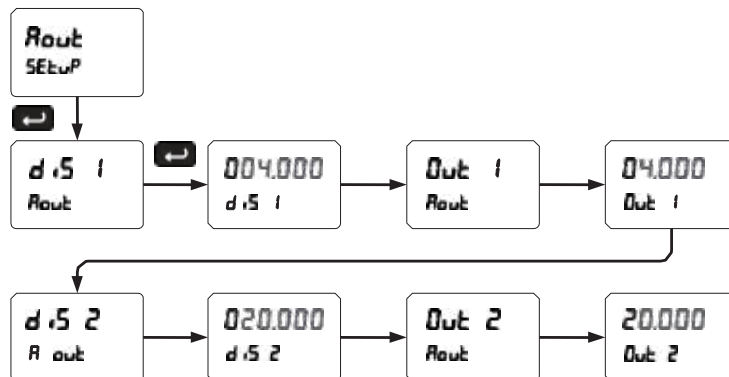

For instructions on how to program numeric values see *Setting Numeric Values*, page 30.

Reset Menu (reset)

The *Reset* menu is used to reset the total, grand totals, batch count, maximum, or minimum reading (peak or valley) reached by the process; both maximum and minimum may be reset at the same time by selecting “reset high & low” (rst HL).

Control Menu (Contrl)

The *Control* menu is used to control the 4-20 mA analog output and the relays manually, ignoring the input. Each relay and analog output can be programmed independently for manual control. Selecting automatic control sets all relays and analog output for automatic operation.

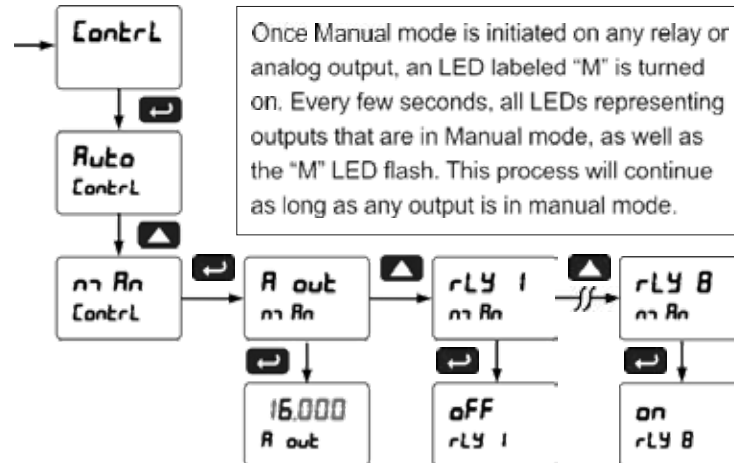

Setting Up the Password (pass)

The *Password* menu is used for programming three levels of security to prevent unauthorized changes to the programmed parameter settings and to program the non-resettable totalizer.

Pass 1: Allows use of function keys and digital inputs
 Pass 2: Allows use of function keys, digital inputs and editing set/reset points
 Pass 3: Restricts all programming, function keys, and digital inputs.
 Total Password: Prevents resetting the total manually
 Gtotal Password: Prevents resetting the grand total manually

Protecting or Locking the Controller

Enter the *Password* menu and program a six-digit password.

For instructions on how to program numeric values see *Setting Numeric Values*, page 30.

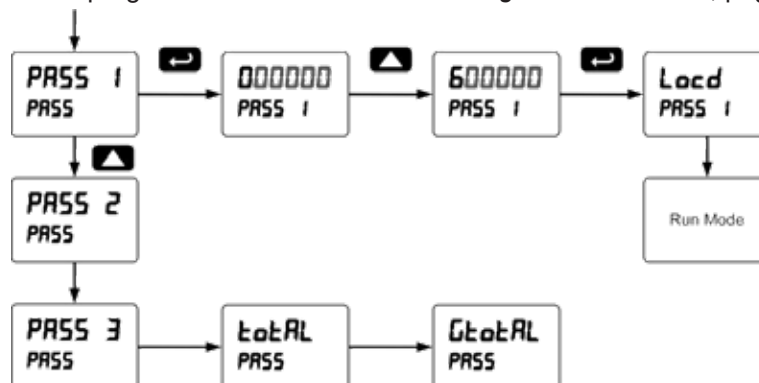

Grand Total Reset Password & Non-Resettable Total

The grand total can be password-protected to prevent unauthorized total resets.

The grand total can be programmed as a non-resettable total by entering the password "050873".

Caution! Once the Grand Total has been programmed as "non-resettable" the feature **cannot** be disabled.

Making Changes to a Password Protected Controller

If the controller is password protected, the controller will display the message *Locd* (*Locked*) when the Menu button is pressed. Press the Enter button while the message is being displayed and enter the correct password to gain access the menu. After exiting the programming mode, the controller returns to its password protected condition.

Disabling Password Protection

To disable the password protection, access the *Password* menu and enter the correct password twice, as shown below. The controller is now unprotected until a new password is entered.

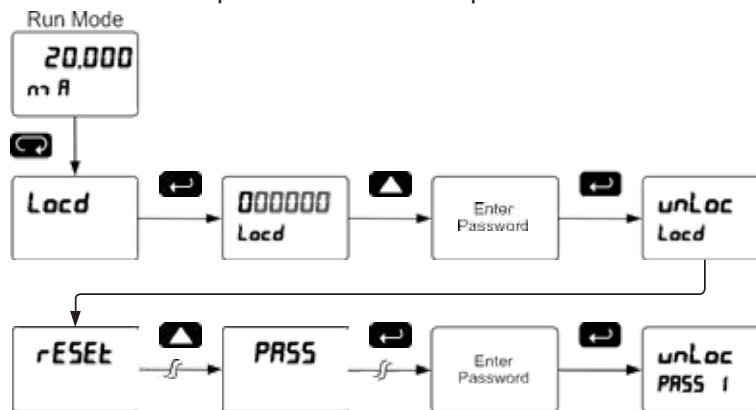

If the correct six-digit password is entered, the controller displays the message *unLoc* (unlocked) and the protection is disabled until a new password is programmed.

If the password entered is incorrect, the controller displays the message *Locd* (*Locked*) for about two seconds, and then it returns to Run Mode. To try again, press Enter while the *Locked* message is displayed.

Did you forget the password?

The password may be disabled by entering a master password once. If you are authorized to make changes, enter the master password 508655 to unlock the controller.

Advanced Operation and Programming

In addition to the functions described in Controller Operation on page 24, the following advanced operation and display features may be programmed. Configuring these features may disable some default batch controller features, or make running a batch operation impossible. These functions should only be used by users who are sure of their need in their application.

Advanced Features Menu

To simplify the setup process, functions not needed for most applications are located in the *Advanced Features* menu.

Press and hold the Menu button for three seconds to access the advanced features of the controller. This cannot be done during a batch process as all functions other than STOP are disabled during a batch process, including the Menu button.

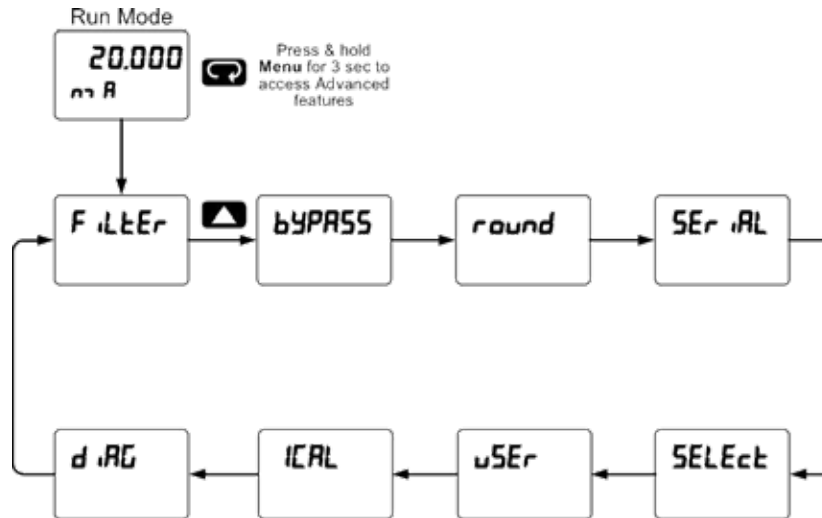

Advanced Features Menu & Display Messages

The following table shows the functions and messages of the *Advanced Features* menu in the order they appear in the menu.

Display	Parameter	Action/Setting
Lo G	<i>Low gate</i>	Program Low gate value
Hi G	<i>High gate</i>	Program High gate value
filter	<i>Filter</i>	Set noise filter value
Hi spd	<i>High Speed Filter</i>	Program High Speed Filter
Lo spd	<i>Low Speed Filter</i>	Program Low Speed Filter
bypASs	<i>Bypass</i>	Set filter bypass value
Round	<i>Round</i>	Set the rounding value for display variables
seriAl	<i>Serial</i>	Set serial communication parameters
SlaveID	<i>Slave ID</i>	Set slave ID or controller address
baud	<i>Baud rate</i>	Select baud rate
Tr dLY	<i>Transmit delay</i>	Set transmit delay for serial communication
Parity	<i>Parity</i>	Select parity Even, Odd, or None with 1 or 2 stop bits
t-byt	<i>Time byte</i>	Set byte-to-byte timeout
SeLEct	<i>Select</i>	Enter the Select menu (function, cutoff, out)
Functn	<i>Signal Input Conditioning</i>	Select linear, square root, or programmable exponent
Linear	<i>Linear</i>	Set controller for linear function and select number of linearization points
No PtS	<i>Number of points</i>	Set controller for 2 to 32-point linearization
Square	<i>Square root</i>	Set controller for square root extraction
Prog E	<i>Programmable exponent</i>	Set controller for programmable exponent and enter exponent value
CutoffF	<i>Cutoff</i>	Set low-flow cutoff
Count	<i>Count</i>	Set the totals to count up or down from a set value
Tot C	<i>Total count</i>	Set the batch to count up to or down from the preset
up	<i>Up</i>	Set the total to count up

Display	Parameter	Action/Setting
Down	<i>Down</i>	Set the total to count down
Gtot C	<i>Grand total count</i>	Set the grand total to count up or down from a defined value
C strt	<i>Count start</i>	Set the starting grand total value when counting down
AoutPr	<i>Analog output programming</i>	Program analog output parameters
Source	<i>Source</i>	Select source for the 4-20 mA output
0-rang	<i>Overrange</i>	Program mA output for display overrange
u-rang	<i>Underrange</i>	Program mA output for display underrange
Break	<i>Loop Break</i>	Set relay condition if loop break detected
Force	<i>Force output</i>	Force analog output value for loop break
Ignore	<i>Ignore</i>	Ignore loop break condition
nmAx	<i>Maximum</i>	Program maximum mA output allowed
nmIn	<i>Minimum</i>	Program minimum mA output allowed
Calib	<i>Calibrate</i>	Calibrate 4-20 mA output (internal reference source used for scaling the output)
4 nmA	<i>4 mA output</i>	Enter mA output value read by milliamp meter with at least 0.001 mA resolution
20 nmA	<i>20 mA output</i>	Enter mA output value read by milliamp meter with at least 0.001 mA resolution
user	<i>User I/O</i>	Assign function keys and digital I/O
F1	<i>F1 function key</i>	Assign F1 function key
F2	<i>F2 function key</i>	Assign F2 function key
F3	<i>F3 function key</i>	Assign F3 function key

Display	Parameter	Action/Setting
F4	<i>F4 function</i>	Assign F4 function (digital input)
dI 1	<i>Digital input 1</i>	Assign digital input 1 – 4
dO 1	<i>Digital output 1</i>	Assign digital output 1 – 4
ICal	<i>Internal source calibration</i>	Enter internal source calibration (used for scaling the controller without a signal source)
C CAL	<i>Current calibration</i>	Calibrating 4-20 mA current input (internal reference source used for scaling the input)
C lo	<i>Current low</i>	Calibrate low current input (e.g. 4 mA)

Display	Parameter	Action/Setting
C Hi	<i>Current high</i>	Calibrate high current input (e.g. 20 mA)
v CAL	<i>Voltage calibration</i>	Calibrating voltage input
v Lo	<i>Voltage low</i>	Calibrate low voltage input (e.g. 0 V)
v Hi	<i>Voltage high</i>	Calibrate high voltage input (e.g. 10 V)
Diag	<i>Diagnostics</i>	Display parameter settings
LED t	<i>LED test</i>	Test all LEDs
Info	<i>Information</i>	Display software information
erase	<i>Erase</i>	Erase MeterView Pro software stored in meter's memory

Function Keys Operation

During operation, the programmable function keys operate according to the way they have been programmed in the *Advanced Features – User* menu. The following table shows the default setting for each of the function keys.

Function Key/Button	Default Setting	Action
F1/START	Start	Start batch
F2/BATCH	preset	Change preset
F3/STOP	stop	Pause/stop batch
F4/Digital Input	Srtstp	Start/stop batch

F4 Operation

A digital input, F4, is standard on the meter. This digital input is programmed identically to function keys F1, F2, and F3. The input is triggered with a contact closure to COM, or with an active low signal. During operation, F4 operates according to the way it has been programmed in the *Advanced Features – User* menu.

Only STOP Operation Enabled if a Batch is Running.

During a batch process, the only function that can be performed is the pause/stop functions of the STOP button; the default programming of the F3 key. No other functions, including min/max display, manual alarm reset, or total reset, will function while a batch is running.

Advanced Setup and Calibration

Multi-Point Calibration & Scaling

The controller is set up at the factory for 2-point linear calibration. The number of points for multi-point calibration/scaling is set up in the *Advanced Features* menu. Up to 32 linearization points may be selected. See page 53 for details.

Maximum/Minimum Readings

The max & min readings (peak & valley) reached by the process can be displayed either continuously or momentary:

1. Display briefly by assigning to the digital inputs in the *User* menu.
2. Display continuously by assigning either display to max/min through the *Display* menu.

Changing the programming of the F1-F3 function keys will disable the default batch operation of these keys, and is not recommended for batch control applications.

Any of the digital inputs can be programmed to reset the max & min readings.

To display max/min readings continuously:

Assign either display to Max (d Hi), Min (d Lo), or toggle between Max and Min (d HL) every 10 seconds.

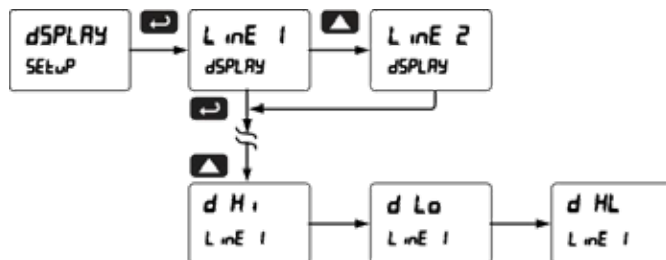

Note that changing default the programming of the upper or lower displays will interfere with seeing the batch total (upper display) or rate (lower display) of the batch process.

Noise Filter (filter)

The noise filter is available for unusually noisy signals that cause an unstable process variable display. The noise filter averages the input signal over a certain period. The filter level determines the length of time over which the signal is averaged. The filter level can be set between 2 and 199. The higher the filter level, the longer the averaging time and so the longer it takes the display to settle to its final value. Setting the filter level to zero disables the filter function.

Noise Filter Bypass (bypass)

The noise filter bypass changes the behavior of the controller so that small variations in the signal are filtered out but large abrupt changes in the input signal are displayed immediately. The bypass value determines the minimum amount of signal change to be displayed immediately. All signal changes smaller than the bypass value are filtered or averaged by the controller. The noise filter bypass may be set between 0.1 and 99.9% of full scale.

Rounding Feature (round)

The rounding feature is used to give the user a steadier display with fluctuating signals. Rounding is used in addition to the filter function.

Rounding causes the display to round to the nearest value according to the rounding selected. This setting affects the last two digits, regardless of decimal point position.

Modbus RTU Serial Communications (serial)

The controller is equipped with serial communications capability as a standard feature using Modbus RTU Serial Communication Protocol.

The meter may be connected to a PC for initial configuration via the onboard micro USB connection. For ongoing digital communications with a computer or other data terminal equipment, an RS-232, or RS-485 option is required; see *Ordering Information* on page 5 for details.

 Warning!	Do not connect any equipment other than Tek-Batch's expansion modules, cables, or controllers to the RJ45 M-LINK connector. Otherwise damage will occur to the equipment and the controller.
--	---

Note: More detailed instructions are provided with each optional serial communications adapter. Note: Refer to the ProVu® Modbus Register Tables located at www.predig.com for details.

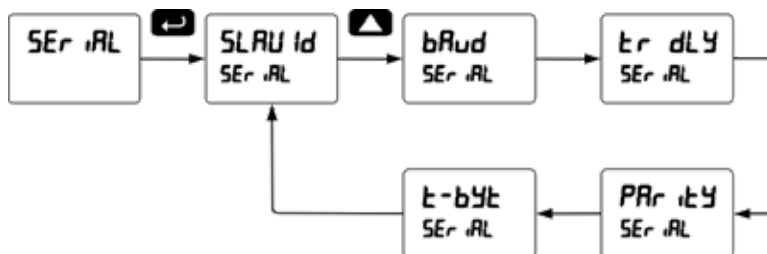

When using more than one controller in a multi-drop mode, each controller must be provided with its own unique address. The controller address (Slave ID) may be programmed between 1 and 247. The transmit delay may be set between 0 and 199 ms. The parity can be set to even, odd, or none with 1 or 2 stop bits.

Serial Communications Overview

RS-232 and RS-485 are standard interfaces approved by the Electronic Industries Alliance (EIA) for connecting serial devices. In EIA terms, the device (e.g. meter) that connects to the interface is called a Data Communications Equipment (DCE) and the device to which it connects (e.g. the computer) is called a Data Terminal Equipment (DTE).

RS-485 can support multi-point connections per line because it uses lower-impedance drivers and receivers.

Line drivers and receivers are used to exchange data between two or more points (nodes) on a serial communications network. Reliable data communications can be difficult in the presence of induced noise, ground level differences, and other hazards associated with installation of a network. When communicating at high data rates, or over long distances in real world environments, RS-232 is often inadequate. The differential data transmission of RS-485 offers superior performance in most applications. Differential signals can help nullify the effects of ground shifts and induced noise signals that can appear as common mode voltages on a network.

A multi-point network consists of multiple drivers and receivers connected on a single bus, where any point (node) can transmit and/or receive data. RS-485 allows multiple drivers and receivers on the same two-wire or four-wire system. The RS-485 standard specifies up to 32 drivers and 32 receivers on a single bus, but with the introduction of "automatic" repeaters and high-impedance drivers/receivers, this number can be extended to hundreds of points (nodes) on a network.

The cabling used for an RS-485 serial communications network should always be a high quality cable such as Belden 8162 or Alpha 6203C. A two-wire system requires two twisted pairs, and a four-wire system requires three twisted pairs (the extra twisted pair is needed for the signal ground).

Figure 19 illustrates how to connect a general four-wire network (a four-wire network actually contains 5 wires).

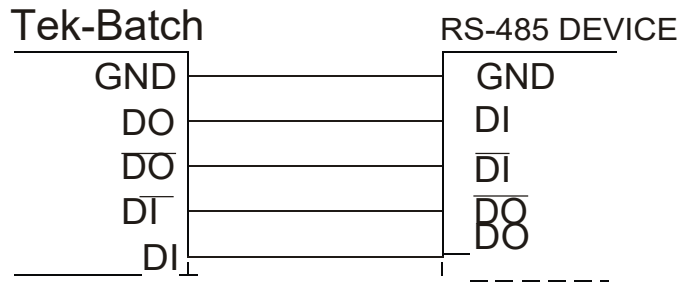

Figure 19: General Four-Wire Network Connection

Figure 20 illustrates how to connect a general two-wire network (a two-wire network actually contains 3 wires). Note that the Tek-Batch 7900A has DIP switches that allow for two-wire connections with-out the need to externally wire the DO to the DI and the /DO to the /DI (see the converter section for complete details).

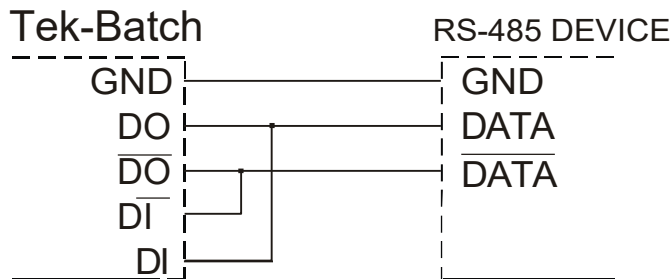
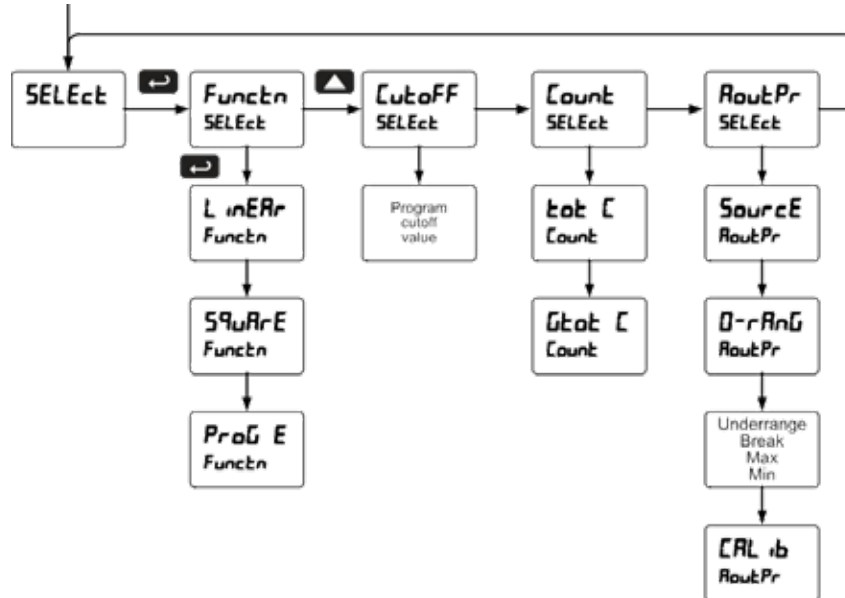

Figure 20: General Two-Wire Network Connection

Select Menu (SELEct)

The *Select* menu is used to select the signal input conditioning applied to the input (linear, square root, or programmable exponent, low-flow cutoff, and analog output programming). The multi-point linearization is part of the linear function selection.



Signal Conditioning Selection (Functn)

The *Function* menu is used to select the signal conditioning function applied to the input: linear, square root, or programmable exponent. The multi-point linearization is part of the linear function selection. Controllers are set up at the factory for linear function with 2-point linearization. The linear function provides a display that is linear with respect to the input signal.

Square Root Linearization (Square)

The square root function can be used to linearize the signal from a differential pressure transmitter and display flow rate in engineering units.

Programmable Exponent Linearization (Prog E)

The programmable exponent can be used to linearize the signal from level transmitters in open-channel flow applications using weirs and flumes.

Multi-Point Linearization (Linear)

Controllers are set up at the factory for linear function with 2-point linearization. Up to 32 linearization points can be selected under the linear function. The multi-point linearization can be used to linearize the display for non-linear signals such as those from level transmitters used to measure volume in odd-shaped tanks or to convert level to flow using weirs and flumes with complex exponent.



Low-Flow Cutoff (Cutoff)

The low-flow cutoff feature allows the controller to be programmed so that the often-unsteady output from a differential pressure transmitter, at low flow rates, always displays zero on the controller.

The cutoff value may be programmed from 0 to 999999. The controller will display zero below the cutoff value. Programming the cutoff value to zero disables the cutoff feature.

Total and Grand Total Count Direction (Count)

By default, the batch total and grand total count up during batch processes. Count parameter allows this to change. When set to count down, the batch total will count down from the preset to 0. When set to count down, the grand total will count down from a set value to zero.

Analog Output Programming (AoutPr)

The *Analog Output Programming* menu is used to program the behavior of the 4-20 mA output. The following parameters and functions are programmed in this menu:

1. Source: Source for generating the 4-20 mA output (e.g. PV)
2. Overrange: Analog output value with display in overrange condition
3. Underrange: Analog output value with display in underrange condition
4. Break: Analog output value when loop break is detected
5. Max: Maximum analog output value allowed regardless of input
6. Min: Minimum analog output value allowed regardless of input
7. Calibrate: Calibrate the internal 4-20 mA source reference used to scale the 4-20 mA output

Analog Output Source

The source for generating the 4-20 mA output may be assigned to the rate/process variable, total, grand total, maximum or minimum value reached by the rate/process, one of the set points, or the Modbus PV input.

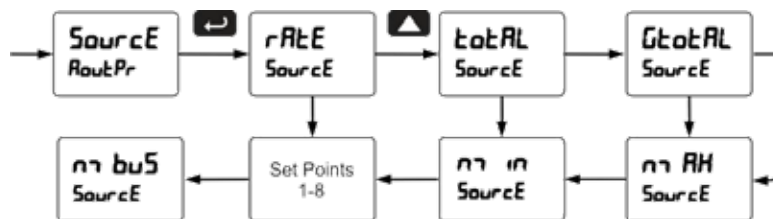

Analog Output Calibration

To perform the analog output calibration, it's recommended to use a milliamp meter with a resolution of at least 0.1 μ A to measure the output current. The values saved internally during this procedure are used for scaling the 4-20 mA output in the *Setup* menu.

Programmable Function Keys User Menu (user)

Changing the programming of the F1-F3 function keys will disable the default batch operation of these keys, and is not recommended for batch control applications.

The *User* menu allows the user to assign the front panel function keys F1, F2, and F3, the digital input F4 (a digital input located on the signal input connector), and up to eight additional digital inputs to access most of the menus or to activate certain functions immediately (e.g. reset max & min, hold relay states, etc.). This allows the meter to be greatly customized for use in specialized applications.

Up to eight digital outputs can be assigned to a number of actions and functions executed by the meter (i.e. alarms, relay acknowledgement, reset max, min, or max & min, tare, and reset tare). The digital outputs can be used to trigger external alarms or lights to indicate these specific events.

Function Keys & Digital I/O Available Settings

Refer to the following table for descriptions of each available function key or digital I/O setting.

Display	Description	Display	Description
Start	Starts the batch process	disabl	Disable the selected function key or digital I/O
Stop	Stops the batch process	ACh	Acknowledge all active relays that are in a manual operation mode such as auto-manual or latching
srtstp	Allows the same function key to both start and stop the batch process	Reset	Directly access the reset menu
Rly d	Disable all relays until a button assigned to <i>enable relays</i> (Rly E) is pressed	Rst t	Reset the total
Rly E	Enable all relays to function as they have been programmed	Rst gt	Reset the grand total
O Hold	Hold current relay states and analog output as they are until a button assigned to <i>enable relays</i> (Rly E) is pressed	Rst bc	Reset the batch count
d Hold	Hold the current display value, relay states, and analog output momentarily while the function key or digital input is active. The process value will continue to be calculated in the background.	Rst Hi	Reset the maximum display value
Ln1 Hi	Display maximum display value on line 1	Rst Lo	Reset the minimum display value
Ln1 Lo	Display minimum display value on line 1	Rst HL	Reset the maximum & minimum display values
Ln1 HL	Display maximum & minimum display values on line 1	relay	Directly access the relay menu
Ln2 Hi	Display maximum display value on line 2	preset	Change the preset value
Ln2 Lo	Display minimum display value on line 2	Set 2*	Directly access the set point menu for relay 2 (*through 8)
Ln2 HL	Display maximum & minimum display values on line 2	nmenu	Mimic the menu button functionality (digital inputs only)
Ln2 gt	Display the grand total on line 2	rigHt	Mimic the right arrow/F1 button functionality (digital inputs only)
Ln2 bc	Display the batch count on line 2	up	Mimic the up arrow/F2 button functionality (digital inputs only)
Contr	Directly access the control menu	Enter	Mimic the enter/F3 button functionality (digital inputs only)
		F On 1*	Force relay 1 (*through 4) into the on state. This function is used in conjunction with a digital input to achieve interlock functionality. See page 41 for details about interlock relays.
		Alnm 1*	Provide indication when alarm 1 (*through 8) has been triggered (digital outputs only)

Internal Source Calibration (ICAL)

Note: The Tek-Batch 7900A is factory calibrated prior to shipment to read in milliamps and volts depending on the input selection. The calibration equipment is traceable to NIST standards.

The use of a calibrated signal source is necessary to calibrate the internal source of the meter. The meter's internal source is what allows the user to scale the meter without applying a signal.

Check calibration of the controller at least every 12 months. Each input type must be recalibrated separately.

Notes:

1. If controller is in operation and it is intended to accept only one input type (e.g. 4-20 mA), recalibration of other input is not necessary.
2. Allow the controller to warm up for at least 15 minutes before performing the internal source calibration procedure.

The *Internal calibration* menu is part of the *Advanced Features* menu.

1. Press and hold the Menu button for three seconds to access the advanced features of the controller.
2. Press the Up arrow button to scroll to the *Internal calibration* menu (ICAL) and press Enter.
3. The controller displays either current calibration (C CAL) or voltage calibration (v CAL), according to the input setup. Press Enter to start the calibration process.

Example of Internal Calibration for current input:

4. The controller displays *low* input current message (C lo). Apply the low input signal and press Enter. The display flashes for a moment while the controller is accepting the low input signal.
5. After the display stops flashing, a number is displayed with the leftmost digit brighter than the rest. The bright digit is the active digit that can be changed by pressing the Up arrow button. Press the Right arrow button to move to the next digit.
6. Set the display value to correspond to the input signal being calibrated, typically 4.000 mA.
7. The display moves to the *high* input calibration (C Hi). Apply the high input signal and press Enter.
8. Set the display for the high input calibration, in the same way as it was set for the low input calibration, typically 20.000 mA.

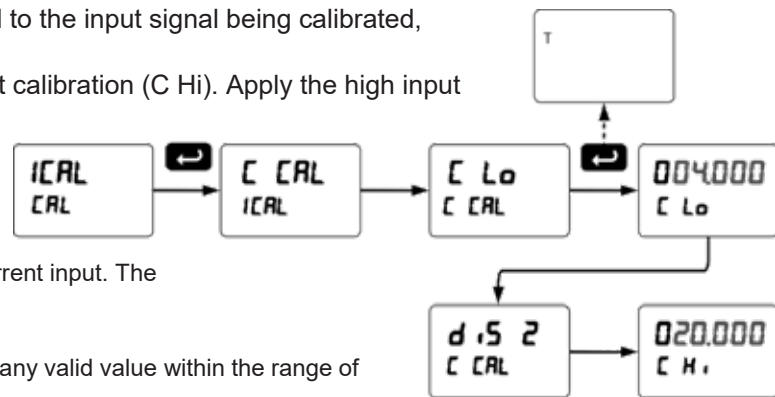

The graphic shows the calibration of the current input. The voltage input is calibrated in a similar way.

Tips:

- Low and high input signals can be any valid value within the range of the controller.
- Observe minimum input span requirements between input 1 and input 2.
- Low input should be less than high input signal.

Error Message (Error)

An error message indicates that the calibration or scaling process was not successful.

After the error message is displayed, the controller reverts to input 2 during calibration or scaling and to input 1 during internal calibration, allowing the appropriate input signal to be applied or programmed.

The error message might be caused by any of the following conditions:

1. Input signal is not connected to the proper terminals, or it is connected backwards.
2. Wrong signal selection in *Setup* menu.
3. Minimum input span requirements not maintained.

Minimum Input Span

The minimum input span is the minimum difference between input 1 and 2 signals required to complete the calibration or scaling of the controller.

Input range	Input 1 & input 2 span
4-20 mA	0.15 mA
±10 VDC	0.01 VDC

Troubleshooting

Due to the many features and functions of the controller, it's possible that the setup of the controller does not agree with what an operator expects to see.

If the controller is not working as expected, refer to the *Diagnostics* menu and recommendations below.

Diagnostics Menu (diag)

The *Diagnostics* menu is located in the *Advanced Features* menu, to access *Diagnostics* menu see *Advanced Operation and Programming*, page 47.

This menu allows the user to test the functionality of all the meter LEDs, check the meter's software and version information, and erase the MeterView Pro software installation files from the meter. Press the Enter button to view the settings and the Menu button to exit at any time.

For a description of the diagnostic messages, see *Advanced Features Menu & Display Messages*, page 48.

Determining Software Version

To determine the software version of a controller:

1. Go to the *Diagnostics* menu (diAG) and press Enter button.
2. Press Up arrow button and scroll to Information menu (Info).
3. Press Enter to access the software number (SFT) and version (UER) information. Write down the information as it is displayed. Continue pressing Enter until all the information is displayed.
4. The controller returns to Run Mode after displaying all the settings.

Reset Controller to Factory Defaults

When the parameters have been changed in a way that is difficult to determine what's happening, it might be better to start the setup process from the factory defaults.

Instructions to load factory defaults:

1. Enter the *Advanced Features* menu. See *Advanced Operation and Programming*, page 47.
2. Press Up arrow to go to *Diagnostics* menu
3. Press and hold Right arrow for three seconds, press Enter when display flashes reset.
- Note: If Enter is not pressed within three seconds, the display returns to the *Diagnostics* menu.
4. The controller goes through an initialization sequence (similar as on power-up), and loads the factory default settings.

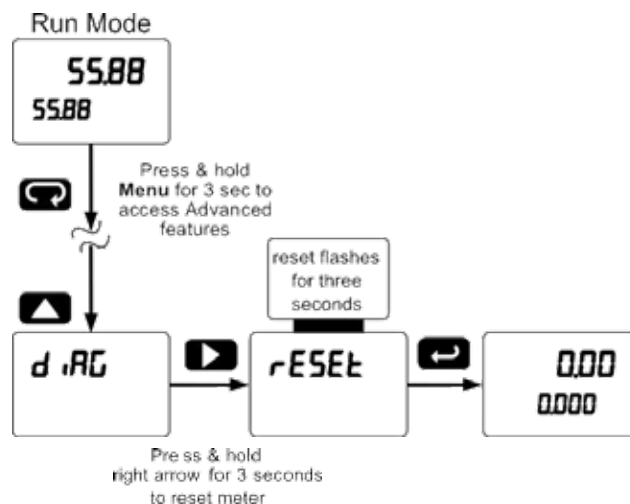

Factory Defaults & User Settings

The following table shows the factory setting for the major programmable parameters on the controller.

Parameter	Display	Default Setting	Parameter	Display	Default Setting
Input type	Input	4-20 mA	Relay 4 reset point	RSt 4	3.500
Total	yes	Total enabled	Fail-safe relay 1	FIs 1	Off
Units	units	Rate / total / gr. total mA / mA / mA	Fail-safe relay 2	FIs 2	Off
Rate decimal point	dddddd	3 Places	Fail-safe relay 3	FIs 3	Off
Total decimal point	dddddd	1 Place	Fail-safe relay 4	FIs 4	Off
G. Total decimal point	dddddd	0 Places	On delay relay 1	On 1	0.0 sec
Function	Functn	Linear	Off delay relay 1	Off 1	0.0 sec
Number of points	No Pts	2	On delay relay 2	On 2	0.0 sec
Programming	prog	Scale	Off delay relay 2	Off 2	0.0 sec
Input 1	InP 1	4.000 mA	On delay relay 3	On 3	0.0 sec
Display 1	Dis 1	4.000	Off delay relay 3	Off 3	0.0 sec
Input 2	InP 2	20.000 mA	On delay relay 4	On 4	0.0 sec
Display 2	Dis 2	20.000	Off delay relay 4	Off 4	0.0 sec
Display line 1	Line 1	Display total	Loop break relay 1	ignore	Ignore
Display line 2	Line 2	Display rate and units	Loop break relay 2	ignore	Ignore
Display intensity	d-Inty	8	Loop break relay 3	ignore	Ignore
Total time base	T tb	Second	Loop break relay 4	ignore	Ignore
Total conversion factor	T CF	1.000	Display 1 analog out	Dis 1	4.000
Batch mode	mode	Manual	Output 1 value	Out 1	4.000 mA
Grand total time base	GT tb	Second	Display 2 analog out	Dis 2	20.000
Grand total conversion factor	T CF	1.000	Output 2 value	Out 2	20.000 mA
Grand total reset	T rst	Manual	Source analog output	Source	Rate/process
Relay 1 assignment	Asign1	Total	Overrange output	0-rang	21.000 mA
Relay 2 assignment	Asign2	Total	Underrange output	u-rang	3.000 mA
Relay 2 preclose	preCls	No	Loop break output	break	1.000 mA
Relay 3 assignment	Asign3	Rate	Filter	filter	70
Relay 4 assignment	Asign4	Rate	Bypass	Bypass	0.2
Relay 1 action	Act 1	Automatic	Cutoff value	Cutoff	0.000 (disabled)
Batch preset	Preset	100.0	Maximum output	max	23.000 mA
Relay 2 action	Act 2	Automatic	Minimum output	min	1.000 mA
Relay 2 set point	Set 2	200.0	Slave ID (Address)	Slave Id	247
Relay 3 action	Act 3	Automatic	Baud rate	baud	9600
Relay 3 set point	Set 3	3.000	Transmit delay	Tr dly	50 ms
Relay 3 reset point	RSt 3	2.500	Parity	Parity	Even
Relay 4 action	Act 4	Automatic	Byte-to-byte timeout	t-byt	010 (0.1 sec)
Relay 4 set point	Set 4	4.000	F1 function key	F1	Start
			F2 function key	F2	Preset

Parameter	Display	Default Setting	Parameter	Display	Default Setting
F3 function key	F3	Stop	Password 1	Pass 1	000000 (unlocked)
F4 function	F4	Start/Stop	Password 2	Pass 2	000000 (unlocked)
Digital input 1	dI 1	Menu	Password 3	Pass 3	000000 (unlocked)
Digital input 2	dI 2	Right arrow	Total password	Total	000000 (unlocked)
Digital input 3	dI 3	Up arrow	Grand total	Gtotal	000000 (unlocked)
Digital input 4	dI 4	Enter	password		
Digital output 1-4	dO 1	Alarm 1-4			

Troubleshooting Tips

Symptom	Check/Action
SafeTouch buttons do not respond	If mechanical button was pushed. The SafeTouch buttons will be re-enabled automatically 60 seconds after the last button push. If slide switch on connector board is in DISABLE position, switch to ENABLE. Strong direct sunlight may interfere with SafeTouch button operation. It is recommended to operate the buttons by standing so as to block direct sunlight.
Serial Communications Power LED Indicator is off	<ol style="list-style-type: none"> 1. Check modular cable connection 2. Check power to the device
If only the TX (or DATA IN) data status LED is flashing when serial communications attempted	<ol style="list-style-type: none"> 1. Check serial cable 2. Check protocol selected on device 3. Check instrument address & baud rate 4. Check program address & baud rate
If both data status LEDs (TX and RX) are off when trying to communicate	Remove all unnecessary cables and instruments from the bus. Try getting the system to work with only one device (to ease troubleshooting) and then expand the system one device at a time.
Communications slow	Increase the baud rate
Random communication errors	<ol style="list-style-type: none"> 1. Increase the TX delay time 2. Decrease the baud rate
Power LED is off	<ol style="list-style-type: none"> 1. Check modular cable connection 2. Check power to instrument
No display at all	Check power at power connector
Not able to change setup or programming, Locd is displayed	Controller is password-protected, enter correct six-digit password to unlock
Controller displays error message during calibration (Error)	Check: <ol style="list-style-type: none"> 1. Signal connections 2. Input selected in <i>Setup</i> menu 3. Minimum input span requirements
Controller displays 999999 -99999	Check: <ol style="list-style-type: none"> 1. Input selected in <i>Setup</i> menu 2. Corresponding signal at Signal connector
Display is unstable	Check: <ol style="list-style-type: none"> 1. Input signal stability and value 2. Display scaling vs. input signal 3. Filter and bypass values (increase)
Display response is too slow	Check filter and bypass values
Display reading is not accurate	<ol style="list-style-type: none"> 1. Signal input conditioning selected: Linear, square root, etc. 2. Scaling or calibration

Symptom	Check/Action
Display does not respond to input changes, reading a fixed number	Check: Display assignment, it might be displaying max, min, or set point.
Display alternates between 1. Hi and a number 2. Lo and a number	Press Menu to exit max/min display readings.
Relay operation is reversed	Check: 1. Fail-safe in Setup menu 2. Wiring of relay contacts
Relay and status LED do not respond to signal	Check: 1. Relay action in Setup menu 2. Set and reset points
Flashing relay status LEDs	Relays in manual control mode or relay interlock switches opened.
Controller not communicating with application programs	Check: 1. Serial adapter and cable 2. Serial settings 3. Controller address and baud rate
If the display locks up or the controller does not respond at all	Cycle the power to reboot the microprocessor.
Other symptoms not described above	Call Technical Support for assistance.

Note: Certain sequences of events can cause unexpected results. To solve these issues, it is best to start fresh from factory defaults and map changes ahead of time, rather than at random.

Service



WARNINGS

- Installation and service should be performed only by trained service personnel. Service requiring replacement of internal sub-components must be performed at the factory.
- Disconnect from supply before opening enclosure. Keep cover tight while circuits are alive. Conduit seals must be installed within 18" (450mm) of the enclosure.
- Verify that the operating atmosphere of the instrument is consistent with the appropriate hazardous locations certifications.
- If the instrument is installed in a high voltage environment and a fault or installation error occurs, high voltage may be present on any lead
- Read all product labels completely and follow all instructions and requirements listed on the labels for installation or service.

If the enclosure is sound and undamaged, then only the internal electronics housing will need to be returned to the factory for service. Contact the factory for RMA number and return instructions.

Mounting Dimensions

All units: inches (mm)

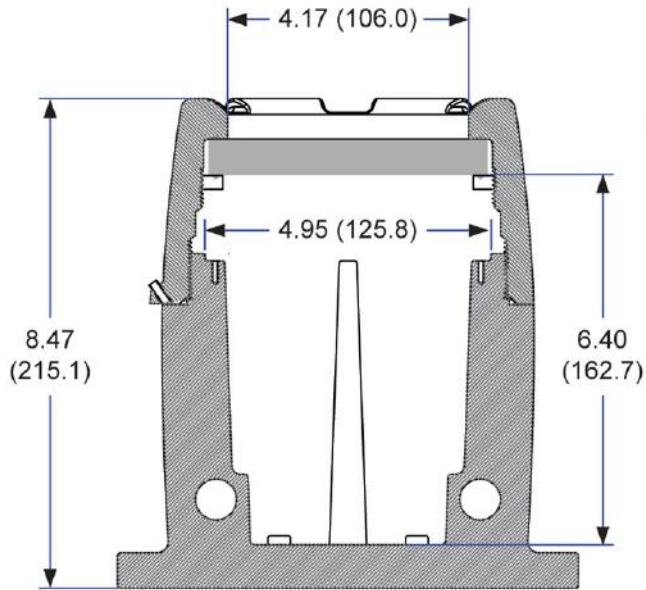

Figure 21: Enclosure Dimensions – Side Cross Section View

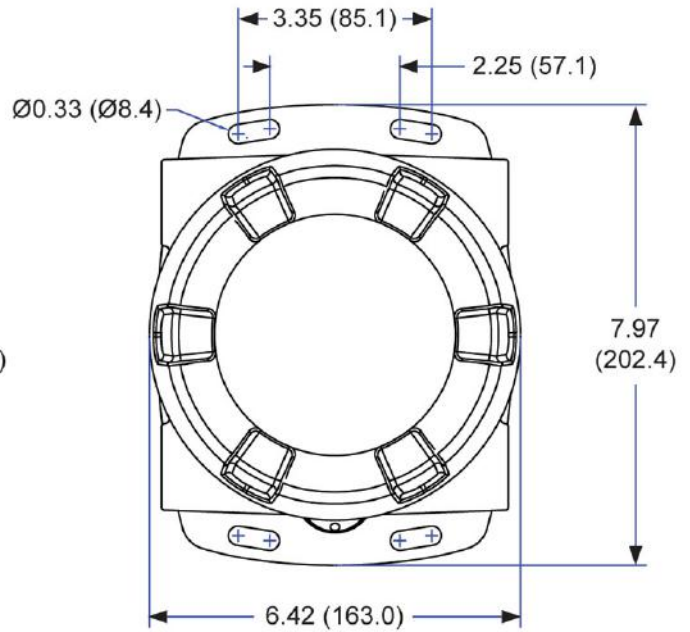

Figure 22: Enclosure Dimensions – Front View

This Page Intentionally Left Blank

How to Contact Tek-Trol Technology Solutions

- For Technical Support, please
Call: (847) 857-6076
Email: Bill@tek-trol.com
- For Sales Support or to place an order,
Call: (847) 857-6076
Email: Tektrol@tek-trol.com
- For the latest version of this manual, please visit
www.Tek-Trol.com

Tek-Trol Technology Solutions

796 Tek Drive, Crystal Lake, IL 60014
Tel (847) 857-6076



www.Tek-Trol.com



TEKMATION LLC reserves the right to change the designs and/or materials of its products without notice. The contents of this publication are the property of TEKMATON and cannot be reproduced by any other party without written permission. All rights reserved. Copyright © 2016 TEKMATON LLC
DOC:TEK1TPS/MNL/7900A/240520/r0.1
TEKMATION LLC



www.tek-trol.com

Tek-Trol is a fully owned subsidiary of TEKMATON LLC. We offer our customers a comprehensive range of products and solutions for process, power and oil & gas industries. Tek-Trol provides process measurement and control products for Flow, Level, Temperature & Pressure Measurement, Control Valves & Analyzer systems. We are present in 15 locations globally and are known for our knowledge, innovative solutions, reliable products and global presence.

Tek-Trol LLC

796 Tek Drive Crystal Lake, IL 60014 USA
Tel.: +1 847 857 6076 Fax: +1 847 655 6147
Email: tektrol@tek-trol.com
www.tek-trol.com