



Technology Solutions

TEK-DPro Flow Solutions

SMART Differential Pressure Flow Meters



FLOW

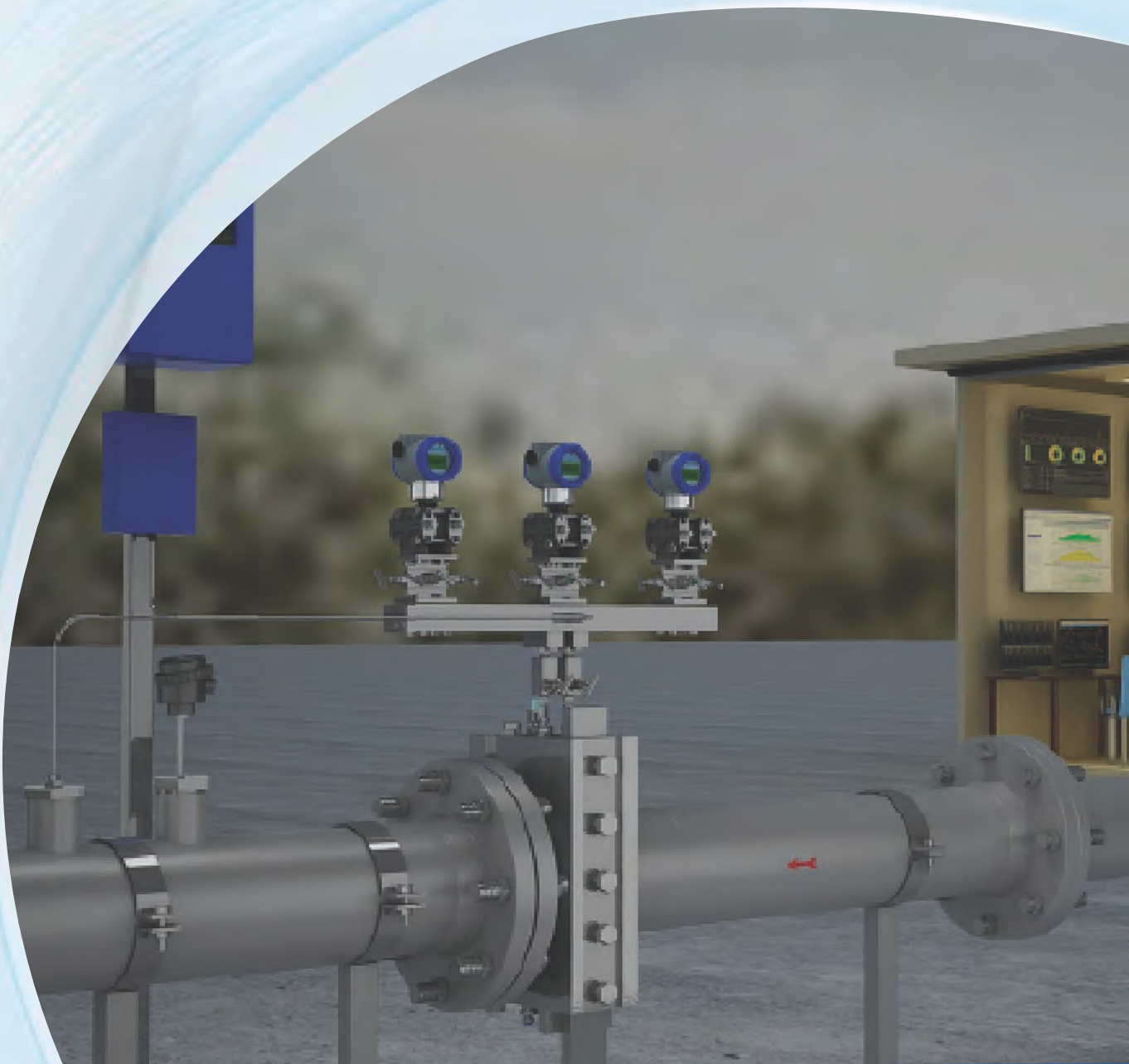

www.tek-trol.com

Flow | Level | Temperature | Pressure | Valves | Analyzers | Accessories | TekValSys

SMART Differential Pressure Flow Solutions



*Flow Computer
TekValSys FCA*



*Pressure transmitters
Tek-Bar 3110 series*



*Calibrated Meter Runs
Tek-DPro 1610C*

*Primary Elements
Tek-DPro 1600 Series*

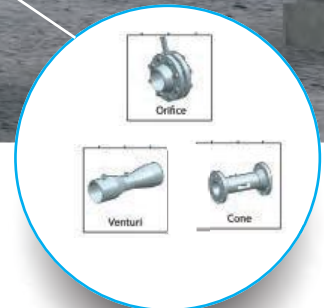

*TekValSys DPro Validation System
powered by Prognosis™*

Complete portfolio with DP Primary & Secondary flow elements

For over 100 years, Differential Pressure (DP) devices are used widely in many applications and form the largest installed base of all flow measurement devices. DP flowmeter designs are simple and sturdy, and are therefore reliable. Tek-Trol offers a comprehensive range of DP flowmeters-not just the primary elements but also the secondary transmitters and state-of-the-art DP flow monitoring and validation system, popularly known as the TekValSys DPro system.

The Tek-Trol's range of DP primary elements includes :

- Cone Meter
- Orifices (Orifice Flange Union, Single Chamber Orifice, Dual Chamber Orifice)
- Venturi Tubes
- Flow Nozzle
- Annubar/Pitot Tube
- Wedge Meters

Measuring Principle

Orifice meter works on the principle of differential pressure measurement. It is based on Bernoulli's theory of conservation of mass and energy in a closed pipe. According to this principle, obstruction to the flow of fluid leads to increase in the flow velocity (i.e. $V_2 > V_1$), thereby creating a pressure drop. The flow rate can be determined by measuring the static pressures at upstream and downstream, minimum cross sectional area and temperature. The flow rate of the fluid is calculated by applying the law of conservation of mass and energy.

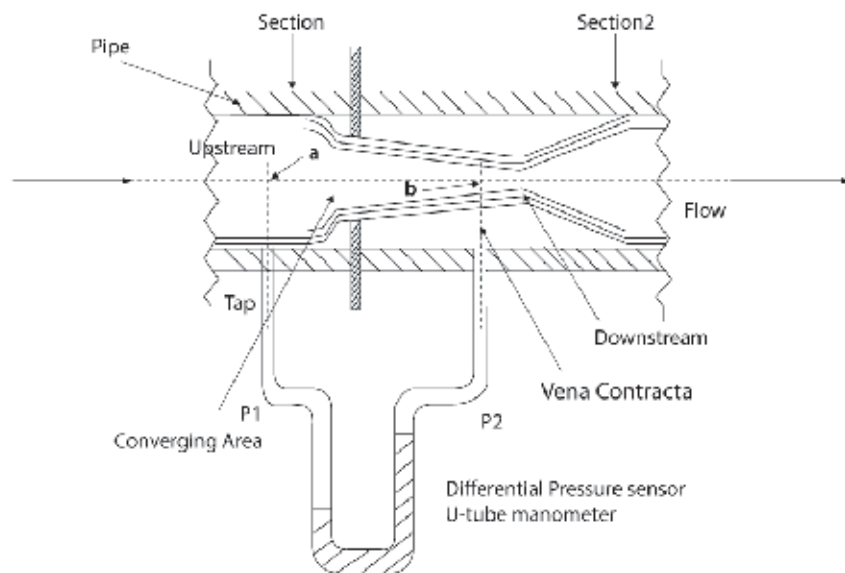

Bernoulli described this relation between differential pressure and flow rate by equation,

$$\Delta p \propto Q_m^2$$

The differential pressure generated, Δp , is proportional to the square of mass flow rate, Q_m . In simple terms, for a given size of restriction, higher the Δp , higher is the flow rate.



Tek-DPro Flo-Orifice

Designed in accordance with client specified standards including AGA, ISA, ASME, API, and ISO. Broad acceptance throughout industry due to extensive flow data and documented geometric tolerances versus stated accuracy. Low cost solution for clean, non-abrasive fluids with high Reynolds Number.

- Paddle type
- Concentric, square edge, eccentric, segmental, quadrant edge
- Bore & bevel and bore & counter bore
- Orifice Flange assemblies
- Meter runs
- Integrated Manifolds and Secondary Electronics



Tek-DPro Flo-Cone

Designed to measure flow rates for liquid and gases in tight pipe configurations where straight runs are limited. Reshapes the flow profile, can measure turbulent flows or can act as a static mixer. Popular for steam flow measurement due to static mixing of poor quality steam and lack of real estate common in power houses

- Available with ANSI or RTJ Flanges
- Wafer Style up to 3" pipe size
- Other process connections available such as threads, beveled ends for "Weld In" or Hubs
- 304SS, 316SS, Carbon Steel, and other materials on demand
- Integral Manifold and Secondary Electronics available

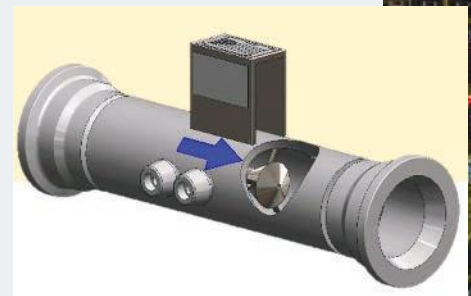



Tek-DPro Flo-Venturi

Designed to meet customer specifications and to adhere to ASME MFC-3M-2004; ISO 5157; B31.1 and B31.3. Designed to measure flow rates for fluids under extreme process conditions; high temperature and pressure, highly corrosive and/or abrasive fluids.

Works well on sticky or viscous liquids, on slurries, sludge, as well as chemicals, water, gases, air and steam.

- Classical Venturi with 21 degree Convergence and 7 degree Divergence
- Short Form Venturi with 21 degree Convergence and 15 degree Divergence
- Lo Loss Venturi with ISA 1932 Nozzle inlet and 7 or 15 degree Divergence
- Bi-Directional Designs available
- Fully Machined Convergent, Throat, and Divergent sections up to 10 inch
- Formed and welded Convergent and Divergent sections for larger pipe sizes
- ANSI and RTJ Flanges; Beveled ends for "Welded-In" designs; High Pressure Hubs
- Integral Manifolds and Secondary Electronics
- Chemical Seal instrument connections available

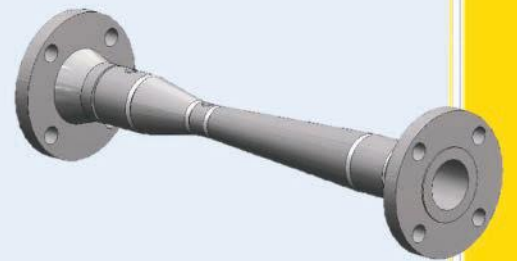

Tek-DPro Flo-Nozzle

Designed in accordance with client specified standards including ASME MFC-3M; ASME PTC-6; ISO 5167-3.2003.

Broad acceptance throughout industry due to extensive flow data combined with documented geometric tolerances that allow for proven stated accuracies.

Used in applications with high flow rates where Reynolds Numbers are in the millions. Steam, feed water and high velocity gas lines are reasons the flow nozzle is a popular choice in the power industry.

- Long radius Flow Nozzles
- ISA 1932 Flow Nozzles
- Venturi Nozzles
- Weld-in and flanged-in designs
- Meter Runs
- Integrated Manifolds and Secondary Electronics





Tek-DPro Flo-Annubar

Designed to measure flow rates of clean fluids such as steam, air, gases and liquids for general purpose applications.
 Best cost/performance ratio on the market.
 High energy savings gained through minimal permanent pressure loss.
 Versatile instrument easy to install, commission and maintain.

- “WedgeBar” design prevents wear and plugging, while obtaining optimum accuracy
- “RoundBar” design for large pipe or duct sizes
- 316SS Standard Material, others available on demand
- Threaded, flanged, inline flanged, and hot tap process connections
- Integral Temperature Element Option
- Integral Manifold and Secondary Electronics available



Tek-DPro Flo-Wedge

Designed to measure flow rates for fluids under extreme process conditions; high temperature and pressure, highly viscous, corrosive and/or abrasive fluids.
 Designed to meet customer requirements and adhere to B31.1 and B31.3; RW Miller.
 Commonly used to measure slurries, sludge, as well as chemicals, water, gases, air and steam.
 The Wedge Meter has the most stable Discharge Coefficient of all the flow primaries at low Rd Numbers.

- Flanged or “Welded-In” designs
- Threaded Process connections up to 2.5”
- Wafer designs with integral instrument taps or designed to fit between Orifice Flanges
- Designs with reduced bores available for low flows
- Integral meter runs available on small bore Wedge Meters
- Carbon Steel; 304SS; 316SS and other materials on demand
- Integral Manifolds and Secondary Electronics Available
- Special flush chemical seal connections available
- Standard Wedge Meters are Bi-Directional by design

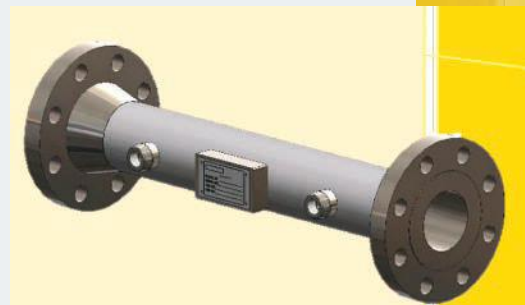

TekValSys DPro Validation System

A unique, powerful industrially-proven real time validation & monitoring system for differential pressure flowmeters



World-class configuration, service, and troubleshooting tool

- Supports all differential pressure flowmeters
- Supports all smart pressure differential transmitters
- Management and simulation of captured data points

Intuitive display of process variables and diagnostics

- Enhanced data logging functionality, both on-demand or time-based
- Graphical process variable trending views

Support for multiple devices

- Simultaneously connect to multiple primary and secondary devices
- Ideal tool for evaluating multiple devices simultaneously

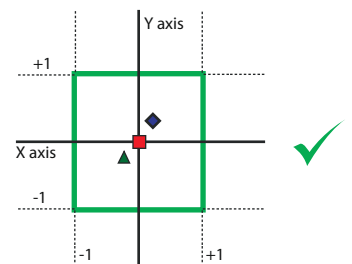

Fig: Compliance, Correct

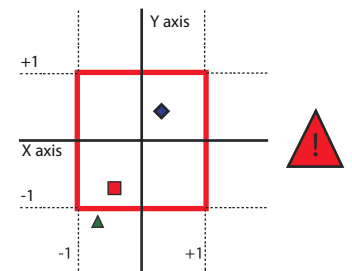

Fig: Non-Compliance, Error

TEK-DPro Flo-Mass

SMART Mass Measurement using Tek-DPro & Tek-Vor Technology

Tek-Trol's Tek-DPro Flo-Mass flowmeters utilizes two different flow meter technologies in combination; Tek-Vor, Vortex and Tek-DPro, Cone Differential Pressure. The design has blended the two separate flow metering principles into one meter body such that the two meters do not have adverse effects on each other's performance. This combination allows for the prediction of the fluid density, volumetric flow rate and mass flow rate without any fluid density information being required from an external source.

This ability to predict fluid density allows the meter to provide several valuable measurements. With wet gas and steam applications the Tek-DPro Flo-Mass meter will provide an accurate total mass flow measurement. In steam service, the meter is able to provide a reliable steam quality (steam dryness) measurement. The Tek-DPro Flo-Mass meter is also able to calculate the density of gas mixtures. For example, natural gas is typically a composition of many different gases, each with their own density. These are a few examples of the unique measurement capabilities of the Tek-DPro Flo-Mass.

With the addition of two differential pressure transmitters, the TekValSys DPro, advanced diagnostic software is able to continually monitor and verify the meter's primary element health and confirm output uncertainty. The Tek-DPro Flo-Mass line is available with a wide range of options and meter configurations to meet your specific application requirements.

Tek-DPro Flo-Mass Advantages

- Can provide a measurement of fluid density, volumetric flow rate and mass flow rate without any fluid information being required from an external source
- In steam service, the meter is able to provide a reliable steam quality (steam dryness) measurement as well as mass flow measurement
- Able to calculate the density of changing gas mixtures. For example, natural gas is typically a composition of many different gases which can vary over time and vary by application
- More cost effective than current steam quality and wet gas meters on the market.
- Advanced diagnostic software is able to continually monitor and verify the meter's primary flow element health and confirm output uncertainty
- Able to use with liquids, gases, and steam
- Multivariable options available for temperature and pressure measurement. Multiple readings from a single installed device reduces initial cost, installation cost and cost-of ownership over the lifetime of the instrument
- Mass flow equations for additional diagnostic information and verification - real gas, ideal gas, AGA 8, API 2540
- Energy Monitoring—ability to compute and output energy consumption with select fluids. Steam, water, and heat transfer fluids
- Easy to install and commission
- Reliable—no moving parts, no fluid to sensor contact
- Temperature up to 750°F
- Pressure up to 1500 psig
- Inline configuration for pipes from 2"- 12" (DN50 to DN 300)
- Field configurable ranges, outputs and displays
- Remote electronics option available for use in harsh environments or locations with limited access
- HART protocol communications - Standard
- Modbus, BACnet, Power over Ethernet (PoE) communications available

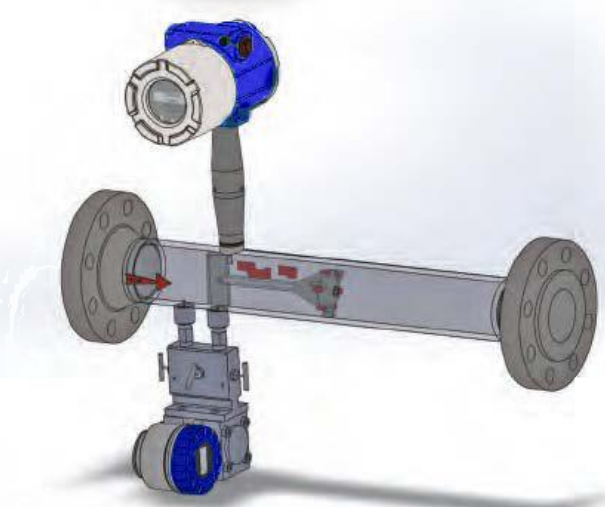

Fig. Principle of Operation

TEK-ValSys FCA

SMART Mass Measurement using Tek-ValSys FCA & Tek-Vor Technology

Tek-Trol's TekValsys FCA flow computer is a field mounted flow computer which can be used for liquid and gas applications, including custody or non-custody measurements. TekValsys FCA is the most powerful flow computer of its kind and represents some of the latest advancements in operation, performance, and modularity.

TekValsys FCA has been designed to meet the requirements of a wide variety of specialized industries using a single hardware platform thus reducing spare parts requirements, training and calibration costs, and lowers the overall cost of ownership.

When used for differential pressure applications, advanced diagnostic software is able to continually monitor and verify the meter's primary element health and confirm output uncertainty.

The TekValsys FCA product line is available with a wide range of options and configurations to meet your specific application requirements.

Tek-ValSys FCA Advantages

- Flexible design with power and communication options to meet site needs
- Custody compliant
- Local data logging capabilities
- Advanced diagnostic software can continually monitor and verify the meter's primary flow element health and confirm output uncertainty
- Advanced diagnostic software can reduce need to re-calibrate resulting in less time spent on site
- User configurable for multiple differential pressure primary flow elements. Such as: orifice, venturi, flow nozzle, wedge, cone
- Push button interface
- Volumetric or mass flow monitoring of most liquids, gases, and steam
- Mass flow equations - real gas, ideal gas, AGA 8, API 2540
- When used in conjunction with Tek-Trol's VorCone. FlowCalc can provide a measurement of fluid density, volumetric flow rate and mass flow rate without any fluid information being required from an external source
- When used in conjunction with Tek-Trol's VorCone™, TekValsys FCA can provide a reliable steam quality (steam dryness) measurement as well as mass flow measurement.
- When used in conjunction with Tek-Trol's VorCone™, TekValsys FCA can calculate the density of changing gas mixtures. For example, natural gas is typically a composition of many different gases which can vary over time and vary by application
- Energy Monitoring—ability to compute and output energy consumption with select fluids. Steam, water, and heat transfer fluids
- Low power
- Modbus, BACnet, Power over Ethernet (PoE) communications available
- HART protocol communications –Standard
- Approvals pending



Verification System

Differential Pressure Verification System – DP Health Check™ DP

Health Check is a comprehensive verification system for Differential Pressure (DP) meters. Utilizing a third pressure port downstream of the DP meter and reading three DPs, DP Health Check analyses not just the traditional single DP reading, but the entire pressure field. The additional information expands the capability of the DP meter, offering a full diagnostic suite. DP Health Check creates a smart DP meter allowing for condition based maintenance operations.

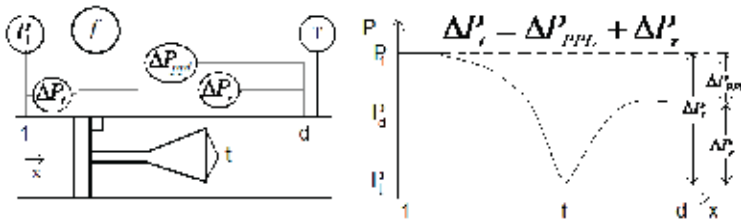

Fig 1. DP Health Check™ Ready Cone DP Meter and Associated Pressure Field

DP Health Check creates seven diagnostic checks, i.e. one DP integrity check, three separate inter-comparable flowrate predictions, and three DP ratios comparable with the baselines. The HMI (human-machine interface) is designed for simplicity: the seven diagnostics are plotted as four points on a graph with a 1x1 box. All points inside the box shows the meter is functioning normally (see Fig 2). Any points outside the box shows a potential metering issue. Figs. 3 and 4 show response to varying saturated steam quality and single phase DPt reading error respectively. Pattern recognition technology allows the source of the problem to be directly identified

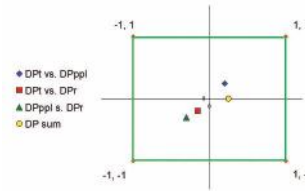

Fig 2. Display for Correctly Operating Meter

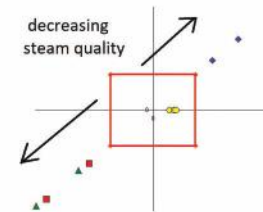

Fig 3. Display for Varying Quality Saturated Steam Flow

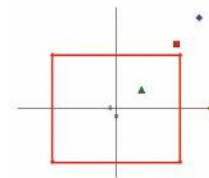

Fig 4. Display for Drifting DP Transmitter

Specifications

Ambient Temperature

Ambient Operating: -40 to 140°F (-40 to 60°C)

Ambient Storage: -40 to 185°F (-40 to 85°C)

Power Requirements

DCH option: 12-36 VDC, 300mA, 9W max

DCHPOE: 12-28 VDC or Power over Ethernet, 5 Watts maximum

Display

Alphanumeric 2 line x 16 character LCD digital display Six pushbuttons for full field configuration Pushbuttons can be operated with magnetic wand without removal of enclosure covers Display can be mounted in 90° intervals for better viewing

Input Signals

4-20mA (Flow, Pressure, Temperature)

Pulse

Frequency

RTD (Ohm)

Modbus

BACnet

Output Signals

Analog: 4-20 mA (Volumetric flow, mass flow, density, pressure, temperature)

Alarm: Solid state relay, 40 VDC

Totalizer Pulse: 50 millisecond pulse, 40 VDC

Volumetric or Loop Powered Mass: One analog, one totalizer pulse, HART

Multivariable option: Up to three analog signals, three alarms, one totalizer pulse, HART

Multivariable option: Modbus or BACnet process monitoring

CPU

Type: 32 bit 250 MHz

Flash: 8 MB

RAM: 64 MB DDR2

Approvals

Pending

Customer Service and Support



TEKMATION LLC reserves the right to change the designs and/or materials of its products without notice. The contents of this publication are the property of TEKMATON and cannot be reproduced by any other party without written permission. All rights reserved. Copyright © 2016 TEKMATON LLC
DOC # TEK/ITPS/240520/TEK-DPR0/0.1
TEKMATION LLC



www.tek-trol.com

Tek-Trol is a fully owned subsidiary of TEKMATON LLC. We offer our customers a comprehensive range of products and solutions for process, power, and oil and gas industries. Tek-Trol provides process measurement and control products for Flow, Level, Temperature and Pressure Measurement, Control Valves and Analyzer systems. We are present in 15 locations globally and are known for our knowledge, innovative solutions, reliable products, and global presence.

Tek-Trol LLC

796 Tek Drive Crystal Lake, IL 60014 USA
Tel: +1 847 857 6076 Fax: +1 847 655 6147
Email: tektrol@tek-trol.com
www.tek-trol.com