



Technology Solutions

TEK-DP 1610E

Orifice Plates



FLOW



Introduction

Orifice plates are the most commonly used devices for flow measurement in pipelines. Orifice Plates are based on the measurement principle of 'differential pressure', which is created when an obstruction is intentionally placed in the fluid flow to decrease fluid velocity. The Tek-DP 1610E Orifice Plates cover an extensive range of applications to accumulate fluid and operating conditions.

They live a long life without regular maintenance.

Tektrol's 1610E plates are manufactured in full compliance with industry standards (AGA3/API 14.3, ISO) and to meet the specific application requirements which ensures accurate measurements.

Measuring Principle

The Tek-DP 1610 E Orifice Plate uses the principle of differential pressure to measure flow. Based on Bernoulli's principle, the obstruction to the flow of fluid leads to an increase in the flow's velocity (i.e. $V_2 > V_1$), thereby creating a pressure drop. The flow rate depends on the static pressures, both at the beginning and end of a system, minimum cross-sectional area, and temperature. It is calculated by applying the law of conservation of mass and energy to.

The relation between differential pressure and flow rate is represented as the following expression

$$\Delta p \propto Q^2$$

The differential pressure generated, (Δp), is proportional to the square of mass flow rate, (Q). In simple terms, for any given size of restriction, the higher the differential pressure, (Δp), the higher the flow rate, (Q).

Benefits

- Precision machinery with superior quality
- Measurement accuracy and reliability
- Accurate flow measurement without the need for calibration
- Simple to operate and easy to troubleshoot.
- Stationary parts ensure minimal maintenance
- Easy Installation

Application

- Pipelines including transmission and distribution
- Offshore / onshore production
- Gas processing plants
- Large industrial sites

Orifice Plates and Seals



Universal Type Orifice Plate

Tek-Trol's Orifice Plates and Seals play a key role in maintaining the performance and durability of the orifice flow meters. Tek-Trol's orifice plates comply with AGA-3/API 14.3 or ISO 5167-1 standards to ensure maximum accuracy. The orifice plates are responsible for creating a restriction in the fluid's flow path which results in differential pressure. The differential pressure is then measured across the orifice plate, which can be found through two taps on the Single Chamber Orifice near the constriction. Types of orifice plates include conical, quadrant-edge, and square-edged entrant concentric, eccentric, and segmental orifice plates. Tek-Trol's orifice plates and seals are compatible with all Orifice Fitting variants; Single Chamber, Dual Chamber, and Orifice Flange Unions. The seals, crucial to maintain the leak-proof connections, are available for all plate sizes and types (soft seat valve seals, O-ring seals). All universal orifice plates are manufactured within the constraints of AGA3 (latest edition) and come with AGA3 compliant Orifice Inspection Plate reports.

The Universal Type Series provides orifice plates without a handle. They are manufactured for use in orifice plate holders such as Single Chamber and Dual Chamber Orifice Fittings. Tek-Trol's fail-safe concentric design of orifice plates eliminates the possibility of improper plate orientation and positioning.

Tek-Trol supplies orifice plates in standard 304SS and 316SS corrosion-resistant material and in a range of plate sizes from 1" to 48" to fulfil application needs. The orifice plates are also available in custom materials such as Duplex, Super Duplex, Monel, Inconel, and Hastelloy.

Features

- Leak-proof connection when used with seals.
- Separable seals for 8" and below.
- Special DVS bonded seals for 10" and above.

Technical Specifications

Size

1" to 48" (Larger line size available on customer request)

Material

SS304L, SS316L, Duplex, Super Duplex, Monel, Inconel, and Hastelloy (Other material available depending on requirements)

Bore

Concentric, Eccentric, and Quadrant

Surface Finish

Better than 25 micro inches as per AGA3

Universal Orifice Plates

Line Size (In)	Plate O.D.	Plate Thickness (In)
¾	1.125	1/8
1	1.312	1/8
1½	2	1/8
2	2.437	1/8
2½	2.812	1/8
3	3.437	1/8
4	4.406	1/8
6	6.437	1/8
8	8.437	¼
10	10.687	¼
12	12.593	¼
14	14	¼
16	16	3/8
18	18	3/8
20	20	3/8
24	24	½
26	26	½
30	30	½

Bonded Plates

Line Size (In)	Plate O.D.	Plate Thickness (In)
12	12.079	¼
14	14.563	¼
16	16.563	3/8
18	18.563	3/8
20	20.563	3/8
24	24.500	½
26	26.750	½
30	30.750	½
34	35.228	½
26	38	½
42	44	¾

Orifice Plate Sealing

DVS Dual Seal Line Sizes: 12 to 24 inch

In larger sizes, rubber is bonded directly to the outer edge of the orifice plate. If damaged, the DVS seal and plate may be returned to the factory for revulcanizing. Universal plates with bonded seal are Model 510.



Paddle-Type Plate

A range of specialized orifice plate bores are available to meet application requirements.

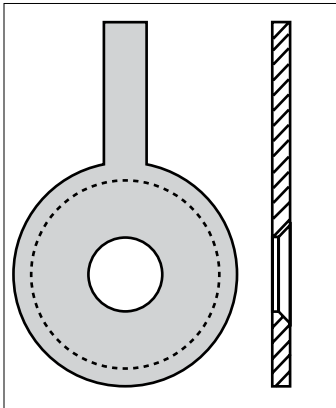

1610 E Bore and Bevel Concentric Orifice Plate

A range of specialized orifice plate bores is available to meet application requirements. The bore and bevel is the standard method of limiting the plate edge thickness. The bevel is machined on a 45° angle to the desired edge thickness. Unless otherwise specified the plates will be beveled to leave an edge thickness $1/50$ of the line ID or $1/8$ of the orifice bore, whichever is smaller.

1610 E Bore without Bevel (Concentric) Orifice Plate

For certain combinations of line size and plate thickness, it is not necessary to have a bevel to meet plate edge thickness requirements. In this case, the bore is drilled straight through the entire thickness of the plate. This bore is also used for bi-directional measurement and restriction orifices.

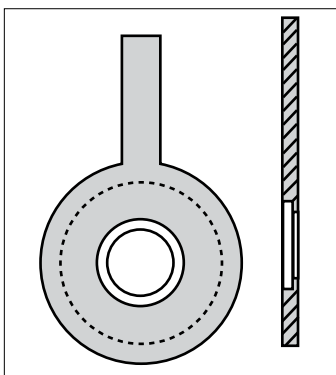
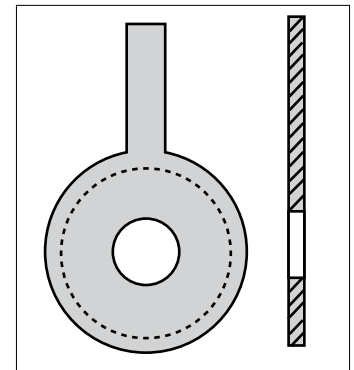

1610 E Bore and Counterbore Orifice Plate

The bore and counterbore is a special method to limit the plate edge thickness. Instead of bevelling at the normal 45° angle, the plate is counterbored to the desired edge thickness.

1610 E Segmental Bore Orifice Plate

Segmental bore orifice plates are provided for measurements to allow solids, liquids, and bubbles to pass through the bore. The circular portion of the bore is manufactured to be tangent to 98% of the pipe ID. Several industries use this type of bore, including sewage treatment, steel, chemical, water conditioning, paper and petrochemical.

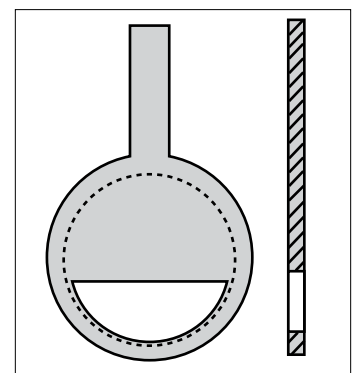

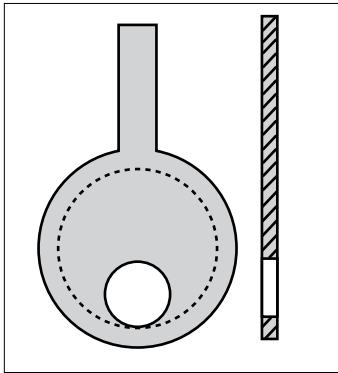

1610 E Eccentric Bore Orifice Plate

Eccentrically-bored plates position the bore off-centre as opposed to concentrically. The bore of the eccentric orifice is generally inscribed in a circle that is 98% of the pipe ID, enabling solids or slurries to pass through the bore. Eccentric orifice plates are used in many industries, including heavy and light chemicals, steel, paper, atomic and petrochemical.

1610 E Quarter Round Bore Orifice Plate

The quarter round, or quadrant bore, offers a rounded inlet edge. The radius of the quarter round bore is a function of the orifice-to-pipe ratio with thickness at the throat equal to the radius. Overall plate thickness is frequently greater than the thickness of standard plates. This bore is specifically designed for fluids of high viscosity, including heavy crudes, syrups and slurries. Quarter round bores are recommended for viscous fluids with Reynolds numbers below 10,000.

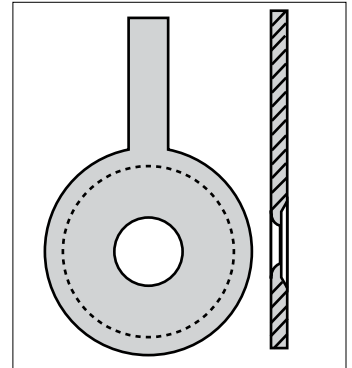

The Plate Dimension diagram corresponds to A, B, C, and D in Table given below All weights are based on the dimensions provided

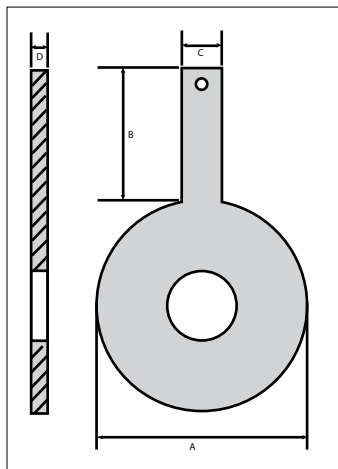

Hole Diameter by Plate Size (Metric Units)

Plate Size	Hole Diameter
DN15 to DN50	6.4mm
DN60 to DN600	9.5mm

Hole Diameter by Plate Size (US Customary Units)

Plate Size	Hole Diameter
0.5 in to 2 in	0.25 Inch
2.5 in to 24 in	0.375 inch

Weights and Dimensional Data (US Customary Units)

Line Size (DN)		0.50	0.75	1.00	1.25	1.50	2	2.5	3	4	6	8	10	12	14	16	18	20	24	
ANSI 150	Blank Weight (lb)	0.09	0.16	0.14	CF	0.43	0.59	CF	0.93	1.46	2.34	7.22	10.37	14.92	18.01	35.03	35.60	48.81	90.94	
	A:Plate OD (in)	1.875	2.25	2.265	3	3.375	4.125	4.875	5.375	6.87	8.75	11	13.37	16.12	17.75	20.25	21.5	23.75	28.125	
	B:Handle length (in)	4	4	4	4	4	6	6	6	6	6	6	6	6	6	6	6	6	6	6
	C:Handle with (in)	1	1	1	1	1	1	1.25	1.25	1.25	1.5	1.5	1.5	1.5	1.5	1.5	1.5	1.5	1.5	1.5
	D: Plate Thickness (in)	0.125	0.125	0.125	0.125	0.125	0.125	0.125	0.125	0.125	0.125	0.125	0.25	0.25	0.25	0.25	0.375	0.375	0.375	0.5
ANSI 300	Blank Weight (lb)	0.12	0.21	0.36	CF	0.52	0.66	CF	1.1	1.57	2.94	8.72	11.73	15.84	20.86	47.37	56.81	CF	106.12	
	A:Plate OD (in)	2.125	2.625	2.875	3.25	3.75	4.437	5.125	5.875	7.125	9.875	12.125	14.25	16.62	19.12	21.25	23.37	25.625	30.375	
	B:Handle length (in)	4	4	4	4	4	6	6	6	6	6	6	6	6	6	6	6	6	6	6
	C:Handle with (in)	1	1	1	1	1	1	1.25	1.25	1.25	1.5	1.5	1.5	1.5	1.5	1.5	1.5	1.5	1.5	1.5
	D: Plate Thickness (in)	0.125	0.125	0.125	0.125	0.125	0.125	0.125	0.125	0.125	0.125	0.125	0.25	0.25	0.25	0.25	0.375	0.375	0.375	0.5
ANSI 600	Blank Weight (lb)	0.12	0.21	0.36	CF	0.52	0.66	CF	1.1	1.78	3.33	9.46	14.25	18.52	21.4	42.18	49.95	61.88	110.52	
	A:Plate OD (in)	2.125	2.625	2.875	3.25	3.75	4.437	5.125	5.875	7.62	10.5	12.62	15.75	18	19.375	22.25	24	26.75	31	
	B:Handle length (in)	4	4	4	4	4	6	6	6	6	6	6	6	6	6	6	6	6	6	6
	C:Handle with (in)	1	1	1	1	1	1	1.25	1.25	1.25	1.5	1.5	1.5	1.5	1.5	1.5	1.5	1.5	1.5	1.5
	D: Plate Thickness (in)	0.125	0.125	0.125	0.125	0.125	0.125	0.125	0.125	0.125	0.125	0.125	0.25	0.25	0.25	0.25	0.375	0.375	0.375	0.5
ANSI 900	Blank Weight (lb)	0.12	0.21	0.42	CF	0.56	1.03	CF	1.37	2.01	3.87	11.78	16.79	21.95	23.92	43.61	54.2	64.86	125.2	
	A:Plate OD (in)	2.5	2.75	3.125	3.5	3.875	5.625	6.5	6.625	8.125	11.375	14.125	17.12	19.62	20.5	22.62	25	27.375	32.875	
	B:Handle length (in)	4	4	4	4	4	6	6	6	6	6	6	6	6	6	6	6	6	6	6
	C:Handle with (in)	1	1	1	1	1	1	1.25	1.25	1.25	1.5	1.5	1.5	1.5	1.5	1.5	1.5	1.5	1.5	1.5
	D: Plate Thickness (in)	0.125	0.125	0.125	0.125	0.125	0.125	0.125	0.125	0.125	0.125	0.125	0.25	0.25	0.25	0.25	0.375	0.375	0.375	0.5
ANSI 1500	Blank Weight (lb)	CF	CF	CF	CF	CF	CF	CF	CF	CF	CF	CF	CF	CF	CF	CF	CF	CF	CF	
	A:Plate OD (in)	2.5	2.75	3.125	3.5	3.875	5.625	6.5	6.875	8.25	11.125	13.875	17.12	19.62	22.75	25.25	27.625	29.625	35.5	
	B:Handle length (in)	4	4	4	4	4	6	6	6	6	6	6	6	6	6	6	6	6	6	6
	C:Handle with (in)	1	1	1	1	1	1	1.25	1.25	1.25	1.5	1.5	1.5	1.5	1.5	1.5	1.5	1.5	1.5	1.5
	D: Plate Thickness (in)	0.125	0.125	0.125	0.125	0.125	0.125	0.125	0.125	0.125	0.125	0.125	0.25	0.25	0.25	0.25	0.375	0.375	0.375	0.5
ANSI 2500	Blank Weight (lb)	CF	CF	CF	CF	CF	CF	CF	CF	CF	CF	CF	CF	CF	CF	CF	CF	CF	CF	
	A:Plate OD (in)	2.75	3	3.375	4.125	4.625	5.75	6.625	7.75	9.25	12.5	15.25	18.75	21.625	CF	CF	CF	CF	CF	
	B:Handle length (in)	4	4	4	4	4	6	6	6	6	6	6	6	6	6	6	6	6	6	6
	C:Handle with (in)	1	1	1	1	1	1	1.25	1.25	1.25	1.5	1.5	1.5	1.5	1.5	1.5	1.5	1.5	1.5	1.5
	D: Plate Thickness (in)	0.125	0.125	0.125	0.125	0.125	0.125	0.125	0.125	0.125	0.125	0.125	0.25	0.25	0.25	0.25	0.375	0.375	0.375	0.5

Ring-Type Joint (RTJ) Orifice Plate Holders

The 1610 E RTJ type Orifice Plate includes an internal gasket, either oval or octagonal ring, for mounting between ring-type joint flanges. It is based on proven technology, has no moving parts and is suitable for high temperature and pressure applications. These Orifice plates are suggested for clean liquids, gases, and low-velocity team flows



Dimensions of Ring-Type Joint (RTJ) Orifice Plate Holders

The thickness of the plate depends on line size and differential pressure. It should be thick enough to prevent the plate from bending under the operating conditions. The recommended plate thickness for flow measurement are shown below

Pipe Diameter	Standard Plate Thickness (mm) for Differential Pressure ΔP		
	$\Delta P = 250$ mbar	$\Delta P = 251 - 500$ mbar	$\Delta P = 501 - 2500$ mbar
$D \leq 150$ mm	3	3	3
$200 \leq D \leq 250$	3	3	6
$300 \leq D \leq 500$	6	6	10
$600 \leq D \leq 900$			
$\partial \leq 0.5$	10	10	12
$\partial \leq 0.5$	6	10	12

Materials for Ring-Type Joint (RTJ) Orifice Plate Holders

Tektrol's RTJ Orifice Plate Holders might be machined in one or two pieces with an orifice plate screwed onto the carrier ring/gasket. The Standard material grade for 1610E Orifice Plate includes 316 Stainless Steel, 304 Stainless Steel, 310 Stainless Steel, Hastelloy® C276, Hastelloy® B3, Duplex Stainless Steel, Super Duplex Stainless Steel, Monel® 400, Carbon Steel, Titanium, Incoloy® 800, Incoloy® 825, Inconel® 600 and Inconel® 625. The Common carrier ring/gasket materials comprise Stainless Steel and soft iron. To make sure correct sealing is installed between flanges, the hardness of the carrier ring/gasket material is limited to a maximum value, typically 120 for soft iron rings and 160 for Stainless Steel Rings.

Standard Plate and Ring Dimensions

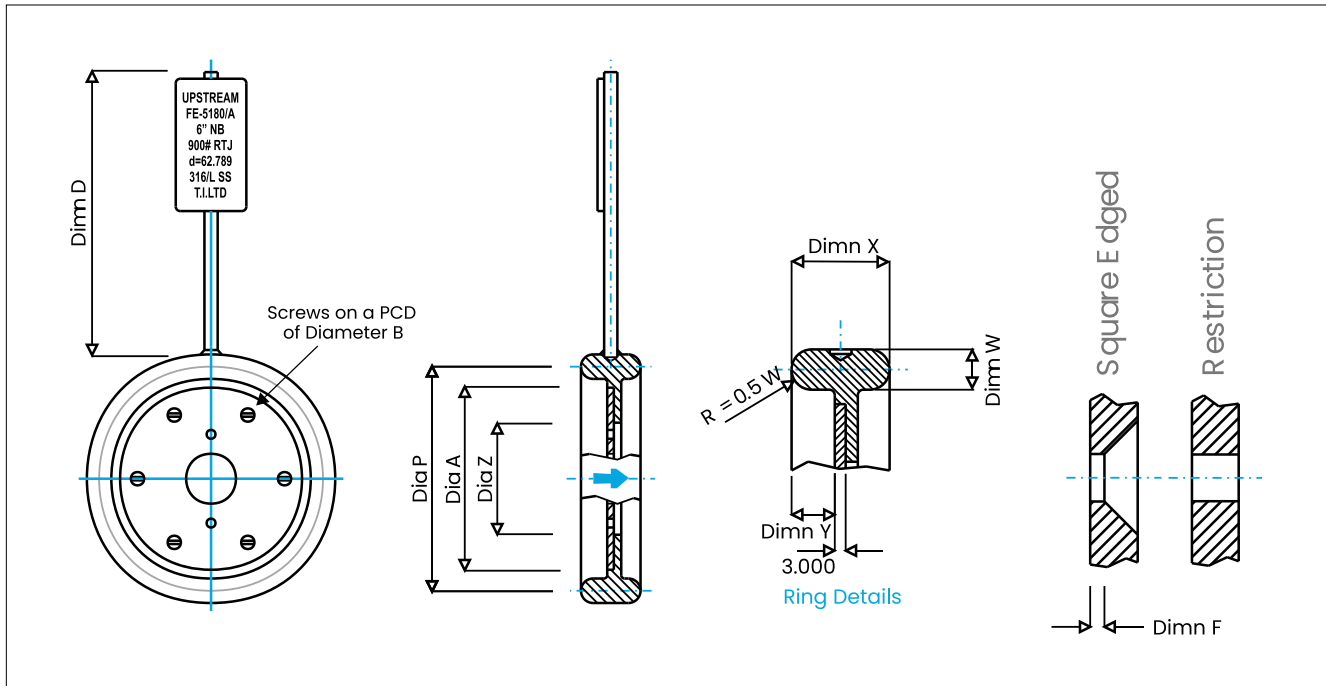

Dimensions of Ring-Type Joint (RTJ) Orifice Plate Holders

RATING AND LINE SIZE (INCHES)				RING No	DIA P	DIMN W	DIMN X	DIMN Y	DIA Z	DIMN F	DIA A	DIA B	DIMN D
300# 600#	900#	1500#	2500#										
1	1	1		R 16	50.8	7.9	23.8	10.3	25.4	0.5	41.3	33.3	125
			1	R 18	60.2	7.9	23.8	10.3	25.4	0.5	41.3	33.3	150
1.5	1.5	1.5		R 20	68.3	7.9	23.8	10.3	38.1	0.5	54	46	125
			1.5	R 23	82.5	11.1	27	10.3	38.1	0.5	54	46	150
2				R 23	82.5	11.1	27	11.9	50.8	0.75	69.8	60.3	125
	2	2		R 24	95.3	11.1	27	11.9	50.8	0.75	82.55	66.6	150
			2	R 26	101.6	11.1	27	11.9	50.8	0.75	82.55	66.6	150
2.5				R 26	101.6	11.1	27	11.9	63.5	0.75	85.5	69.5	125
	2.5	2.5		R 27	107.9	11.1	27	11.9	63.5	0.75	91.8	75.8	150
			2.5	R 28	111.1	12.7	27	11.9	63.5	0.75	93.4	77.4	150
3	3			R 31	123.8	11.1	27	11.9	76.2	1	107.9	92	150
			3	R 32	127	12.7	28.6	12.7	76.2	1	107.9	92	150
		3		R 35	136.5	11.1	27	11.9	76.2	1	107.9	92	150
4	4			R 37	149.2	11.1	27	11.9	104	1.5	136.5	120.6	150
			4	R 38	157.2	15.9	31.7	14.3	104	1.5	136.5	120.6	150
		4		R 39	162	11.1	27	11.9	104	1.5	136.5	120.6	150
6	6			R 45	211.1	11.1	27	11.9	158.7	1.5	190.5	174.6	150

		6		R 46	211.1	12.7	34.9	12.7	158.7	1.5	190.5	174.6	150
			6	R 47	228.6	19.1	27	15.9	158.7	1.5	190.5	174.6	175
8	8			R 49	269.9	11.1	27	11.9	209.5	3.5	241.3	225.4	175
		8		R 50	269.9	15.9	31.7	14.3	209.5	3.5	241.3	225.4	175
			8	R 51	279.4	22.2	38.1	17.5	209.5	3.5	241.3	225.4	175
10	10			R 53	323.8	11.1	27	11.9	260.3	3.5	292.1	276.2	175
		10		R 54	323.8	15.9	31.7	14.3	260.3	3.5	292.1	276.2	175
			10	R 55	342.9	28.6	46	21.4	260.3	3.5	292.1	276.2	200
12	12			R 57	381	11.1	27	11.9	311.2	3.5	342.9	327	175
		12		R 58	381	22.2	38.1	17.5	311.2	3.5	342.9	327	175
			12	R 60	406.4	31.7	49.2	23	311.2	3.5	342.9	327	200
14OD				R 61	419.1	11.1	27	11.9	343	5	374.6	358.8	150
	14OD			R 62	419.1	15.9	31.7	14.3	343	5	374.6	358.8	175
		14OD		R 63	419.1	25.4	27	19.8	343	5	374.6	358.8	175
16OD				R 65	469.9	11.1	27	11.9	393.7	5	425.4	409.6	150
	16OD			R 66	469.9	15.9	31.7	14.3	393.7	5	425.4	409.6	200
		16OD		R 67	469.9	28.6	46	21.4	393.7	5	425.4	409.6	200
18OD				R 69	533.4	11.1	27	11.9	444.5	5	476.2	460.4	175
	18OD			R 70	533.4	19.1	34.9	15.9	444.5	5	476.2	460.4	200
		18OD		R 71	533.4	28.6	46	21.4	444.5	5	476.2	460.4	200
20OD				R 73	584.2	12.7	28.6	12.7	495.3	8	517.5	501.6	175

Model Chart

Example	Tek-DP 1610E	U	50	A	1	01	XX	MTR	Tek-DP 1610E-U-50-A-1-50-XX-MTR
Series	Tek-DP 1610E								Orifice Plate
Type		U P RTJ							Universal Paddle Paddle (RTJ)
Size			50 65 80 100 150 200 250 300 650 700 750 800 850						2" 2 1/2" 3" 4" 6" 8" 10" 12" 14" 16" 18" 20" XXX- Special
Material Construction				A X					316LSS / 316SS Special
Pipe Schedule					57D 40 60 80 XS XX				STD 40 60 80 XS Special
Thickness (inches)						01 02 03 04 XX			1/8" 1/4" 3/8" 1/2" Special
Beta							XX		Special
Options								MTR MC PMI COC TAG CDE MRB CPC AGA3 CMM	Material Test Report EN3.1 Material Cert EN2.1 Positive Material Identification (NDE) Certificate of Conformity SS Tag Plate Certified Drawing Electronic (As Built) Manufacturing Record Book Custom Product Code Orifice plate inspection report CMM reports

Customer Service & Support



TEK-TROL LLC reserves the right to change the designs and/or materials of its products without notice. The contents of this publication are the property of TEK-TROL LLC and cannot be reproduced by any other party without written permission. All rights reserved. Copyright © 2020 TEK-TROL LLC
DOC # TEK/ITP-5/CAT/241806/1610E/00
TEK-TROL LLC





www.tek-trol.com

Tek-Trol LLC

796 Tek Drive Crystal Lake,
IL 60014, USA

 +1 847-857-6076

 tektrol@tek-trol.com

 www.tek-trol.com

Tek-Trol is a fully owned subsidiary of TEKMATIION LLC. We offer our customers a comprehensive range of products and solutions for process, power and oil & gas industries. Tek-Trol provides process measurement and control products for Flow, Level, Temperature & Pressure measurement, Control valves & Analyzer systems. We are present in 15 locations globally and are known for our knowledge, innovative solutions, reliable products and global presence.