

Tek-Vor 1300XP ***INLINE VORTEX FLOW METER***



Quick Start Guide

1. Before You Begin

This guide provides basic guidelines to assist you in quickly getting started.



Installation of the transmitter in an explosive environment must be in accordance with the appropriate local, national, and international standards, codes, and practices. Review the approvals section of the Tek-Vor 1300XP reference manual for any restrictions associated with a safe installation.



Make sure the transmitter is installed by qualified personnel and in accordance with applicable codes of practice.



Do not remove the transmitter covers in explosive environments when the circuit is live.

2. Unpack

Tek-Vor 1300XP In-Line Vortex Flow Meter

3. Dimensional Drawing

Tek-Vor 1300XP Inline Flanged Models

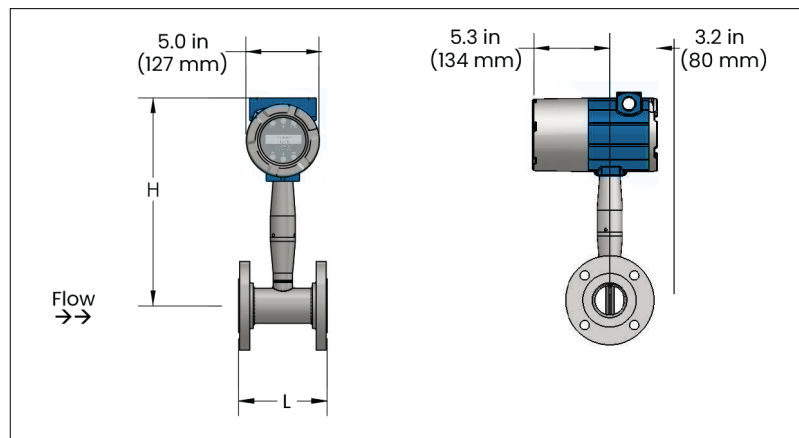

Flow Meter Nominal Size	L	L (ANSI 900)	H	Weight			
				ANSI 150 (PN 16)	ANSI 300 (PN 40)	ANSI 600 (PN 63)	ANSI 900 (PN 160)
1/2" (15mm)	7.9" (200 mm)	7.9" (201 mm)	13.5" (343 mm)	12 Lb (5.5 kg)	12.5 Lb (5.7 kg)	13.4 Lb (6.1 kg)	17.6 Lb (8 kg)
3/4" (20 mm)	7.9" (200 mm)	9.7" (247 mm)	13.5" (343 mm)	13 Lb (5.9 kg)	14.6 Lb (6.6 kg)	15.6 Lb (7.1 kg)	21.0 Lb (9.5 kg)
1" (25 mm)	7.9" (200 mm)	10.8" (274 mm)	13.5" (343 mm)	13.5 Lb (6.1 kg)	16.3 Lb (7.4 kg)	16.4 Lb (7.5 kg)	26.3 Lb (11.9 kg)
1.5" (40 mm)	7.9" (200 mm)	12.0" (305 mm)	13.8" (351 mm)	16.3 Lb (7.4 kg)	23.3 Lb (10.6 kg)	24.6 Lb (11.2 kg)	37.2 Lb (16.9 kg)
2" (50 mm)	7.9" (200 mm)	14.1" (357 mm)	14.0" (356 mm)	21.2 Lb (9.6 kg)	26.8 Lb (12.2 kg)	33.2 Lb (15.1 kg)	60.5 Lb (27.4 kg)

3" (80 mm)	7.9" (200 mm)	14.8" (375 mm)	14.6" (371 mm)	33 Lb (15 kg)	41.0 Lb (16.6 kg)	56.1 Lb (25.5 kg)	76.5 Lb (34.7 kg)
4" (100 mm)	9.84" (250 mm)	16.9" (429 mm)	15.1" (384 mm)	45.8 Lb (20.8 kg)	66.8 Lb (30.3 kg)	96.0 Lb (43.6 kg)	121.2 Lb (55 kg)
6" (150 mm)	11.81" (300 mm)	19.5" (495 mm)	16.2" (411 mm)	68.3 Lb (31.0 kg)	106.3 Lb (48.2 kg)	194.3 Lb (88.2 kg)	254.4 Lb (115.4 kg)
8" (200 mm)	11.81" (300 mm)	22.8" (579 mm)	17.2" (437 mm)	112.4 Lb (51.0 kg)	168.4 Lb (76.5 kg)	299.0 Lb (136 kg)	433.0 Lb (196.4 kg)
10" (250 mm)	15" (381 mm)	29.0" (737 mm)	18.2" (462 mm)	188.3 Lb (85.5 kg)	262.3 Lb (119.1 kg)	462.3 Lb (209.9 kg)	665.9 Lb (302.0 kg)
12" (250 mm)	17.7" (450 mm)	30.3" (770 mm)	19.2" (488 mm)	298.6 Lb (135.6 kg)	402.6 Lb (182.8 kg)	606.6 Lb (275.4 kg)	926.6 Lb (420.3 kg)

Add 11 lb (5 kg) for remote electronics

Tek-Vor 1300XP Inline Reduced Bore Flanged Models

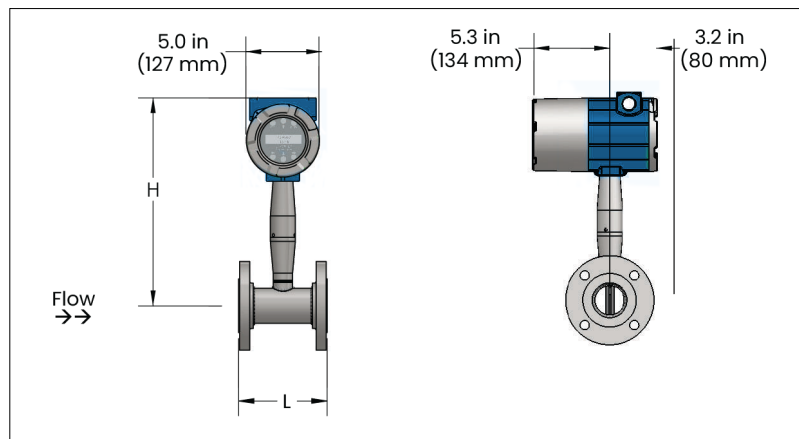

Flow Meter Nominal Size	L	L (ANSI 900)	H	Weight			
				ANSI 150 (PN 16)	ANSI 300 (PN 40)	ANSI 600 (PN 63)	ANSI 900 (PN 160)
3/4" (20 mm) X 1/2" (15 mm)	7.9" (200 mm)	8.4" (213 mm)	13.5" (343 mm)	13 Lb (5.9 kg)	14.6 Lb (6.6 kg)	15.6 Lb (7.1 kg)	20.6 Lb (9.3 kg)
1" (25 mm) X 1/2" (15 mm)	7.9" (200 mm)	8.4" (213 mm)	13.5" (343 mm)	13 Lb (5.9 kg)	16.3 Lb (7.4 kg)	16.4 Lb (7.5 kg)	22.7 Lb (10.3 kg)
1.5" (40 mm) X 1" (25 mm)	7.9" (200 mm)	11.1" (282 mm)	13.8" (351 mm)	13.4 Lb (6.1 kg)	23.3 Lb (10.6 kg)	24.6 Lb (11.2 kg)	36.3 Lb (16.5 kg)
2" (50 mm) X 1-1/2" (40 mm)	7.9" (200 mm)	12.5" (318 mm)	14.0" (356 mm)	16.3 Lb (7.4 kg)	26.8 Lb (12.2 kg)	33.2 Lb (15.1 kg)	58.1 Lb (26.4 kg)
3" (80 mm) X 2" (50 mm)	7.9" (200 mm)	14.1" (357 mm)	14.6" (371 mm)	21.2 Lb (9.6 kg)	41.0 Lb (18.6 kg)	56.1 Lb (25.5 kg)	73.7 Lb (33.4 kg)

Quick Start Guide

4" (100 mm) X 3" (80 mm)	9.84" (250 mm)	15.3" (389 mm)	15.1" (384 mm)	33 Lb (15 kg)	66.8 Lb (30.3 kg)	96.0 Lb (43.6 kg)	116.1 Lb (52.7 kg)
6" (150 mm) X 4" (100 mm)	11.81" (300 mm)	17.8" (452 mm)	16.2" (411 mm)	45.8 Lb (20.8 kg)	106.3 Lb (48.2 kg)	194.3 Lb (136 kg)	220.5 Lb (100.0 kg)
8" (200 mm) X 6" (150 mm)	11.81" (300 mm)	20.1" (511 mm)	17.2" (437 mm)	68.3 Lb (31.0 kg)	168.4 Lb (76.5 kg)	299.0 Lb (88.2 kg)	365.7 Lb (165.9 kg)
10" (250 mm) X 8" (200 mm)	15.0" (381 mm)	23.3" (592 mm)	18.2" (462 mm)	188.3 Lb (85.5 kg)	262.3 Lb (119.1 kg)	462.3 Lb (209.9kg)	562.8 Lb (255.3 kg)
12" (300 mm) X 10" (250 mm)	17.7" (450 mm)	29.7" (754 mm)	19.2" (488 mm)	298.6 Lb (135.6 kg)	402.6 Lb (182.8 kg)	606.6 Lb (275.4 kg)	792.3 Lb (359.4 kg)

Add 11 lb (5 KG) for remote electronics

Tek-Vor I300XP Inline Water Models

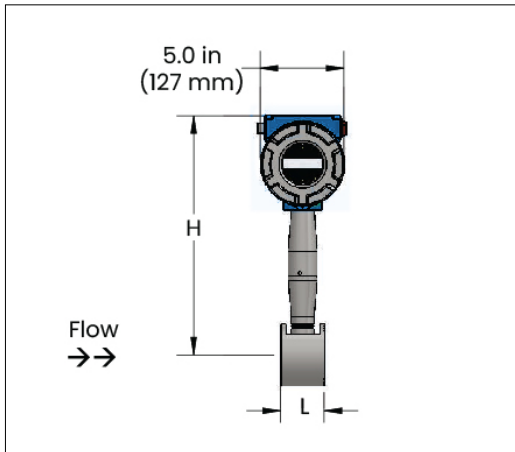

Flow Meter Nominal Size	L	H	Diameter	Approximate Weight
1/2" (15mm)	2.56" (65 mm)	13.5" (343 mm)	1.38" (35 mm)	9.2 Lb (4.2 kg)
3/4" (20 mm)	2.56" (65 mm)	13.5" (343 mm)	1.69" (43 mm)	9.5 Lb (4.3 kg)
1" (25 mm)	2.56" (65 mm)	13.5" (343 mm)	2.0" (51 mm)	10.3 Lb (4.7 kg)
1-1/2" (40 mm)	2.56" (65 mm)	13.8" (351 mm)	2.88" (73 mm)	12.1 Lb (5.5 kg)
2" (50 mm)	2.56" (65 mm)	14.0" (356 mm)	3.62" (92 mm)	14.1 Lb (6.4 kg)
3" (80 mm)	2.56" (65 mm)	14.6" (371 mm)	5.0" (127 mm)	18.7 Lb (8.5 kg)
4" (100 mm)	2.56" (65 mm)	15.1" (384 mm)	6.19" (157 mm)	23.4 Lb (10.6 kg)

Add 11 lb (5 KG) for remote electronics

Tek-Vor I300XP Inline Reduced Bore Wafer Models

Flow Meter Nominal Size	L	H	Diameter	Approximate Weight
3/4" (15mm) X 1/2" (15mm)	2.56" (65 mm)	13.5" (343 mm)	1.38" (35 mm)	9.2 Lb (4.2 kg)
1" (25 mm) X 3/4" (20 mm)	2.56" (65 mm)	13.5" (343 mm)	1.69" (43 mm)	9.50 Lb (4.3 kg)
1-1/2" (40 mm) X 1" (25 mm)	2.56" (65 mm)	13.8" (351 mm)	2.0" (51 mm)	10.3 Lb (4.7 kg)
2" (50 mm) X 1-1/2" (40 mm)	2.56" (65 mm)	13.8" (351 mm)	2.88" (73 mm)	12.1 Lb (5.5 kg)
3" (80 mm) X 2" (50 mm)	3.94" (100 mm)	14.6" (371 mm)	5.0" (127 mm)	23.9 Lb (8.5 kg)
4" (100 mm) X 3" (80 mm)	4.72" (120 mm)	15.1" (384 mm)	6.19" (157 mm)	35.2 Lb (10.6 kg)

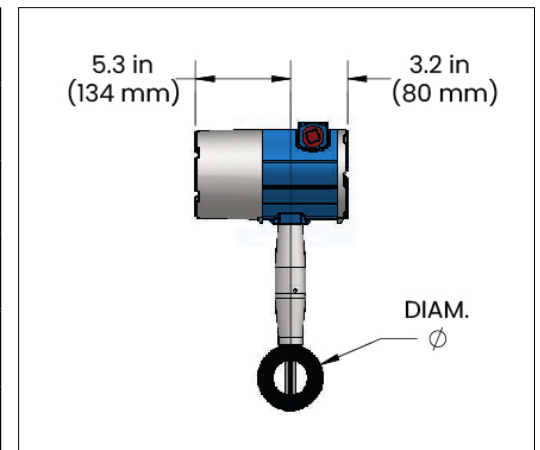

Add 11 lb (5 KG) for remote electronics

Remote Electronics Option

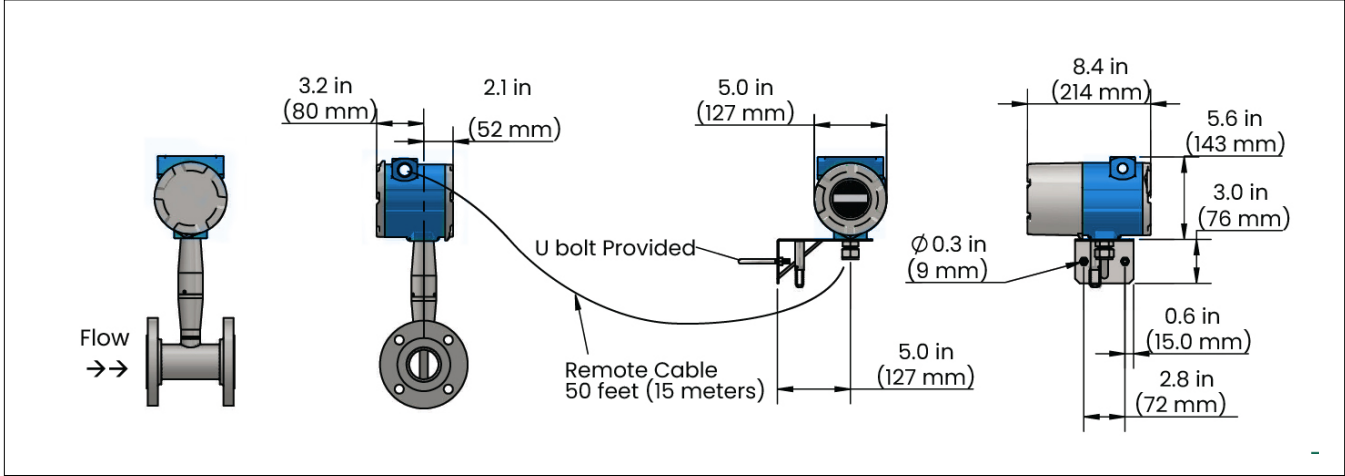

4. Power Supply

4–20 mA and Pulse Wiring

For a 4–20 mA and Pulse configuration, the flow meter typically uses a 12–36 VDC supply (24 VDC nominal) for the current loop. Connect the power supply “+” to the meter’s 4–20 mA “+” terminal and the meter’s 4–20 mA “-” terminal back to the supply “-” (or through your controller/PLC in series), ensuring correct polarity and enough voltage to account for loop resistance. The pulse output is usually an open-collector transistor that requires an external pull-up resistor (to 5–24 V) if not provided by the receiving device; always observe the maximum voltage/current ratings on the pulse terminals.

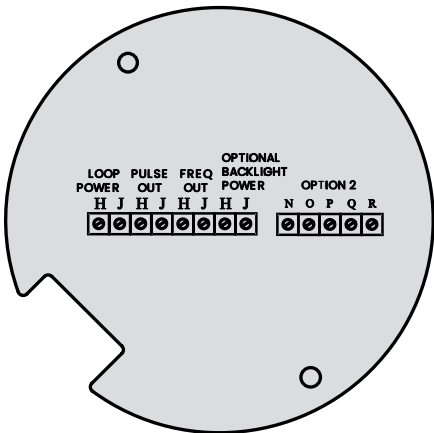

Fig. 1 Loop Power Wiring Terminals

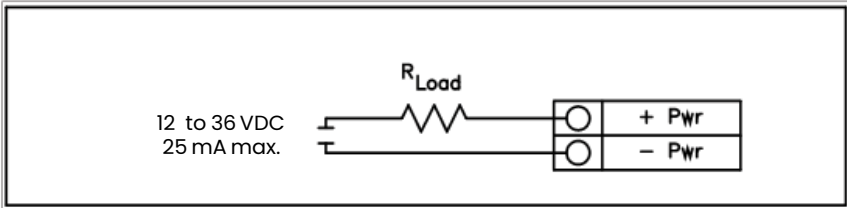

Fig. 2 DC Power Connections

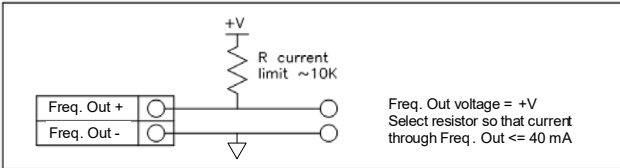

Fig. 3 Isolated Frequency Output using External Power Supply

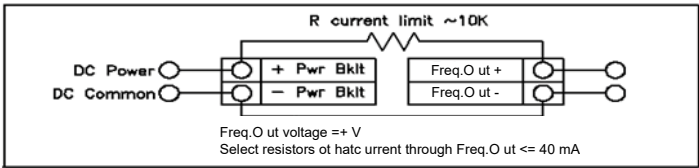

Fig. 4 Non-Isolated Frequency Output using External Power Supply

Quick Start Guide

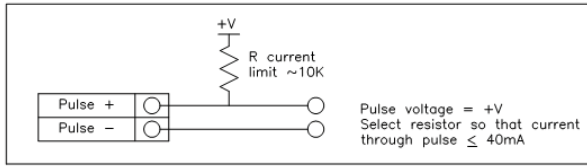

Fig. 4 Isolated Pulse Output using External Power Supply

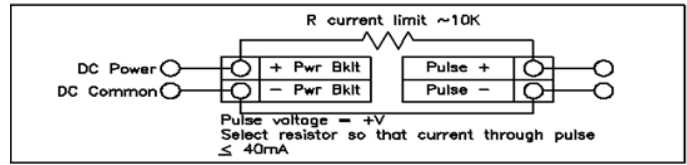

Fig. 5 Non-Isolated Pulse Output using External Power Supply

HART wiring

For a 4–20 mA, Pulse, and HART configuration, the Tek-Vor 1300 XP still uses the same two-wire loop as standard 4–20 mA, with the addition of a 250 Ω resistor in series if your control system input impedance is below 250 Ω (to enable HART communication). The HART communicator can attach across this resistor or at the transmitter terminals, so long as there is enough supply voltage to power both the meter and communicator. Meanwhile, the pulse output follows the same open-collector wiring described previously: it requires an external pull-up resistor to a suitable voltage source if your receiving device does not provide one.

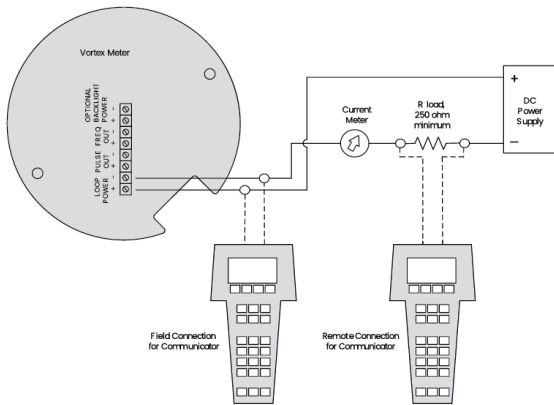

Fig. 6 Loop Powered Meter Wiring (HART)

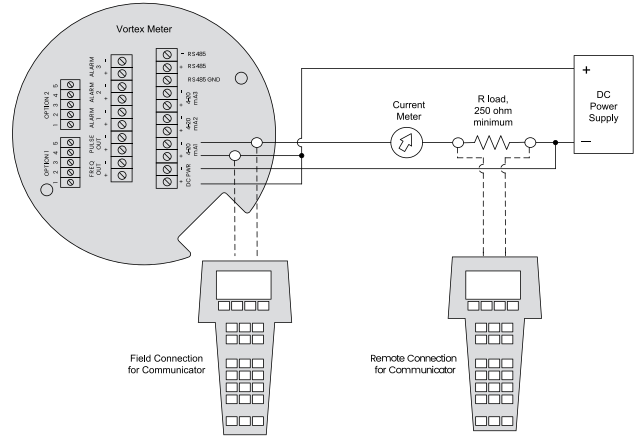

Fig. 7 DC Powered Meter Wiring (HART)

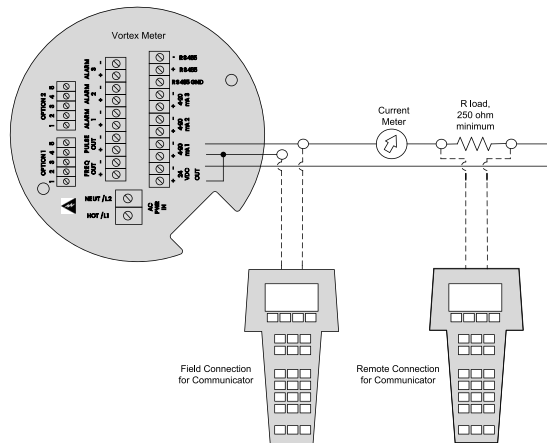

Fig. 8 AC Powered Meter Wiring (HART)

RS485 (Modbus) Wiring

The Tek-Vor 1300XP RS485 communication requires connecting each device's "A" (or "D+") terminals together and each "B" (or "D-") terminals together in a multi-drop bus configuration. A shield or ground reference should be tied to earth at one end to help minimize noise. In many installations, a 120 Ω termination resistor is placed across A and B at each end of the bus to reduce signal reflections and ensure stable communication.

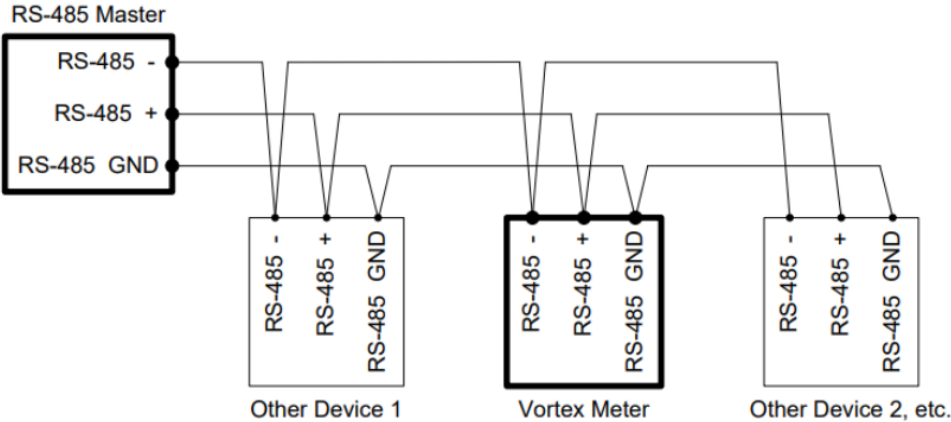

Fig. 9 RS485 (Modbus) Wiring

Ethernet / TCP-IP (PoE) Wiring

For Ethernet/TCP-IP (PoE) Wiring, connect the LAN terminal to a PoE switch or injector for both power and data transmission over a single Ethernet cable. If PoE is not available, use the DC PWR terminals as an alternative power source, ensuring wire sizes between 20–12 AWG with a 7 mm strip length. When installing in NEMA 4X enclosures, use certified conduit fittings for environmental protection, and seal unused entries with approved blanking elements. For hazardous area installations, ensure flameproof conduit seals are installed within 18 inches (457 mm) of the enclosure.

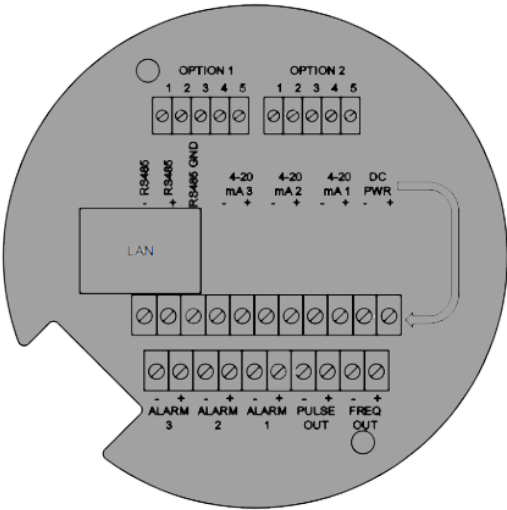

Fig. 10 POE Wiring Terminals

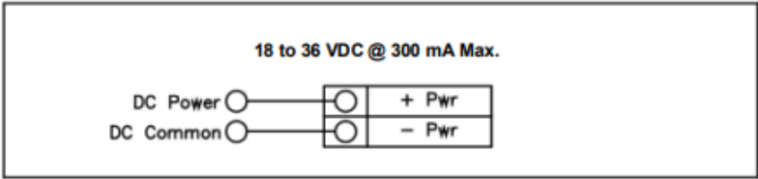
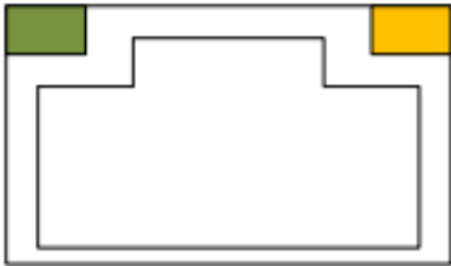

Fig. 11 DC Power Connections



Quick Start Guide

- Before doing wiring work, turn OFF the power supply to prevent electric shocks.
- Connect a power source with the correct rating to prevent an accident
- Ensure installation of the transmitter meets applicable state and national electrical code requirements. Do not remove the transmitter covers in explosive environments when the circuit is live. Both transmitter covers must be fully engaged to meet explosion-proof requirements.

Note: For more information on Power Supply, refer to the detailed manual.

5. Grounding

The power supply of signal processing circuit in Tek-Vor 1300XP IN Line Vortex Flow Meter is transferred from an outside power supply by an isolation type DC-to-DC transmitter with advanced grounding technology. The field frequency interference can be isolated well.

When using this product, the “V-” of power supply should not be connected with the ground. When this product is used in an environment with strong interference, the shell should be in connection with the earth through a cable, so the interference can be eliminated.

Note: Make sure that the flow meter is properly grounded.

6. Communication

- **The communication interface for a Tek-Vor 1300XP** should support **HART, Modbus RTU (RS485), and BACnet MS/TP**, enabling seamless data exchange in industrial environments.
- **The wiring terminals for RS485 communication** are labeled “A” (D+) and “B” (D-). For power wiring details, refer to **Section 4 (Power Supply)** of this Quick Start Guide.
- **For HART communication**, a **250 Ω load resistor** is required in the **4–20 mA loop** to enable proper signal transmission and diagnostics.
- **For Modbus RTU and BACnet MS/TP (RS485)**, connect all devices in a **parallel daisy-chain**, use **120 Ω termination resistors** at both ends, and ground the shield at one end only. Ensure **matching baud rate, parity, and stop bits** across all devices for stable communication.

Note: For more information on communication, refer to the detailed manual.

7. Configuration

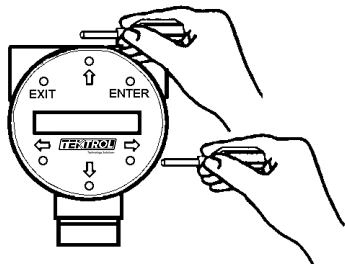

The Tek-Vor 1300XP flow meter is equipped with digital electronics that allow users to set, adjust, and monitor system parameters and performance. A comprehensive range of commands is accessible through the integrated display and keypad. The LCD display, featuring 2 x 16 characters, facilitates both flow monitoring and programming.

The configuration of the Tek-Vor 1300XP can be done using six pushbuttons. Like A black triangle with two arrows. \updownarrow The Up-Down Button, A black and white arrow \leftrightarrow and L-R buttons these buttons can be operated with the enclosure cover removed for direct access. Alternatively, if the explosion-proof cover remains in place, users can operate the keypad using a hand-held magnet positioned at the side of the enclosure, as illustrated in the diagram

Below are the available keypad commands for configuring the device:

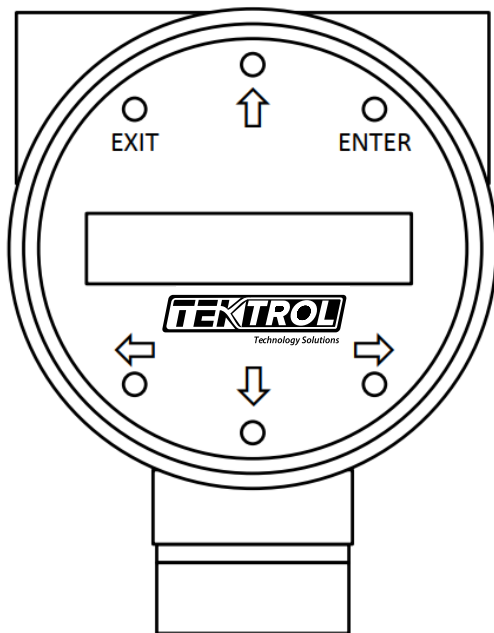

1. Run Mode: the ENTER key allows access to the Setup Menus (through a password screen). Within the Setup Menus, pressing ENTER activates the current field.
2. Set Up Menu, press the ENTER key until an underline cursor appears. Use the \uparrow \downarrow \leftarrow \rightarrow keys to select new parameters. Press ENTER to continue. (If change is not allowed, ENTER has no effect.) All outputs are disabled when using the Setup Menus. The EXIT key is active within the Setup Menus. When using a Setup Menu, EXIT returns you to the Run Mode. If you are changing a parameter and make a mistake, EXIT allows you to start over.
3. The \uparrow \downarrow \leftarrow \rightarrow keys advance through each screen of the current menu. When changing a system parameter, all \uparrow \downarrow \leftarrow \rightarrow keys are available to enter new parameters.

Fig. 12 Flow Meter Display/Keypad

8. Flow Direction

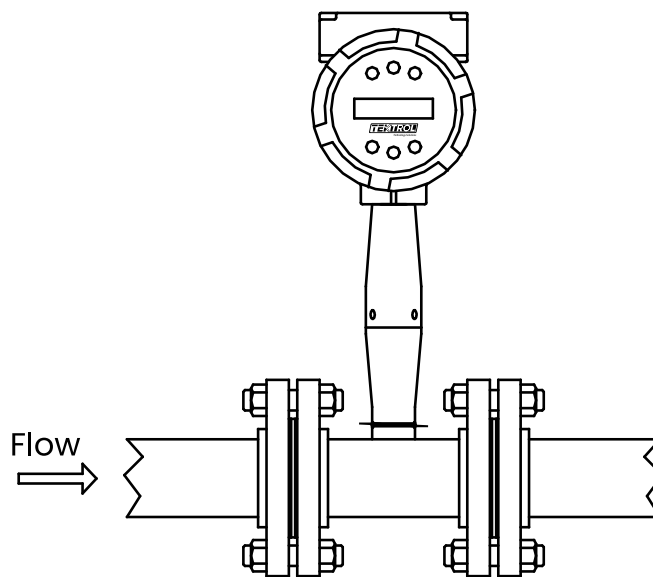

Quick Start Guide

9. Installation

Liquid Horizontal

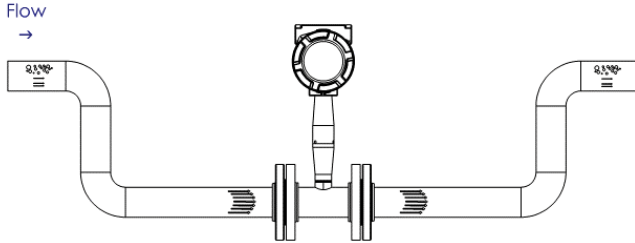

Liquid Vertical

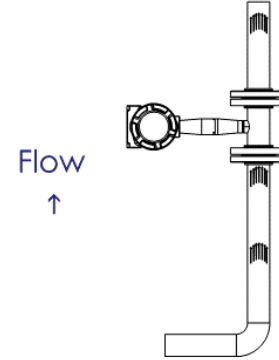

Gas/Steam Horizontal

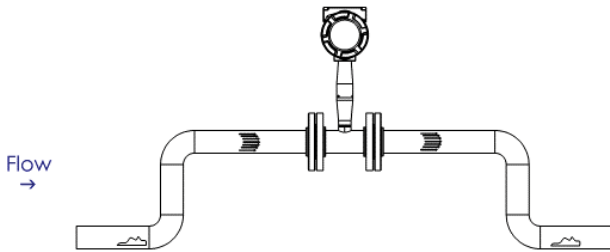

Gas/Steam Vertical

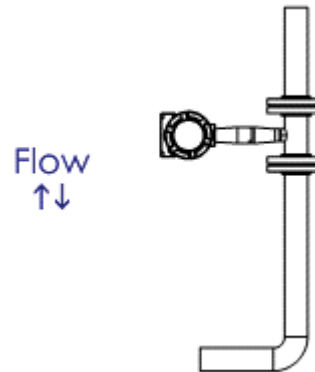

Note: For information on Installation, refer to the detailed manual.

10. Error Messages

Note: For information on error messages, refer to the detailed manual.



Technology Solutions

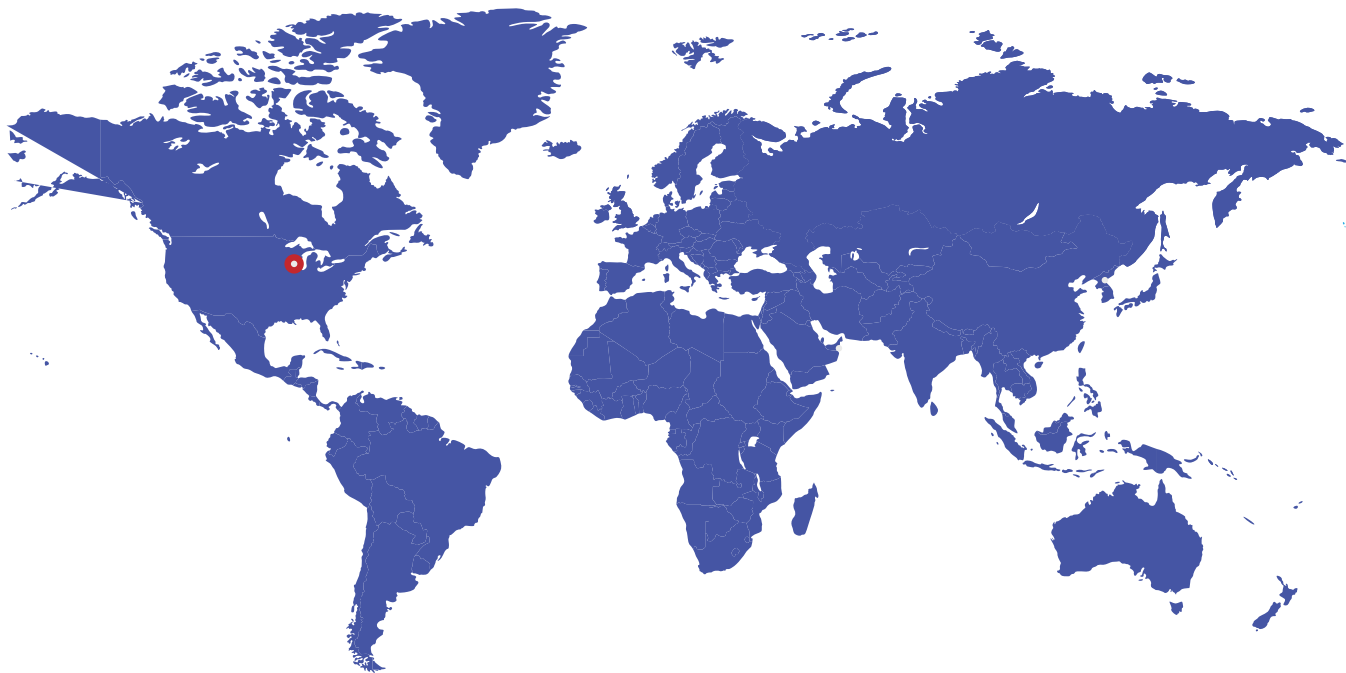

796 Tek Drive
Crystal Lake, IL 60014
USA

Tel: +1 847 857 6076

Fax: +1 847 655 6147

Email: tektrol@tek-trol.com

www.tek-trol.com

Tek-Vor 1300XP